



HP Latex R530 Printer Series User Guide

SUMMARY

How to use your product.

About this edition

Edition 2, November 2025

© Copyright 2025 HP Development Company, L.P.

Legal notices

The information contained herein is subject to change without notice.

The only warranties for HP products and services are set forth in the express warranty statements accompanying such products and services. Nothing herein should be construed as constituting an additional warranty. HP shall not be liable for technical or editorial errors or omissions contained herein.

Trademarks

Microsoft® and Windows® are U.S. registered trademarks of Microsoft Corporation.

Table of contents

| | |
|--------------------------------------------------------------------|-----------|
| 1 Introduction | 1 |
| Welcome to your printer | 1 |
| Documentation and useful links | 1 |
| Safety precautions | 3 |
| Main printer components | 10 |
| Printer software | 14 |
| HP PrintOS | 14 |
| Connectivity and job submission | 15 |
| Turn the printer on and off | 18 |
| Restart the printer | 20 |
| 2 HP Internal Print Server | 21 |
| Start the Internal Print Server | 21 |
| Internal Print Server widgets | 22 |
| Printer status and alerts | 23 |
| Update the printer's firmware and software (Internal Print Server) | 23 |
| Internal Print Server settings and preferences | 27 |
| Printer diagnostics | 27 |
| 3 Handle the substrate | 39 |
| Overview | 39 |
| Supported substrate categories | 39 |
| Supported HP substrates | 39 |
| How to store and handle substrate | 42 |
| Load rigid substrate | 42 |
| How to load rigid media with special register requirements | 50 |
| Load a roll into the printer with buttons | 55 |
| Take-up reel | 58 |
| Unload a roll from the printer | 62 |
| Hold-down plate | 65 |
| Maintenance tasks | 67 |
| Substrate tips | 74 |
| Substrate configuration | 76 |
| How to print (overview) | 79 |
| 4 Substrate settings | 80 |

| | |
|---------------------------------------------------------------------|------------|
| Substrate presets..... | 80 |
| Generic presets..... | 80 |
| Use a new substrate..... | 81 |
| Prepare the printer for a new substrate..... | 81 |
| Add a substrate preset..... | 81 |
| Expert mode..... | 86 |
| Online search - HP Media Locator..... | 87 |
| Select the number of passes..... | 88 |
| Recommendations for optimal color calibration..... | 89 |
| 5 Create and manage print jobs..... | 91 |
| Add a new print job..... | 91 |
| Job properties..... | 92 |
| 6 Handle the ink system..... | 94 |
| Ink system components..... | 94 |
| Printing with white ink..... | 115 |
| 7 Printer calibration..... | 126 |
| Align the printheads..... | 126 |
| Color calibration..... | 127 |
| ICC profiles..... | 130 |
| Recommended calibrations after particular events..... | 130 |
| Color consistency between different HP Latex R series printers..... | 130 |
| 8 Printer maintenance..... | 131 |
| General cleaning instructions..... | 131 |
| Maintenance tools recommended but not provided..... | 131 |
| Check and clean the printheads..... | 132 |
| Clean the electrical connections on a printhead..... | 132 |
| Clean and lubricate the printhead carriage rod..... | 139 |
| Clean the encoder strip..... | 139 |
| Replace the rod oiler and felts..... | 140 |
| Replace or empty the condensation collector..... | 141 |
| Check and clean the plastic needles in the printhead slot..... | 142 |
| Replace the plastic needles in the printhead slot..... | 144 |
| Clean the exterior of the printer..... | 146 |
| Curing user maintenance..... | 146 |
| Clean the curing modules..... | 148 |
| Service maintenance..... | 148 |

| | |
|------------------------------------------------------------------------|------------|
| 9 Software updates | 150 |
| Automatic firmware and software updates | 150 |
| Manual firmware and software updates | 151 |
| 10 Troubleshoot substrate issues | 156 |
| Loading issues..... | 156 |
| The substrate cannot be measured successfully..... | 158 |
| Print from pinch for flexible media | 158 |
| Flexible substrate print-length troubleshooting | 158 |
| Substrate has bow deformation..... | 159 |
| Rigid substrate registration troubleshooting..... | 160 |
| 11 Printing issues | 166 |
| There are physical marks on the substrate | 166 |
| Rigid substrate too close to the carriage bottom..... | 167 |
| There are wrinkles and ink smears on the substrate | 167 |
| Media advance issues | 169 |
| The substrate advances with a loud continuous sound of vibration | 169 |
| There is skew or telescoping on the output roll rewinder | 169 |
| There are ink marks on the substrate | 170 |
| 12 Troubleshoot print-quality issues | 171 |
| General printing advice..... | 171 |
| Improve print quality | 172 |
| Most-common print-quality problems | 177 |
| 13 Troubleshoot ink-system issues | 194 |
| Cannot insert an ink cartridge | 194 |
| Installation of an unshaken cartridge | 194 |
| Control panel recommends reseating or replacing a printhead..... | 196 |
| Cannot insert a printhead | 196 |
| Cannot insert the maintenance cartridge | 196 |
| 14 Troubleshoot other issues | 198 |
| The printer does not start..... | 198 |
| The printer cannot be restarted from the Internal Print Server..... | 198 |
| The Internal Print Server cannot detect the printer | 198 |
| Printer is not printing..... | 198 |
| Printer seems slow | 199 |
| Communication failures between computer and printer..... | 200 |
| System error codes | 200 |

| | |
|--------------------------------------------------------------------------|------------|
| Program slows down or stalls while generating the print job..... | 202 |
| 15 Customer Self-Repair parts..... | 203 |
| List of Customer Self-Repair parts | 203 |
| Where to find instructions for replacing Customer Self-Repair parts..... | 203 |
| 16 Supplies and accessories..... | 210 |
| Printer accessories and consumables | 210 |
| Disposal instructions..... | 210 |
| Accessories..... | 211 |
| 17 Move or store the printer | 216 |
| Move the printer to a location on the same floor | 216 |
| Preparing the ink supply tray..... | 217 |
| Move the printer over obstacles or with special transportation | 219 |
| Store the printer..... | 219 |
| Storage outside environmental specifications | 219 |
| 18 Printer specifications..... | 220 |
| Functional specifications | 220 |
| Physical specifications..... | 222 |
| Memory specifications | 222 |
| Power specifications..... | 222 |
| Ecological specifications..... | 223 |
| Environmental specifications | 223 |
| Acoustic specifications | 223 |
| Appendix A Summary of common printing problems..... | 224 |
| Appendix B Rigid substrate recommendations..... | 226 |
| Corrugated plastic..... | 226 |
| Paper foamboard..... | 227 |
| PVC foam | 228 |
| PVC foam | 228 |
| ACP..... | 229 |
| Solid plastic..... | 230 |
| Uncoated cardstock..... | 232 |
| Recommended print modes (introduction)..... | 234 |
| Use Sensitive Mode with heat-sensitive substrates..... | 234 |
| Predefined substrate settings | 234 |
| Acrylic sheet (PMMA)..... | 235 |
| Aluminum composite panel (ACP) | 237 |

| | |
|------------------------------------------------------------|------------|
| Compressed cardboard or cardstock..... | 238 |
| Corrugated cardboard | 239 |
| Foam board | 240 |
| Foam PVC | 241 |
| Glass and ceramics | 242 |
| Wood | 243 |
| Polycarbonate sheet | 243 |
| Polystyrene sheet..... | 244 |
| Polypropylene sheet | 245 |
| PVC rigid sheet (U-PVC)..... | 245 |
| PET (A-PET, PET-G) rigid sheet | 246 |
| PE (LDPE, HDPE) rigid sheet..... | 247 |
| Honeycomb panels..... | 248 |
| Metal panels | 248 |
| Appendix C Flexible substrate recommendations | 250 |
| Predefined substrate settings | 250 |
| Self-adhesive vinyls | 250 |
| Banners..... | 251 |
| Paper | 252 |
| PVC banners..... | 253 |
| Papers..... | 253 |
| Textiles | 254 |
| Flexible films | 255 |
| Index..... | 256 |

1 Introduction

An introduction to your product.

Welcome to your printer

Your printer is a color inkjet printer designed for printing high-quality images on flexible and rigid substrates.

Some major features of the printer are shown below:

- Environmentally friendly, odorless, aqueous latex inks in eight colors plus optimizer.
- No special ventilation required, no hazardous waste.
- Nine 3-liter Eco-Carton ink cartridges, one for each color (black, cyan, magenta, yellow, light cyan, light magenta, optimizer, overcoat and white).
- Consistent and repeatable print quality at every print speed.
- Prints are completely dry and ready for finishing and delivery.
- Print on a wide range of substrates, including most low-cost, uncoated, solvent-compatible substrates.
- A range of HP recyclable substrates are available.
- Consider unlaminated use with scratch resistance comparable to hard solvent inks on SAV and PVC banners
- Expand your offerings with the glossiest white.
 - Deliver the glossiest white on transparent and colored substrates, with high-opacity white HP Latex ink that resists yellowing over time.
 - No waste between white jobs, with removable HP Thermal Inkjet printheads stored in the offline rotating chamber.
 - White-ink automatic maintenance makes white like any other color, with automatic recirculation, automatic nozzle checks, and simple workflows.

To send print jobs to your printer, you will need Raster Image Processor (RIP) software, which should be run on a separate computer. RIP software is available from various companies.

Documentation and useful links

Documentation

Full documentation is available for your product.

The following documents can be downloaded from: <https://www.hp.com/go/latexR530/manuals>

- Introductory information
- Site preparation guide
- Printer assembly instructions
- User guide
- Legal information
- Limited warranty

The Quick Response (QR) code images found in some parts of this guide provide links to additional video explanations of particular topics.

Useful links

Visit the HP Latex Knowledge Center where you can find detailed information about our HP Latex products and applications, and use the forum to discuss anything related to the business.

Visit the HP Latex Knowledge Center at <http://www.hp.com/communities/HPLatex>.

Product documentation: <https://www.hp.com/go/latexR530/manuals>.

Videos about how to use the printer: <http://www.hp.com/supportvideos/> or <http://www.youtube.com/HPsupportAdvanced>.

Information about software RIPs, applications, solutions, inks, and substrates: <http://www.hp.com/go/latexR530/solutions/>.

Substrate presets: <http://www.hp.com/go/mediasolutionslocator> (see [Online search - HP Media Locator on page 87](#)).

HP Support: <https://www.hp.com/go/latexR530/support>.

When you need help

In most countries, support is provided by HP support partners (usually the company that sold you the printer). If this is not the case in your country, contact HP Support on the Web as shown above.

Help is also available to you by telephone. What to do before you call:

- Review the troubleshooting suggestions in this guide.
- Review your RIP's documentation, if relevant.
- Please have the following information available:

- The printer you are using: the product and serial numbers



NOTE: This information is available from the control panel: tap . You may also find it on a label at the rear of the printer.

- If there is an error code on the control panel, note it down; see [System error codes on page 200](#)
- The RIP you are using, and its version number

- If you have a print-quality problem: the substrate reference, and the name and origin of the substrate preset used to print on it.
- The service information report (see [Service information on page 3](#))

Telephone number

Your HP Support telephone number is available on the Web.

Please visit http://welcome.hp.com/country/us/en/wwcontact_us.html.

Service information

The printer can produce on request a list of many aspects of its current status, some of which may be useful to a service engineer trying to fix a problem.

To request this list:

If you need to send the list by email, you can save the page as a file from your Web browser, and later send the file. Alternatively, from Microsoft Edge you can send the page directly: select **File > Send > Page by email**.

Safety precautions

Before using your printer, read, understand, and follow these safety precautions, and your local Environmental, Health, and Safety regulations.

This equipment is not suitable for use in locations where children are likely to be present. For any maintenance or part replacement, follow the instructions provided in HP documentation to minimize safety risks and to avoid damaging the printer.

General safety guidelines

Please read these safety guidelines carefully.

There are no operator-serviceable parts inside the printer except those covered by HP's Customer Self Repair program: see <http://www.hp.com/go/selfrepair>. Refer servicing of other parts to qualified service personnel.

Turn off the printer and call your service representative in any of the following cases:

- A power cord or plug is damaged.
- The curing enclosures are damaged.
- The printer has been damaged by an impact.
- There is any mechanical or enclosure damage.
- Liquid has entered the printer.
- There is smoke or an unusual smell coming from the printer.
- The printer has been dropped or the curing module has been damaged.
- The printer is not operating normally.

Turn off the printer in either of the following cases:

- During a thunderstorm
- During a power failure

Take special care with zones marked with warning labels.

Electrical shock hazard

 **WARNING!** The internal circuits of curing zones, curing driver and built-in power supply operate at hazardous voltages capable of causing death or serious personal injury.

The printer uses two power cords. Unplug both power cords before servicing the printer.

To avoid the risk of electric shock:

- The printer must be connected to earthed mains outlets only.
- Do not attempt to dismantle the curing modules.
- Do not remove or open any closed system covers or plugs.
- Do not insert objects through slots in the printer.

Heat hazard

The drying and curing subsystems of the printer operate at high temperatures and can cause burns if touched.

Printzone lights, beam and enclosures can reach high temperatures. To avoid the risk of burns, take the following precautions:

- Do not touch the internal enclosures of the printer's drying and curing modules.
- Take special care when accessing the substrate path.
- Take special care with zones marked with warning labels.
- Do not place objects covering Printzone lights, beam and enclosures.
- Do not attempt to modify Printzone lights, beam and enclosures;
- Remember to let the printer cool down before performing some maintenance operations.

Fire hazard

The curing subsystems of the printer operate at high temperatures.

To avoid the risk of fire, take the following precautions:

- Check that the power supply meets the requirements specified in the site preparation guide.
- Connect the power cords to dedicated lines, each protected by a branch circuit breaker according to the rating of the wall socket. Do not use a power strip (relocatable power tap) to connect the power cords.
- Do not use aerosol products that contain flammable gases inside or around the printer.

- Take care not to spill liquid on the printer. After cleaning, make sure all components are dry before using the printer again.
- Do not insert objects through slots in the printer.
- Do not use the printer in an explosive atmosphere.
- Do not use a damaged power cord. Do not use the power cords with other products.
- Do not block or cover the openings of the printer.
- Ensure that the operating temperature of the substrate, as recommended by its manufacturer, is not exceeded. If this information is not available, ask the manufacturer. Do not load substrates that cannot be used at an operating temperature above 125°C (257°F).
- Do not load substrates with auto-ignition temperatures below 250°C (482°F). If this information is not available, printing must be supervised at all times. See note below.

 **NOTE:** Test method based on EN ISO 6942:2002: Evaluation of materials and material assemblies when exposed to a source of radiant heat, method B. The test conditions to determine the temperature when the substrate starts ignition (either flame or glow) were: Heat flux density: 30 kW/m², copper calorimeter, K-type thermocouple.

Mechanical hazard

The printer has moving parts that could cause injury. To avoid personal injury, take the following precautions when working close to the printer:

- Keep your clothing and all parts of your body away from the printer's moving parts.
- Avoid wearing necklaces, bracelets, and other hanging objects.
- If your hair is long, try to secure it so that it will not fall into the printer.
- Take care that sleeves or gloves do not get caught in the printer's moving parts.
- Avoid standing close to the fans, which could cause injury and could also affect print quality (by obstructing the air flow).
- Do not touch gears or moving rolls during printing.
- Do not operate the printer with covers bypassed.
- Ensure that nobody else is close to the printer while loading substrate.
- Ensure that the carriage has stopped in the service station before you open the carriage door, or lift the curing module.

Light radiation hazard

Light radiation is emitted from the illumination of the print zone.

This illumination is in compliance with the requirements of the exempt group of IEC 62471:2006: *Photobiological safety of lamps and lamp systems*. However, you are recommended not to look directly at the LEDs while they are on. Do not modify the module.

Chemical hazard

Safety data sheets are available.

See the safety data sheets available at <http://www.hp.com/go/msds> to identify the chemical ingredients of your consumables. Sufficient ventilation needs to be provided to ensure that potential airborne exposure to these substances is adequately controlled. Consult your usual air-conditioning or EHS specialist for advice on the appropriate measures for your location.

For more detailed information, see the **Ventilation** and **Air conditioning** sections included in the site preparation guide, available at: <https://www.hp.com/latexR530/manuals>.

Ventilation

Ensure that the room in which the system is installed meets local environmental, health, and safety (EHS) guidelines and regulations.

Fresh air ventilation is needed to maintain comfort levels. Adequate ventilation needs to be provided to ensure that potential exposure is adequately controlled. Consult the Safety Data Sheets available at <http://www.hp.com/go/msds> to identify chemical ingredients of your ink consumables.

Airborne materials can be readily identified and quantified by using established indoor air-quality testing protocols. HP performs these assessments during the development phase for all products.

HP testing shows that, during printer operation, the concentrations of airborne contaminants measured in the workspace are consistently well below key occupational exposure limits. This observation is based on exposure assessments that model very active productivity at customer facilities. Customers should recognize that actual levels in their facilities are dependent on workspace variables they control such as room size, ventilation performance, and duration of equipment use.

HP's assessment concluded that, based on the available scientific information, airborne materials generated during the printing process are not expected to present a health hazard as long as you provide a minimum of 5 ACH (air changes per hour) of fresh air ventilation and a minimum room volume of 60 m³ (2119 ft³).

These specifications are valid for one HP printer using a black area-fill print at 6 passes and 90% ink density, assuming 8 h printing time per day. If there is other equipment in the room or different printing conditions, the ventilation rate should be recalculated accordingly.

As an alternative to the workspace benefit provided by general room ventilation, you could choose localized ventilation to provide a more comfortable working environment.

Air conditioning

In addition to fresh air ventilation to avoid health hazards, consider also maintaining workplace ambient levels by ensuring the climatic operating conditions (specified in the user guide) to avoid operator discomfort and equipment malfunction. Air conditioning in the work area should take into account that the printer produces heat.

Typically, the printer's power dissipation is 4 kW (13.7 kBTU/h).

Air conditioning should meet local Environmental Health and Safety (EHS) guidelines and regulations.



NOTE: The air-conditioning units should not blow air directly onto the equipment.

Heavy substrate hazard

Special care must be taken to avoid personal injury when handling heavy substrates.

- Handling heavy substrate rolls always requires two people. Care must be taken to avoid back strain and/or injury.
- Consider using a forklift, pallet truck, or other handling equipment.
- When handling heavy substrate rolls, wear personal protective equipment including boots and gloves.
- Use the loading accessories (loading table extension and lifter) when you load substrate rolls.

Ink handling

HP recommends that you wear gloves when handling ink system components.

Warnings and cautions

The following symbols are used in this manual to ensure the proper use of the printer and to prevent the printer from being damaged.

Follow the instructions marked with these symbols.

- ⚠ **WARNING!** Failure to follow the guidelines marked with this symbol could result in serious personal injury or death.
- ⚠ **CAUTION:** Failure to follow the guidelines marked with this symbol could result in minor personal injury or damage to the printer.

Warning labels

You will find labels with safety advice on various parts of your printer.

Table 1-1 Warning labels



| Label | Explanation |
|-------------------------------------------------------------------------------------|------------------------------------------------------|
|  | Printer label. To identify the printer's power cord. |
|  | Curing label. To identify the curing power cord. |

Table 1-1 Warning labels (continued)





| Label | Explanation |
|-------------------------------------------------------------------------------------|---------------------------------------------------------------------------------------------------------------------------------------------------------------------------------------------------------------------------------------------------------------------------------------------------------------------------------------------------------------------------------------------------------------------------------------------------------------------------------------------------------------------------------------------|
|  | <p>High leakage current. Do not touch the plug pins of any printer or curing component without waiting at least two seconds after unplugging it. Heating modules operate at hazardous voltages. Disconnect all power sources before servicing.</p> <p>CAUTION: Double pole, neutral fusing.</p> <p>Connect the equipment only to an earthed mains outlet.</p> <p>No operator-serviceable parts inside.</p> <p>Before starting, read and follow the operating and safety instructions.</p> <p>This label is located on the e-box.</p> |
|  | <p>Risk of burns. Do not touch the curing zone or the output platen of the printer: they could be hot.</p> <p>This label is located on the front of the curing module and on the bottom part of the output platen.</p> |
|  | <p>Risk of entrapment</p> <p>Be careful when you take the media roll for the bottom part. You could trap your finger between the media roll and the Mimo bars.</p> <p>Located on each media loading table.</p> |
|  | <p>You are recommended to wear gloves when handling the waste container.</p> <p>This label is located on the maintenance cartridge.</p> |

Table 1-1 Warning labels (continued)











| Label | Explanation |
|-------------------------------------------------------------------------------------|-------------------------------------------------------------------------------------------------------------------------------------------------------------------------------------------------------------------------------------------------------------------------------------------------------------------------------------------------------------------------------------------------------------------------------------------------------------------------------------------------------------------------------------------------------------------------------------------------------------------------------------------------------------------------------------------------------------------------------------|
|  | <p>Electric shock hazard. PSU units operate at hazardous voltages.</p> <p>Curing converter PCAs operate at hazardous voltages.</p> <p>Curing heater modules operate at hazardous voltages.</p> <p>Regen heater module operates at hazardous voltages.</p> <p>Disconnect all power sources before servicing.</p> <p>These labels are located on:</p> <ul style="list-style-type: none"> • Inside the EEbox near PSU units. • Inside the EEbox on the curing converter PCAs fans pipe. • On the top of the regen system pipe. • On the curing recirculation cover. |
|  | <p>Electric shock hazard.</p> <p>Disconnect power before servicing.</p> <p>Emergency stops and vacuum pumps operate at hazardous voltage.</p> <p>Located on ID cover close to E-Stop buttons and AC Vacuum pumps.</p> |
|  | <p>Hazardous moving parts. Rotating fan blades. Keep hands clear.</p> <p>Located in the Printzone fans area.</p> |
|  | <p>The contents of the condensation collector should not be dumped down the drain, but should be disposed of in accordance with local regulations and site operation. The waste profile datasheet contains the information required for adequate disposal; it can be found at https://hplatexknowledgecenter.com/applications/wasteprofiles/.</p> <p>Do not drink the contents of the condensation collector.</p> <p>You can obtain current Material Safety Data Sheets for the ink systems used in the printer from http://www.hp.com/go/msds</p> <p>This label is located on the condensation collector.</p> |

Table 1-1 Warning labels (continued)

| Label | Explanation |
|-------------------------------------------------------------------------------------|----------------------------------------------------------------------------------------------------------------------------------------------------------------------------------------------------------------------------------------------------------------------------------------------------------------------------------|
|  | <p>Crush Hazard.</p> <p>When the substrate has been loaded, the Curing subsystems descend into their normal positions, and could crush your hand or anything else left underneath it.</p> <p>Located on alignment bar, printzone ID sides and output roller.</p> |
|  | <p>Risk of fingers trapped.</p> <p>Danger that your hands may become trapped between belt roller and belt while moving.</p> <p>Located on ID near belt rollers on media output and on output roller</p> |
|  | <p>Risk of cutting your fingers.</p> <p>Do not put your finger in the hole created between the output plate and the ID when output plate is in its lower position.</p> <p>Located on ID cover near output roller.</p> |
|  | <p>Read the manuals.</p> <p>Be careful when standing up after placing a media roll on the input roller, as you may hit with your head on belt roller's cover.</p> <p>This is located on the ID near the belt rollers on the media input.</p> |
|  | <p>Identifies the Protective Earth (PE) terminal for qualified electricians, while the bonding terminals are intended for maintenance/service personnel only.</p> <p>Earth connection essential before connecting the power supply.</p> <p>These are located on the ID internal structure of the curing module and the E-box</p> |

 **NOTE:** The final label position and its size on the printer may vary slightly, but should always be visible and close to the potential risk area.

Main printer components

The following views of the printer illustrate its main components.

Front view

Parts visible from the front of the printer.

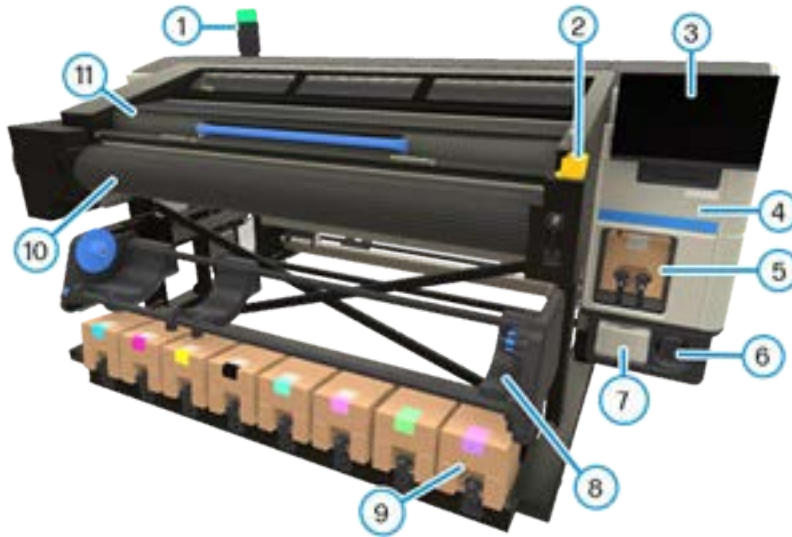

1. Beacon
2. Emergency-stop button
3. Touchscreen
4. Maintenance-cartridge door
5. White Eco-Carton ink cartridges
6. White-printhead storage system
7. Water tank
8. Take up reel
9. Eco-carton ink cartridges
10. Media advance belt
11. Curing module

Rear view

Parts visible from the rear of the printer.

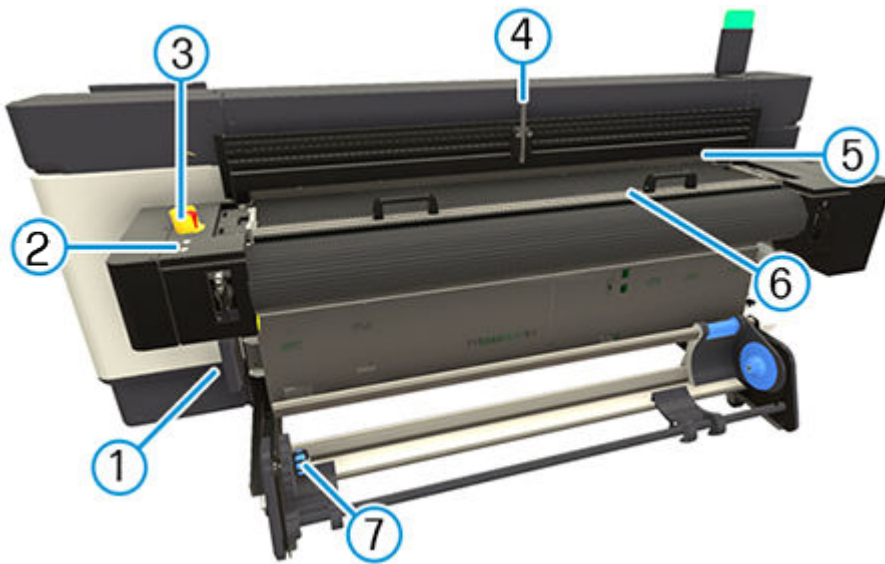

1. IPS computer
2. Media load buttons
3. Emergency-stop button
4. N-Up pin
5. Alignment bar
6. Hold Down plate
7. Spindle-less roll rewinder

Carriage view

Parts visible from the rear of the printer.

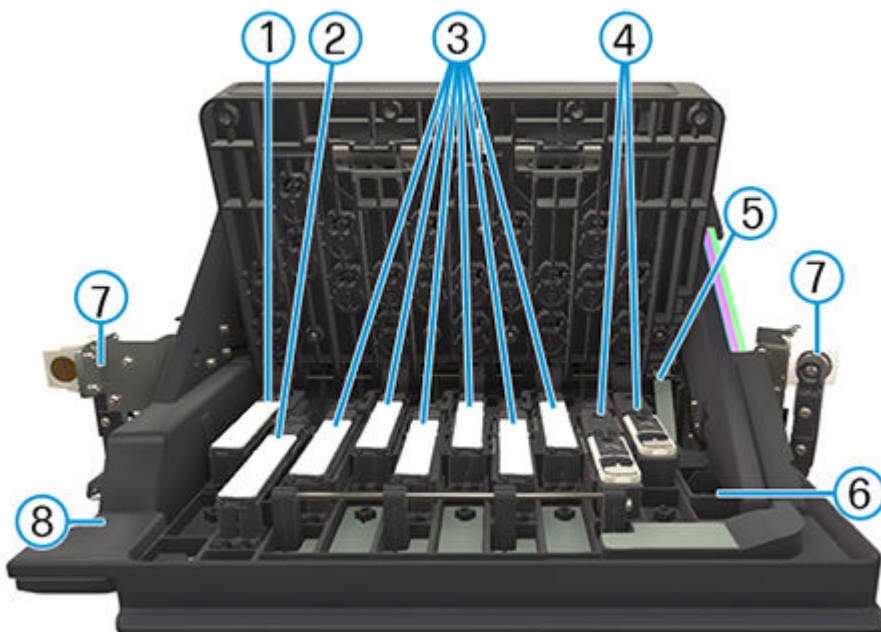

1. Optimizer printhead
2. Overcoat printhead
3. Color printheads
4. White printheads
5. Encoder sensor
6. Line sensor
7. Crash sensors
8. HP Embedded Spectrophotometer

Media load buttons

The set of buttons and LEDs in the media input.



1. Media type selection - Toggles between sheet and roll loading.
2. Media load - When the button light is solid (not blinking), pressing this button starts the loading process.
3. Sheet media - A blinking light indicates the printer is preparing for sheet loading. A solid light indicates sheet substrate is selected.
4. Roll media - A blinking light indicates the printer is preparing for roll loading. A solid light indicates "roll substrate" mode is selected.

Beacon

The beacon provides a simple indication of printer status that is visible from a distance, so that you can easily see whether it is working normally.

If there is a problem, the beacon color gives an indication of the type of problem.

Table 1-2 Beacon

| Beacon color | Meaning |
|-----------------|------------------------------------------------------------------------------------------------------------------------------------------------------------------------------------------------------------|
| Green | Printer ready (may or may not have substrate loaded). |
| Blinking green | Printing without any warning. |
| Yellow | Printer requires user intervention which, if not performed, may prevent printing. 3-liter Eco-Carton ink cartridge is not present or out of ink, distilled water tank empty. |
| Blinking yellow | The printer requires user intervention while printing: the 3-liter Eco-Carton ink cartridge is not present or out of ink while printing, or rigid material needs to be loaded in continuous printing mode. |
| Red | There is a problem that prevents or interrupts printing: the Maintenance Cartridge is full or not present, a cover is open, or the printer engine has failed. |

Printer software

This section provides the relevant information.

Your printer requires two software components:

- The HP Internal Print Server, which comes pre-installed with your printer. It displays printer alerts on the touch screen, provides a summary of the printer's status, manages print jobs, and is required for interacting with the printer. For more information, see [HP Internal Print Server on page 21](#)
- The Raster Image Processor (RIP) must be installed on a separate computer and cannot be installed on the printer's built-in system. The RIP is not included with the printer and must be obtained separately. The printer supports JDF. If your RIP is JDF-compatible, it can retrieve and display printer and job status.

HP PrintOS

HP PrintOS is a Web-based operating system for your business—an open and secure cloud-based platform.

It drives productivity and inspires innovation with a unique suite of apps that deliver greater control while also simplifying production processes.

Signing up is the first step to enjoy the benefits of the completely new HP PrintOS, your cloud-based print-production operating system. If you need help to connect your printer to HP PrintOS, see [Adding your printer to HP PrintOS](#).

PrintOS advantages

- **Get control over your fleet production**

Stay on top of production even when you're away from your printer, and get data-driven insights for better decision-making and continuous improvements.

- **Easily configure your substrates remotely**

Put an end to repetitive and time-consuming processes. Backups are automatic, and you can easily restore substrate configurations.

- **Catch new growth opportunities**

Easily integrate Web-to-print decoration and signage design tools into your website and unleash your online print business potential.

PrintOS solutions

- **PrintBeat:** Remotely monitor your print production, access and download printer job information, and make effective data-driven decisions to keep improving your operations.
- **PrintOS Mobile App:** Control your print operations virtually anytime, anywhere by monitoring printer status, ink and substrate consumption, view completed jobs, and immediately identify printing issues even while on the go.
- **Configuration Center:** Remotely configure your large-format printer from any location by managing, accessing, and deploying all your printer's substrate configuration from a single place, to simplify and balance your print operations.
- **Applications Center:** Get print-ready PDF files by enabling your customers to design a variety of large-format decorative or signage applications in just minutes.
- **Service Center:** Access all service activities directly from a single portal, providing you with quick, efficient, and reliable management of service cases.

PrintOS offers three additional premium solutions, available for Professional Print Service Plan (PPSP) Plus subscribers:

- **HP PrintOS Live Production:** Streamline operations and confidently print unattended with remote production control of your printers' queues to anticipate and react to issues - on both your desktop and mobile. Visualize the status of all your printers and jobs in a single interface.
- **HP Print Beat-Jobs API:** Export your printer and production data to your preferred MIS and ERP solution.
- **HP Learn-Premium training catalogues:** Upskill and grow your business with advanced training content, such as in-depth application videos and recorded webinars, with subtitles available in 12 support languages.
- **HP Design & eCommerce:** Grow your online business and simplify your production workflow with a plug and play web-to-print solution specially created for the Large Format Printing Industry.

For more information on the Professional Print Service Plans, see www.hp.com/us-en/printers/large-format/professional-print-service-plans.

Connectivity and job submission

Information regarding network connection, configuration, and job submission methods to configure in the RIP software.

Connection method

Your printer can be connected through the built-in Gigabit Ethernet port of the integrated Internal Print Server.

NOTE: The speed of any network connection depends on all components used in the network, including network interface cards, hubs, routers, switches, and cables. If any of these components cannot operate at high speed, the connection will be slow.

To achieve the expected printer performance, use equipment that supports 1000TX Full Gigabit.

Network speed can also be affected by total traffic from other devices on the network.

Network configuration

Network configuration can be changed from the **Connectivity** menu in the **Preferences** window (**IPS** → **Preferences** → **Connectivity**).

Preferences button



By default, IP and Proxy settings are setup for automatic configuration, but it can be changed to manual configuration:



Job submission methods

The printer supports three file submission methods.

- **Hot folder:** The Internal Print Server retrieves jobs from a shared folder. The RIP copies the output job, and the Internal Print Server automatically loads them into the queue. The default hot folder in the Internal Print Server is *C:\output*, but it can be changed in the **Connectivity** menu.

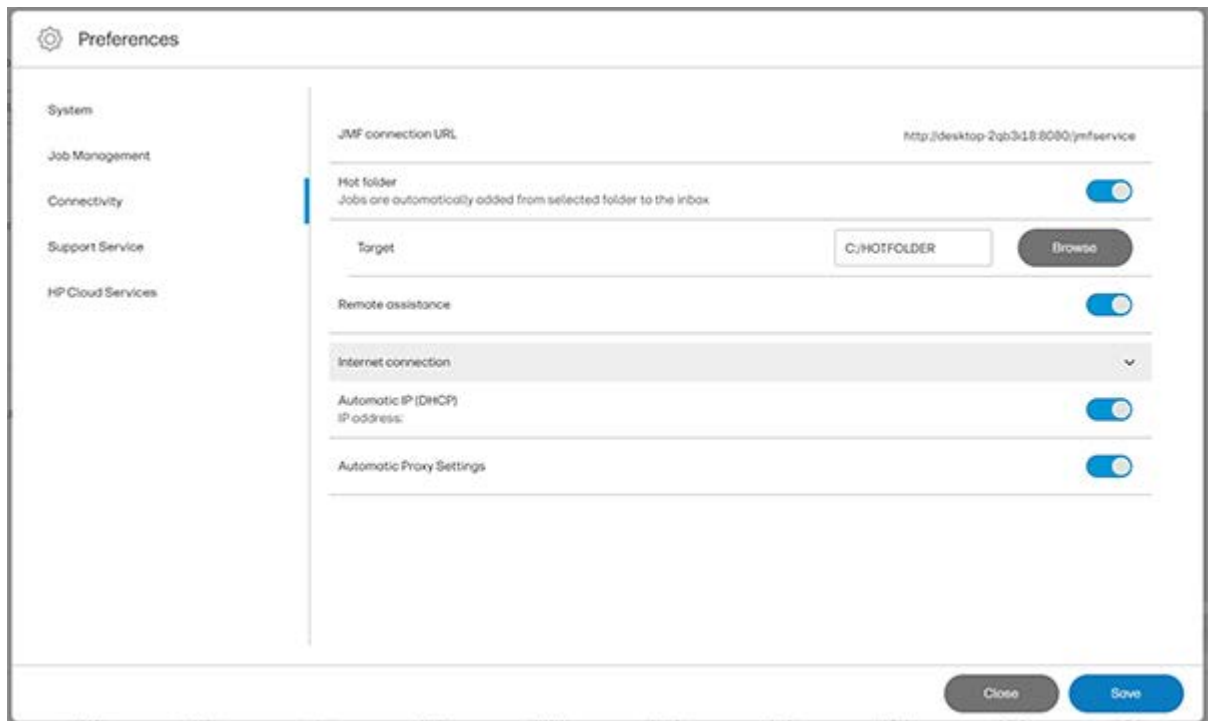

 **NOTE:** The shared folder should be the same as the one configured in the RIP.

If the JMF and Hot Folder options have the same shared folder configured, jobs may arrive in the queue duplicated.

- **JMF:** The RIP sends the location of the job via a JMF command; the Internal Print Server automatically looks for the files there and loads them directly into the printer queue. You can remove a job from the Internal Print Server or printer queue directly from the RIP interface, but only if it was submitted using the JMF method.

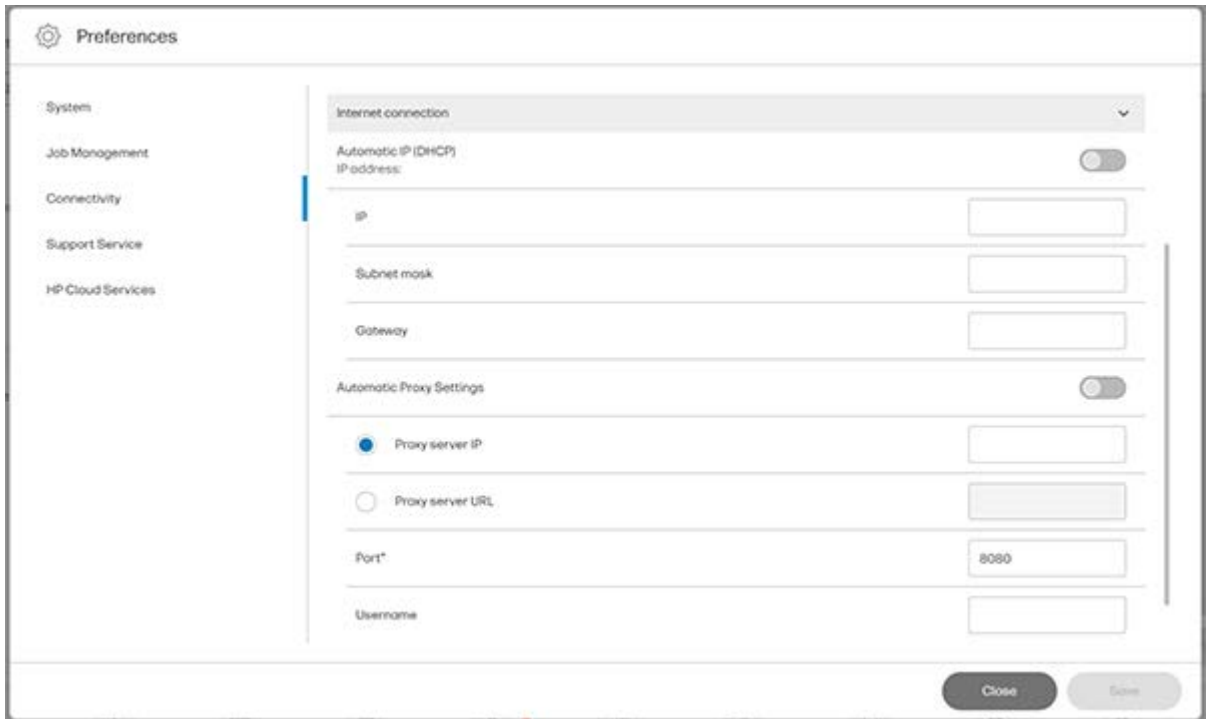

- **Open a file directly in the Internal Print Server:** Load the file manually in the Internal Print Server from the queue.

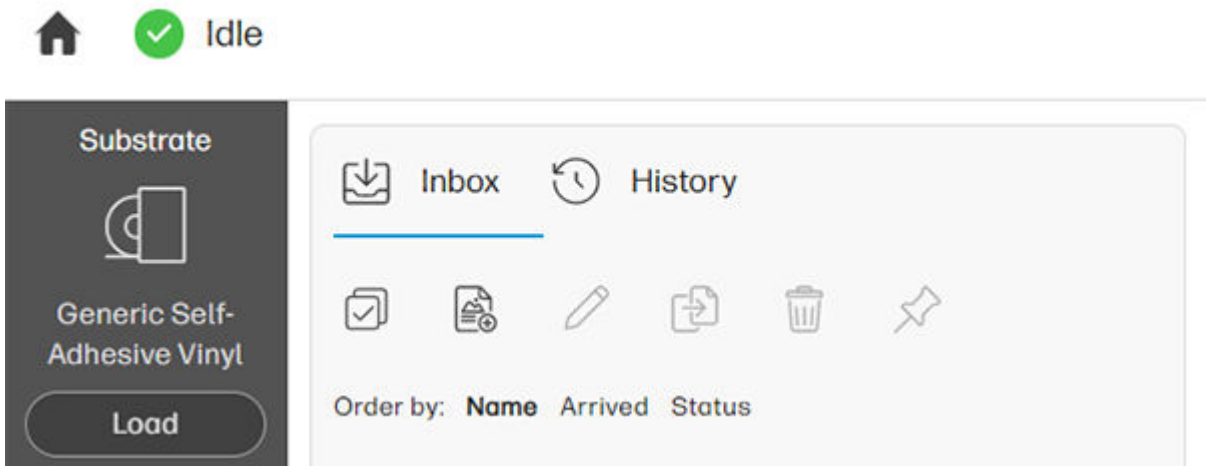

 **NOTE:** For details about how to configure the RIP software refer to the Installation guide and the instructions provided with the software.

Turn the printer on and off

For the purposes of normal use, the printer can be turned on and off from the Internal Print Server.

The printer has four modes, which you can access by selecting the power button displayed in the top-right corner of the Internal Print Server.



Power levels

1. **Start in normal mode.** Turn the printer on in normal operation mode. If the printer is already on, this function will restart it.
2. **Switch to diagnostic mode.** Mode used by the operator or the service engineer. At this level, you can perform maintenance and diagnostic operations, blocking high-voltage lines for safety when manipulating internal parts of the printer.
3. **Switch to low power mode.** Low power mode reduces the power required by the printer when it is not in use and allows the printer to perform regular maintenance when needed. The printer can automatically enter low-power mode after a period configured in the printer's settings.
4. **Shut down.** The printer is off.

 **IMPORTANT:** The printers should never be turned off; use low-power mode instead. Automatic white-ink maintenance cannot occur when the printer is completely turned off, and the white-ink printheads cannot remain inactive for more than 8 hours without maintenance. The low-power mode timer can be configured in the System menu from the Preferences window.

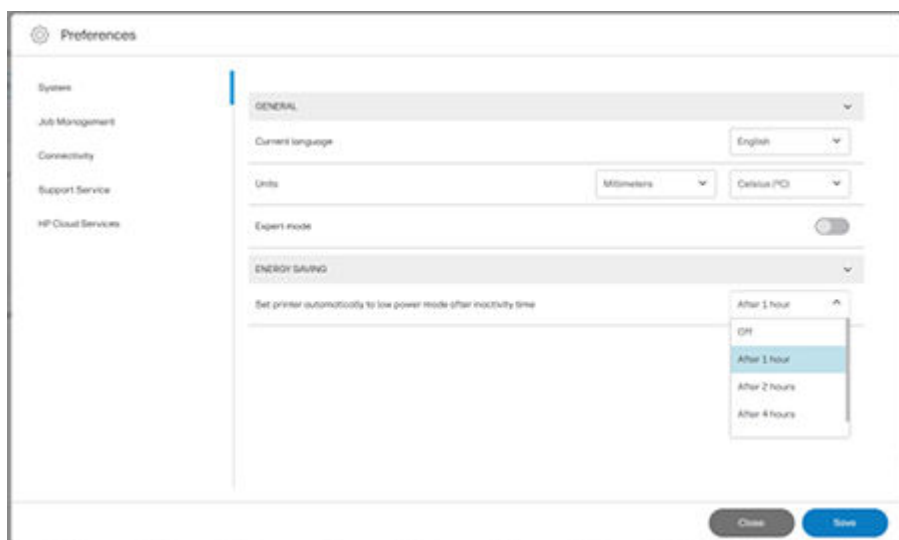

Restart the printer

In some circumstances you may be advised to restart the printer.

1. Turn off the printer from the Internal Print Server and then unplug the two power cords at the rear of the printer.
2. Wait for 10 seconds.
3. Plug in the two power cords at the rear of the printer.
4. If the control panel does not activate, press the power button.

2 HP Internal Print Server

The following sections provide details for this topic.

Start the Internal Print Server

The Internal Print Server starts automatically with Windows on the printer's built-in computer, and runs continually, in the background if not in the foreground.

It is displayed on a touchscreen, so you must use it by tapping or swiping items on the screen.

When it starts, the main window appears.

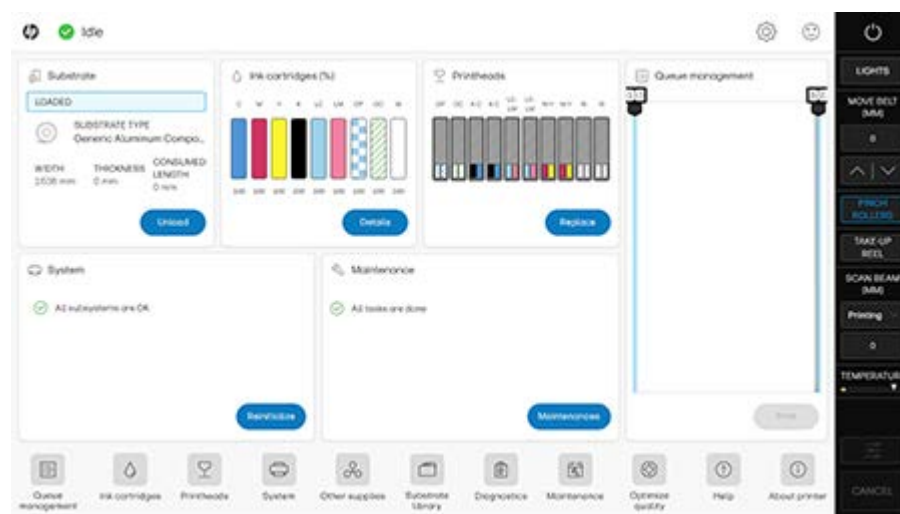

The main window is divided between different widgets, with which you can view and manage the operation of the printer:

- Information about printer supplies: substrate, inks, and printheads
- Information about printer subsystems
- Information about printer maintenance
- Information about the print queue, including the print preview and **Print** button.

You can tap any widget for further information.

From the app bar at the bottom of the window, you can check and configure the printer applications.

Tap the queue management widget to reach the queue management window.

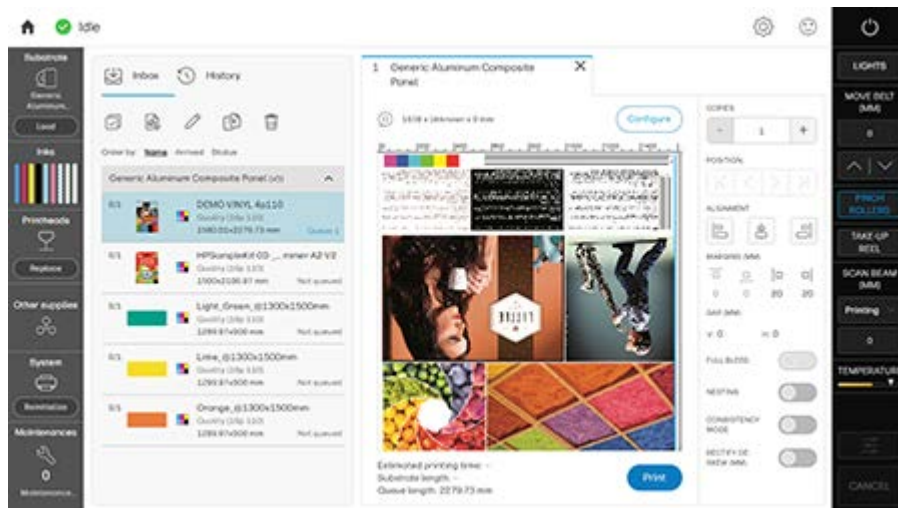

- Most of the left half of the window is occupied by the Inbox tab or the History tab. The Inbox shows jobs that are waiting to be printed, and the History shows jobs that have been printed. The jobs in the Inbox are organized according to the substrate on which they will be printed. After printing, each job moves from the Inbox to the History.

In this section, you can tap a job to see more information about it.

To start a queue, select jobs from the Inbox on the left, and drag and drop the selected jobs to the right.



TIP: You can select several jobs and drag them at the same time.

- Most of the right half of the window is occupied by the preview of the queue, with settings and selected jobs.
- The vertical bars on each side of the window provide further information and action buttons: the same buttons that exist on the printer, but with more options.
- In the **History** tab, you will find information about the jobs that you have recently printed.
- For complete accounting, register your printer in PrintOS, where you can find much more complete statistical data, as well as the possibility of downloading them for processing with other software.

Internal Print Server widgets

The Internal Print Server provides the following widgets:

- The **Substrate** widget helps you to identify the loaded substrate and to change its properties. You can also use it to load or unload the substrate. You can check the type and the size of the loaded substrate.
- The **Ink cartridges** widget shows the amount of ink in the cartridges. In the expanded view, you can see detailed information on each cartridge, including its expiry date and serial number.
- The **Printheads** widget shows the status of each printhead, and gives a graphical illustration of any issue. You can also use it to start printhead alignment and replacement processes.
- The **Queue management** widget shows the status of the printer and the job queues.

- The **System** widget shows the status of the printer subsystems, with alerts, system errors, and other information about the health of the system. From here you can reinitialize a subsystem without restarting the whole printer, which allows you to recover quickly from a substrate jam.
- The **Maintenance** widget shows the complete list of printer maintenance tasks, sorted by the dates on which they are next due. There is a Today section for tasks that should be done immediately, and an Overdue section for tasks that should have been done already. You can see in the list the frequency of each task, the time needed to execute it, and security considerations; and you can launch a maintenance task.

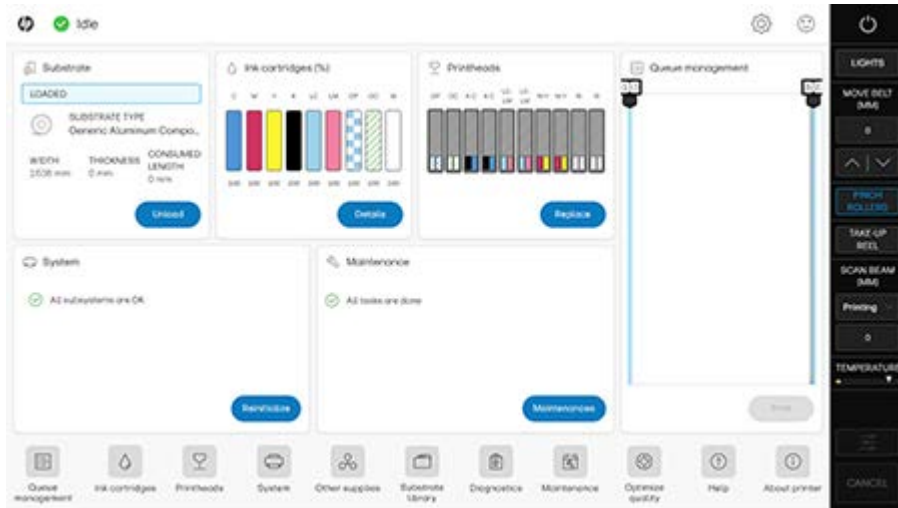

Printer status and alerts

The Internal Print Server displays the general status of the printer.

General notifications appear in the system widget; more specific alerts appear in the appropriate widget (see [Internal Print Server widgets on page 22](#)).

Tap the widget for more information about the alert.

Update the printer's firmware and software (Internal Print Server)

From time to time, firmware and software updates will be available from HP that increase the printer's functionality and enhance its features.

IMPORTANT: HP recommends an external LAN connection for this procedure, as it allows you to automate some procedures, and simplifies the process. The following sections provide instructions for each situation.

TIP: When updating the firmware and the Internal Print Server, first update the firmware and then the Internal Print Server.

Automatic firmware and software updates

When a LAN connection is available, the Internal Print Server periodically checks whether a new update package has been published by HP.

If a new update is available, it is automatically downloaded and presented in the Internal Print Server as a “New firmware and software release”, visible in the Maintenance window.

When the Internal Print Server computer is started for the first time, it takes a few minutes to download the update package and display the notice in the Maintenance window.

1. Tap **Maintenances** to display the list of maintenances.

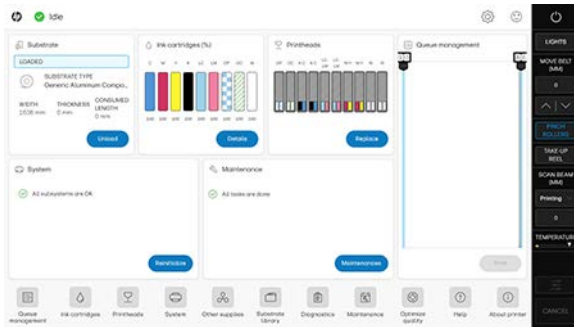

2. Tap the new firmware and software release to view the instructions.

| Task | Due date | Next action | Estimated duration | Last attention | Status | Priority |
|--------------------------------------------------------------------------------------------------------------------------|------------|------------------|--------------------|----------------|--------|-------------|
| <input type="checkbox"/> Unblock | | | | | | |
| <input type="checkbox"/> Replace the left-side drum | --- | ink cleaning kit | 5 Minutes | --- | 100% | Subcritical |
| <input checked="" type="checkbox"/> New firmware and software release available (Single task: MS 21.627_21_01.1.01.10.1) | --- | | 20 Minutes | --- | 100% | Subcritical |
| <input type="checkbox"/> Clean the toner/cyan drum caps | 03/24/2021 | Cleaning kit | 5 Minutes | --- | 10.0% | Weekly |
| <input type="checkbox"/> Clean the printhead cleaning roll (blue) | 03/23/2021 | Cleaning kit | 5 Minutes | --- | 90.0% | 2 Day |
| <input type="checkbox"/> Clean the printhead cleaning roll (blue for color) | 03/24/2021 | Cleaning kit | 10 Minutes | --- | 10.0% | Weekly |
| <input type="checkbox"/> Clean the left printhead cleaning head | 03/24/2021 | Cleaning kit | 5 Minutes | --- | 10.0% | Weekly |
| <input type="checkbox"/> Clean the printhead paper plate and fillets | 03/24/2021 | Cleaning kit | 5 Minutes | --- | 10.0% | Weekly |

3. You may need to update the firmware and the Internal Print Server from two different buttons.



 **IMPORTANT:** In this case, update the firmware first, then the Internal Print Server. After updating the firmware, do not forget to update the Internal Print Server.

4. Alternatively, one button may be provided to update both.

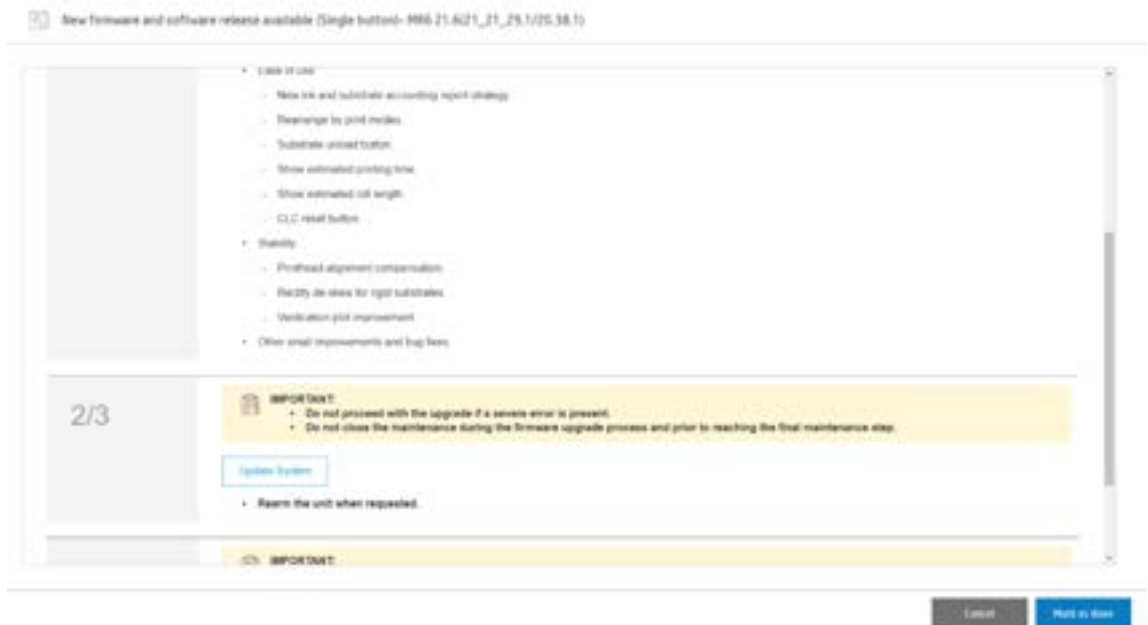

The printer will restart during the upgrade process, and the Internal Print Server will close and restart. Eventually the Internal Print Server computer will also need to be restarted.

Manual firmware and software updates

The system may be manually updated for any reason, typically when it has no LAN connection.

Firmware, Internal Print Server, and maintenance updates can be downloaded from the Internet and installed in your printer using the Internal Print Server.

1. Download the latest update files from the hp.com website onto your computer's hard disk (preferably in a dedicated folder, not on the desktop) and unzip all the files. You will find three files: a firmware package (*.fmw), an Internal Print Server installer (HPIPS-*-installer.exe) and a maintenance installer (HPIPS-*-Maintenances.exe).
2. Copy the three files to a USB device, placing them in the same folder. Plug the USB device into the socket on the Internal Print Server monitor.
3. At the bottom of the Internal Print Server's home screen, tap the **About** icon  to open the **About** window.



4. Tap **Update firmware**.
5. A file browser window opens. Navigate to the USB device and look for the firmware update file. Select it by tapping **Open**.
6. The firmware is uploaded to the printer. A progress bar is displayed while it is uploading.



7. On completion, the Internal Print Server displays a message confirming the update. Tap **OK** to continue. At this point, the printer should restart without any interaction. If it does not, restart the printer manually.



NOTICE: The first restart after the firmware update takes more time than usual.

8. Back in the **About** window, tap **Update IPS**.
9. A file browser window opens. Navigate to the USB device and look for the IPS update file. Select it by tapping **Open**.
10. The window closes and the installer starts. Follow the onscreen instructions until the new Internal Print Server is installed.
11. If the maintenance update file is in the same folder as the IPS update file, the Internal Print Server installer also installs the maintenance update. However, if you need to install the maintenance update separately for some reason, you can do so as follows.
 - a. Back in the **About** window, tap **Update maintenances**.
 - b. A file browser window opens. Navigate to the USB device and look for the maintenance update file. Select it by tapping **Open**.
 - c. The maintenance installer starts. Follow the onscreen instructions until it finishes.

Internal Print Server settings and preferences

To change the settings or preferences, tap the Settings icon and access the appropriate menu.

 **NOTE:** The language of the HP Internal Print Server can be changed in the settings. But the language and other setting of the Windows OS can not be modified because it could affect the correct behavior of the HP Internal Print Server Application.

Printer diagnostics

The diagnostics menu in the printer contains diagnostic tests. They can be used to troubleshoot issues, and some of them are needed to perform service operations or after certain part replacements.

How to run a diagnostic test

The diagnostics menu can be accessed from the Internal Print Server's main window.

Tap the diagnostics icon . A general menu with all the printer subsystems appears on the left side of the new screen, while the diagnostics contained in each menu appear on the right part of the screen. The diagnostics that appear in this menu depend both on the boot mode of the printer and on the user that is logged in.

Each subsystem has a two-digit code (matching the code numbers for the subsystems in the system errors; see **Troubleshooting Other Issues** → [System error codes on page 200](#)). Each diagnostic also has a numerical identification code, and the two first digits of the diagnostic code match the subsystem. For example, the subsystem Lift mechanisms (48) contains diagnostic 48001 - Lift mechanisms electronic check.

Normally, each one of the menus on the left part of the screen contains diagnostics from a single subsystem. However, certain menus contain diagnostics from several different subsystems.

Inside each subsystem, one or several diagnostics can be selected by tapping on the check-box at the left of the diagnostic code. The selected diagnostics will be executed sequentially; execution will only be stopped if one of the diagnostics fails.

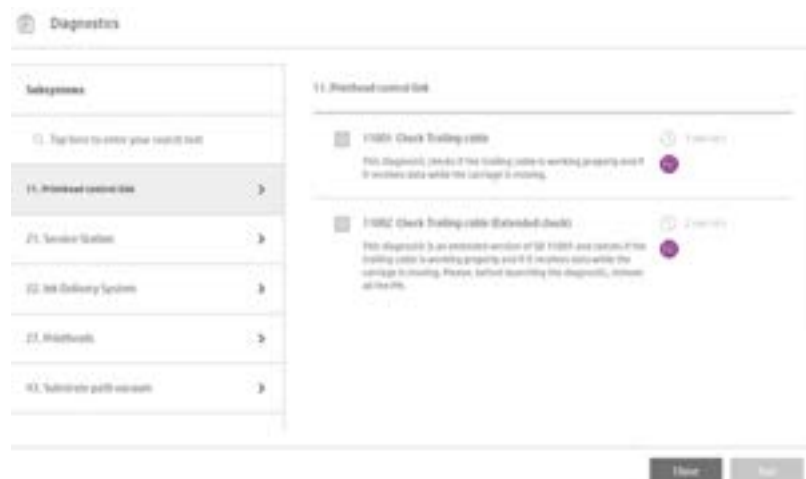

Boot modes

The printer, for diagnostic purposes, can be initialized in two different boot-modes: Normal mode or Diagnostic mode (diagnostics are not available in the Low-power mode).

In **Normal mode** (the default usage mode of the printer), the printer is fully booted. Some diagnostic tests require the printer to have all subsystems available and powered on (for example, diagnostic plots), and for that reason are only available in Normal mode.

In **Diagnostic mode**, the printer initializes only the minimum required components. The rest of components are only started inside each of the diagnostic tests, if required. Some diagnostic tests require starting the printer in a controlled sequence and only powering on the minimum required components. For that reason, they are only available in Diagnostic mode.

There are also some diagnostics that don't have special boot-mode requirements; they are available in both Normal and Diagnostic modes.

Diagnostic mode is also useful when the printer is not able to boot up correctly (for example, a SEVERE system error appears during boot-up, preventing the printer to complete the process). In this case, the only way to run a diagnostic test is by switching to Diagnostic mode and executing the test in this boot-mode.

 **NOTE:** Read the diagnostic's description and perform the exact steps in the instructions.

 **IMPORTANT:** When the printer is started in diagnostic mode, it is unable to print.

Switching boot-mode

To change boot-mode, tap the power button in the Internal Print Server and Switch to the desired boot mode.



TIP: Once the printer is able to communicate with the Internal Print Server, switching modes is possible. This means that the boot-mode can be changed at any time (even after a SEVERE system error, if connectivity is not lost). If a SEVERE system error appears during boot-up and the connectivity is lost afterwards, try to switch the boot-mode before rearming the printer.

User permissions

Some diagnostics require technical knowledge to be executed or should only be executed in certain situations (for example, some calibrations). For that reason, they should only be executed by Service Engineers.

The Internal Print Server allows Service Engineers to log in, in order to access the restricted diagnostic tests.

Diagnostic test availability

The selected boot mode (Normal or Diagnostic) and user role (Service-logged / not logged) define the available diagnostics in the Internal Print Server diagnostics menu.

If a diagnostic is restricted to Normal mode and to the Service role, it will only be available if the printer has been booted up in Normal mode and if a Service Engineer has logged in to the IPS.

Table 2-1 Diagnostic test availability 1/3

| Subsystem | ID | Test name | Available to user | Available in boot mode |
|------------------|-------|------------------------------------------|-------------------|------------------------|
| E-Box | 01001 | Check Printmech Board voltages | Operator,Service | Diagnostic mode |
| | 01002 | Check Printmech Extension Board voltages | Operator,Service | Diagnostic mode |
| Power Management | 10001 | Check Power Supply | Operator,Service | Diagnostic mode |
| | 10002 | Power Supply Functional Test | Operator,Service | Diagnostic mode |

Table 2-1 Diagnostic test availability 1/3 (continued)

| Subsystem | ID | Test name | Available to user | Available in boot mode |
|-------------------|-----------|---------------------------------------|--------------------------|-------------------------------|
| Pipeline Trailing | 11001 | Check Training cable | Operator,Service | Diagnostic mode |
| | 11002 | Check Trailing cable (Extended check) | Operator,Service | Diagnostic mode |
| Curing and Drying | 16001 | Check Curing and Drying system | Service | Diagnostic mode |
| | 16002 | Check Drying Relief lid | Service | Normal mode, Diagnostic mode |
| | 16003 | Check Curing and Drying Mechatronics | Service | Diagnostic mode |
| | 16004 | Monitor one Curing / Drying module | Service | Normal mode, Diagnostic mode |
| | 16005 | Curing performance check plot | Service | Normal mode |
| | 16006 | Curing Homogeneity Calibration | Service | Normal mode |

Table 2-1 Diagnostic test availability 1/3 (continued)

| Subsystem | ID | Test name | Available to user | Available in boot mode |
|-----------------|-------------------------------------|-------------------------------------|-------------------|------------------------------|
| Service Station | 21002 | Check SVS Mechatronics | Operator,Service | Diagnostic mode |
| | 21003 | SVS distance Check | Operator,Service | Diagnostic mode |
| | 21004 | SVS Motor Test | Operator,Service | Diagnostic mode |
| | 21005 | Check Printhead Cleaning Roll motor | Operator,Service | Diagnostic mode |
| | 21006 | Check Cleaning Roll Level | Operator,Service | Diagnostic mode |
| | 21007 | Cleaning Roll Advance test | Operator,Service | Normal mode, Diagnostic mode |
| | 21008 | Check Spit Rollers | Operator,Service | Diagnostic mode |
| | 21009 | Spit Roller Motor Test | Operator,Service | Diagnostic mode |
| | 21010 | Drop Detector Motor Test | Operator,Service | Diagnostic mode |
| | 21011 | Drop Detector test | Operator,Service | Diagnostic mode |
| | 21012 | Move Drop Detector to Safe Position | Service | Diagnostic mode |
| | 21013 | Force drop-detection | Operator,Service | Normal mode |
| | 21014 | Reset Drop Detection Calibration | Service | Normal mode |
| | 21015 | Reset printing-nozzle health data | Operator,Service | Normal mode, Diagnostic mode |
| | 21016 | Display printing-nozzle health data | Operator,Service | Normal mode, Diagnostic mode |
| | 21018 | Display last drop-detection data | Operator,Service | Normal mode, Diagnostic mode |
| | 21019 | Drop Detector calibration | Service | Normal mode |
| 21216 | Display printing-nozzle health data | Service | Normal mode | |

Table 2-2 Diagnostic test availability 2/3

| Subsystem | ID | Test name | Available to user | Available in boot mode |
|---------------------|-------|----------------------------------------------------------|-------------------|------------------------------|
| Ink Delivery System | 22001 | Check IDS Electronics | Operator,Service | Diagnostic mode |
| | 22002 | Check Ink Supplies | Operator,Service | Normal mode, Diagnostic mode |
| | 22003 | Pressure Sensor Functional Test | Operator,Service | Diagnostic mode |
| | 22004 | Pressurization Test | Operator,Service | Diagnostic mode |
| | 22005 | White Pressurization Test | Operator,Service | Diagnostic mode |
| | 22006 | Recover Ink Leakage | Operator,Service | Diagnostic mode |
| | 22007 | Set Color Tubes Purged | Operator,Service | Diagnostic mode |
| | 22008 | Set White Tubes Purged | Operator,Service | Diagnostic mode |
| | 22009 | Refill Intermediate Tanks | Operator,Service | Diagnostic mode |
| | 22010 | Pump White Recovery | Operator,Service | Diagnostic mode |
| | 22011 | White IDS Purge after White SRK replacement (Purgers) | Service | Diagnostic mode |
| | 22012 | White IDS Purge after White IDS HW replacement (Syringe) | Service | Diagnostic mode |
| | 22013 | Current Issues (TPS HV, LDO int, LDO out, TPS LV) | Operator,Service | Diagnostic mode |
| | 22014 | Recirculation Statistics | Operator,Service | Normal mode, Diagnostic mode |
| | 22015 | Force minor recirculation through auxiliary printheads | Operator,Service | Diagnostic mode |
| | 22016 | Force Major Recirculation | Operator,Service | Diagnostic mode |
| | 22017 | Force minor recirculation through white printheads | Operator,Service | Diagnostic mode |
| | 22018 | Empty IT to A | Operator,Service | Diagnostic mode |
| | 22019 | Check Wheel Movement | Operator,Service | Diagnostic mode |
| | 22020 | Check PH Wheel | Operator,Service | Diagnostic mode |

Table 2-2 Diagnostic test availability 2/3 (continued)

| Subsystem | ID | Test name | Available to user | Available in boot mode |
|---------------------|------------|----------------------------------------|-------------------|------------------------------|
| Ink Delivery System | 22021 | White IDS Recovery | Operator,Service | Diagnostic mode |
| | 22022 | EV Acoustic Check | Operator,Service | Diagnostic mode |
| | 22023 | Color pumps flow rate | Service | Diagnostic mode |
| | 22024 | White Pumps Flow Rate | Operator,Service | Diagnostic mode |
| | 22025 | Auxiliary printhead blockage detection | Operator,Service | Normal mode, Diagnostic mode |
| | 22026 | Ink Pressure Sensor White check | Operator,Service | Diagnostic mode |
| | 22027 | Intermediate tanks Information | Operator,Service | Normal mode, Diagnostic mode |
| | 22030 | Air pressure system depressurization | Operator,Service | Diagnostic mode |
| | 22031 | Remove air from tubes | Service | Diagnostic mode |
| | 22033 | IDS Close White Electrovalves | Operator,Service | Diagnostic mode |
| | 22034 | Reset Ink Pump Counters | Service | Diagnostic mode |
| | 22035 | Ink pressure sensor white calibration | Service | Normal mode, Diagnostic mode |
| | 22036 | White Ink Pumps exchange test | Service | Diagnostic mode |
| | Printheads | 27001 | Check Printheads | Operator,Service |
| 27002 | | Check Printheads data Transmission | Operator,Service | Diagnostic mode |
| 27003 | | Run PH Thermal Calibration | Service | Normal mode |
| 27004 | | Advanced PH nozzles health check | Operator,Service | Normal mode |
| 27005 | | Area fill by PH plot | Operator,Service | Normal mode |

Table 2-2 Diagnostic test availability 2/3 (continued)

| Subsystem | ID | Test name | Available to user | Available in boot mode |
|----------------|-------------------------------------------|-----------------------------------------------------|------------------------------|------------------------------|
| Substrate Path | 41001 | Repair substrate database | Service | Normal mode |
| | 41002 | Diagnose Substrate Uniformity | Operator,Service | Normal mode |
| | 41003 | Motors check | Operator,Service | Normal mode, Diagnostic mode |
| | 41005 | Check Autopinch Motor | Operator,Service | Normal mode, Diagnostic mode |
| | 41009 | Substrate Axis test (without substrate) | Operator,Service | Diagnostic mode |
| | 41010 | Search Roller Encoder Zero Position | Operator,Service | Normal mode, Diagnostic mode |
| | 41011 | Skew Test | Operator,Service | Normal mode |
| | 41015 | OPT Analog Encoder Calibration | Service | Normal mode |
| | 41016 | Drive-roller analog-encoder calibration | Service | Normal mode |
| | 41017 | OPT sensor Calibration | Service | Normal mode |
| | 41018 | Drive-roller Calibration | Service | Normal mode |
| | 41019 | Substrate advance sensor check | Operator,Service | Normal mode |
| | 41020 | Drive-roller Check | Service | Normal mode |
| | 41021 | Media advance automatic check (analog and encoders) | Operator,Service | Normal mode, Diagnostic mode |
| | 41022 | Belt sax skew angle Calibration | Service | Normal mode |
| | 41023 | Media Advance Diagnostics Plot | Service | Normal mode |
| | 41024 | Media advance manual check (analog and encoders) | Service | Normal mode, Diagnostic mode |
| | 41025 | Belt tension calibration | Service | Normal mode, Diagnostic mode |
| | 41026 | Belt tension check | Operator,Service | Normal mode |
| | 41027 | Motors calibration | Service | Normal mode, Diagnostic mode |
| | 41028 | Configure improve registration setting | Service | Diagnostic mode |
| | 41029 | Media Advance Check | Service | Normal mode |
| | 41030 | Long boards compensation for belt skew offset | Service | Normal mode, Diagnostic mode |
| 41031 | Service compensation for belt skew offset | Service | Normal mode, Diagnostic mode | |

Table 2-3 Diagnostic test availability 3/3

| Subsystem | ID | Test name | Available to user | Available in boot mode |
|------------------|-----------|-------------------------------|--------------------------|-------------------------------|
| Vacuum | 43001 | Vacuum electronics check | Operator,Service | Normal mode, Diagnostic mode |
| | 43002 | Vacuum system diagnostic | Operator,Service | Normal mode, Diagnostic mode |
| | 43003 | Vacuum manual checks | Service | Diagnostic mode |
| BIOS Formatter | 45001 | Check Formatter PCA | Operator,Service | Diagnostic mode |
| | 45002 | Check Storage | Operator,Service | Diagnostic mode |
| Printer ID | 46001 | Check Electronics | Operator,Service | Diagnostic mode |
| Water Pump | 47001 | Distilled-water water Pump | Operator,Service | Diagnostic mode |
| | 47002 | Distilled-water system purge | Operator,Service | Diagnostic mode |
| | 47003 | Water System | Operator,Service | Diagnostic mode |
| | 47004 | Water Dispenser Hard Recovery | Service | Diagnostic mode |

Table 2-3 Diagnostic test availability 3/3 (continued)

| Subsystem | ID | Test name | Available to user | Available in boot mode |
|----------------------|-------|----------------------------------------------------|-------------------|------------------------------|
| Lift Mechanisms | 48001 | Lift mechanisms electronics check | Operator,Service | Normal mode, Diagnostic mode |
| | 48003 | Lift mechanism movement | Service | Normal mode, Diagnostic mode |
| | 48004 | Lift mechanisms motor open-loop movement | Service | Normal mode, Diagnostic mode |
| | 48005 | Impinging Lifter motor and encoder check | Service | Normal mode, Diagnostic mode |
| | 48006 | Impinging Lifter movement | Service | Normal mode, Diagnostic mode |
| | 48007 | Reinitialize lift mechanism | Operator,Service | Normal mode, Diagnostic mode |
| | 48008 | Check flag status | Operator,Service | Normal mode, Diagnostic mode |
| | 48014 | Alignment bar movement | Service | Normal mode |
| | 48015 | Alignment bar open-loop movement | Service | Normal mode, Diagnostic mode |
| | 48017 | Move lift mechanism to service position | Service | Normal mode, Diagnostic mode |
| | 48020 | Alignment bar measurement | Service | Normal mode |
| | 48021 | Alignment Bar measurement adjustment values update | Service | Normal mode, Diagnostic mode |
| | 48022 | Lateral bar calibration | Service | Normal mode |
| | 48023 | Lift mechanism calibration | Service | Normal mode |
| | 48024 | PBS measurement | Service | Normal mode |
| | 48025 | Update PBS tilt values | Service | Normal mode |
| | 48026 | Update PBS gauges values | Service | Normal mode |
| | 48027 | Lifters restrains installation | Service | Normal mode, Diagnostic mode |
| | 48028 | Impinging Lifter motor open-loop movement | Service | Normal mode, Diagnostic mode |
| Carriage Line Sensor | 55001 | Check Line Sensor | Operator,Service | Normal mode |
| | 55002 | Line sensor calibration | Service | Normal mode |
| User Interface | 80001 | Check Sensors | Operator,Service | Diagnostic mode |

Table 2-3 Diagnostic test availability 3/3 (continued)

| Subsystem | ID | Test name | Available to user | Available in boot mode |
|------------------|------------------|--------------------------------|-------------------|------------------------------|
| Scan Axis System | 86001 | Check Electronics | Operator,Service | Diagnostic mode |
| | 86002 | Check Carriage Board | Operator,Service | Diagnostic mode |
| | 86003 | Check Carriage Encoder | Operator,Service | Normal mode, Diagnostic mode |
| | 86004 | Scan-axis Test | Operator,Service | Normal mode, Diagnostic mode |
| | 86005 | Scan-axis Margin Test | Operator,Service | Normal mode, Diagnostic mode |
| | 86006 | Scan-axis Position Test | Operator,Service | Normal mode, Diagnostic mode |
| | 86007 | Scan-axis Advanced Test | Operator,Service | Normal mode, Diagnostic mode |
| | 86008 | Check Encoder Values | Operator,Service | Normal mode, Diagnostic mode |
| | 86009 | Data transmission check | Operator,Service | Diagnostic mode |
| | 86010 | Check Scan-axis Cycling | Operator,Service | Diagnostic mode |
| | 86011 | Color Calibration Coefficients | Service | Normal mode |
| | 86013 | Check Color Sensor | Operator,Service | Normal mode |
| | Printhead Primer | 88001 | Check primer | Operator,Service |
| 88002 | | Check Primer Measurements | Operator,Service | Normal mode, Diagnostic mode |
| 88003 | | Check Primer position | Operator,Service | Normal mode, Diagnostic mode |
| 88005 | | Primer Calibration | Service | Normal mode |

Table 2-3 Diagnostic test availability 3/3 (continued)

| Subsystem | ID | Test name | Available to user | Available in boot mode |
|-----------|---------------------------------|-------------------------------------------------------------------|------------------------------|------------------------------|
| Utilities | 99002 | User leading edge compensation | Service | Normal mode, Diagnostic mode |
| | 99023 | Restore All Factory Defaults | Service | Diagnostic mode |
| | 99024 | Restore All Factory Defaults Except Usage Counters | Service | Diagnostic mode |
| | 99033 | Enable advanced logging | Service | Normal mode |
| | 99034 | Enable advance debugging | Service | Normal mode, Diagnostic mode |
| | 99049 | Service Plot information | Service | Normal mode, Diagnostic mode |
| | 99055 | Set date and time | Service | Normal mode, Diagnostic mode |
| | 99056 | Set printer altitude | Service | Normal mode, Diagnostic mode |
| | 99057 | Set OOBE as done | Service | Normal mode |
| | 99058 | Restore printhead-alignment corrections to default factory values | Operator,Service | Normal mode, Diagnostic mode |
| | 99059 | Move carriage to oiler replacement position | Operator,Service | Normal mode |
| | 99060 | Move carriage to capping position | Operator,Service | Normal mode |
| | 99110 | 100L maintenance counters reset | Service | Normal mode, Diagnostic mode |
| | 99120 | 150L maintenance counters reset | Service | Normal mode, Diagnostic mode |
| | 991130 | 450L maintenance counters reset | Service | Normal mode, Diagnostic mode |
| 99140 | 900L maintenance counters reset | Service | Normal mode, Diagnostic mode | |

3 Handle the substrate

Correct handling of substrates is essential for effective, risk-free printing.

Overview

The printer can print on both rigid and flexible substrates.

The printer can work better with some substrates than others. Factors such as substrate flatness, texture or smoothness, reaction to heat, surface tension, and chemical composition can affect the print quality, the adherence of the ink to the substrate, and the overall usability for a particular application. Always test that a new substrate meets your requirements before purchasing a large quantity.

There are many different types of print substrates available throughout the world, although brands, selection, and quality will vary by region.

Supported substrate categories

There are ten substrate categories supported by HP Latex R530 series printers.

Table 3-1 Supported substrate categories

| Substrate category | Generic substrate names |
|---------------------------------|----------------------------------------------------------|
| Self-adhesive vinyl | Generic self-adhesive vinyl |
| Banner | Generic PVC banner |
| Film | Generic polyester film Generic backlit polyester film |
| Paper | Generic coated paper |
| Foam PVC | Generic PVC foam |
| Foamboard | Generic paper foamboard Generic plastic foamboard |
| Aluminum composite | Generic aluminum composite panel |
| Cardstock and corrugated carton | Coated cardstock Uncoated cardstock |
| Plastic corrugated | Generic plastic corrugated |
| Plastic solid | Generic plastic solid Generic backlit plastic solid |

Supported HP substrates

This section provides the complete information.

HP sign and display large format printing materials overview

This section provides the complete information.

The HP large format printing materials portfolio offers a wide variety of substrates developed through extensive research, design, and testing. HP offers a range of substrates in the original HP large format printing materials portfolio for sign and display applications for both indoor and outdoor applications. Available options include banners, self-adhesive materials, films, fabrics, papers, wallcoverings and specialty options. For specifications and details on the entire HP large format sign and display printing materials catalog, see HPLFMedia.com.



HP large format printers, Original HP inks and printheads, and Original HP printing materials are designed to work together as a system to provide uncompromising image quality, reliability, and consistency with every print.

Sustainability highlights

HP is committed to environmental responsibility by continuing to develop printing materials designed with the environment in mind. We offer solutions that make it easier for you and your customers to reduce your environmental impact. For a complete list of products with sustainability highlights, visit HPLFMedia.com/sustainabilityhighlights.

A wide range of HP large format printing materials products carry certifications from various third-party agencies. You can find product certifications, including approved fire certifications and more at <http://HPLFMedia.com/hp/en/certifications>.

FSC®-certified papers



Trademark license code^{*1} FSC-C115319. See <http://fsc.org>

^{*1} HP has a policy for offering Forest Stewardship Council® (FSC®)-certified papers that are sourced from FSC® certified forests and other controlled sources. BMG trademark license code FSC®-C115319, see fsc.org. HP trademark license code FSC®-C017543, see fsc.org. Not all FSC® certified products are available in all regions. For information about HP large format printing materials, please visit HPLFMedia.com.



Some recyclable HP substrates can be recycled through commonly available recycling programs. Recycling programs may not exist in your area. See <http://www.hp.com/recycle/> for more details.

Decor solutions

The demand for personalized interiors is increasing. HP large format printing materials offer limitless possibilities for creating professional and personalized customized materials for home and commercial decor. For more information, visit HPLFMedia.com/decor.

HP PVC-free Wall Paper printed with HP Latex Inks is rated A+ according to *Émissions dans l'air intérieur*, which evaluates the emission levels of volatile substances in indoor air that may pose health risks when inhaled. The rating scale ranges from A+ (very low emissions) to C (high emissions).¹

HP PVC-free Wall Paper and HP PVC-free Durable Smooth & HP PVC-free Durable Suede Wall Paper printed with HP Latex Inks are UL GREENGUARD Gold Certified.³ See <http://www.greenguard.org/>.²

HP PVC-free Wall Paper, HP PVC-free Durable Smooth, and HP PVC-free Durable Suede Wall Paper³ printed with HP Latex Inks are UL GREENGUARD Gold Certified. For details, visit www.greenguard.org.

HP PVC-free Wall Paper⁴ and HP PVC-free Durable Suede Wall Paper

HP PVC-free Durable Suede Wall Paper printed with HP Latex Inks was tested based on the test criteria of the Scheme Health-related Evaluation of Emissions of Volatile Organic Compounds (VVOC, VOC, and SVOC) from Building Products of the Committee for Health-related Evaluation of Building Products (AgBB 2018) and meets the requirements therein. See umweltbundesamt.de/sites/default/files/medien/355/dokumente/agbb_evaluation_scheme_2018.pdf.

printed with HP Latex Inks meet AgBB criteria for health-related VOC emissions in indoor building products. For more information, visit www.umweltbundesamt.de/produkte-e/bauprodukte/agbb.htm.

¹ Émissions dans l'air intérieur –mandatory labeling for decoration products in France. Provides a statement on the level of emission of volatile substances in indoor air posing health risks if inhaled—on a scale from A+ (very low-emission) to C (high-emission). Wall decorations printed with HP Latex Inks and HP PVC-free Wall Paper are rated A+ according to *Émissions dans l'air intérieur*. See developpement-durable.gouv.fr

² HP PVC-free Wall Paper printed with HP Latex Inks is UL GREENGUARD Gold Certified. UL GREENGUARD Gold Certification to UL 2818 demonstrates that products are certified to UL's GREENGUARD standards for low chemical emissions into indoor air during product usage. For more information, visit ul.com/gg or greenguard.org.

³ HP PVC-free Wall Paper printed with HP Latex Inks meets AgBB criteria for health-related evaluation of VOC emissions of indoor building products. See umweltbundesamt.de/en/topics/health/commissions-working-groups/committeefor-health-related-evaluation-of-building.

HP large format printing materials resources

This section provides the complete information.

Support Hub

HP Support Hub is a single location for technical data, assets, comprehensive guides, documentation, and other materials to help you start working with HP Large Format Printing Materials as quickly as possible. Marketing assets are also available to help you reach your customers with effective email campaigns, inform them of new product applications, educate them with instructional videos, and provide them with information about the versatile line of HP products. To access, go to: support.hplfmedia.com.

Learning Hub

The Learning Hub is home to our HP Large Format Printing Materials video training series. Each video provides a valuable overview of the HP Large Format Printing Materials portfolios. Learn about the technical specifications, features, benefits, and applications of our vast range of products. The training videos below provide information to help you, your team members, customers, and your business get the most out of these state-of-the-art products. To access, go to: HPLFMedia.com/learning-hub.

Compatibility charts

Find the correct sign and display media compatible with your printer: support.hp.com/hplfmedia.com/docs/sign--display.

ICC profiles, paper presets

Get the best performance from your HP printing system by using the correct paper preset, RIP or ICC profile for your printer and media. Go to: PrintOS - Media Locator at HPLFMedia.com/paperpresets

Media warranties

We stand behind our products. Some warranty limitations apply. For complete warranty statements, see HPLFMedia.com/mediawarranties.

Print permanence

HP designs and tests its original HP ink and large format printing materials combinations for optimal durability, realizing that different applications require different test requirements. For detailed information on image permanence and durability results for specific printing systems, see the *HP Permanence & Durability Testing Details* here: HPLFMedia.com/printpermanence.

How to store and handle substrate

Following the tips described here will help ensure the most effective lifespan and usage of substrates.

Tips

- Allow all substrates to adapt to room conditions out of the packaging for 24 hours before printing.
- Handle substrates by the edges or wear cotton gloves. Skin oils can be transferred to the substrate, leaving fingerprint marks.
- Do not stack rolls.
- Keep the substrate tightly wound on the roll throughout the loading and unloading procedures. If the roll starts to unwind, it can become difficult to handle.
- Stack rigid boards on a flat surface to prevent warping or deformation.
- When removing boards from a stack, avoid sliding them over one another to prevent surface damage.
- Store boards in a clean, cool, dust-free environment with humidity and temperature similar to the printing area. Avoid high humidity, especially with paper-based materials, as it can cause deformations during printing.

Load rigid substrate

If you see that the substrate is deformed in some way, do not try to use it.



http://www.hp.com/go/latexRseries/load_and_print_rigid

-
- ⚠ CAUTION:** Deformed substrates may get stuck in the printer and cause head crashes.
 - ⚠ CAUTION:** Under some conditions, substrates can be sensitive to heat. Before starting to print, see [Use Sensitive Mode with heat-sensitive substrates on page 234](#).
 - 📄 IMPORTANT:** The maximum thickness loadable is 50.8 mm (2 in).
-

Load a single sheet

The following steps provide the complete procedure for this topic.

1. Pull down the left lateral bar.

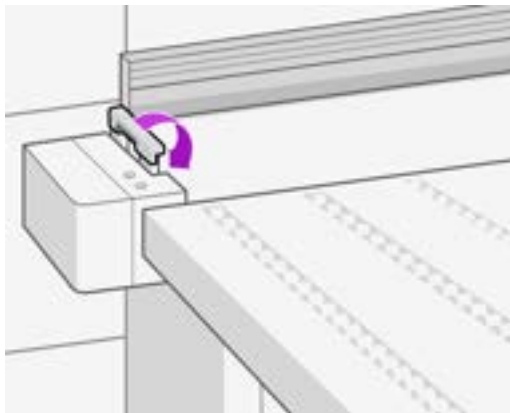
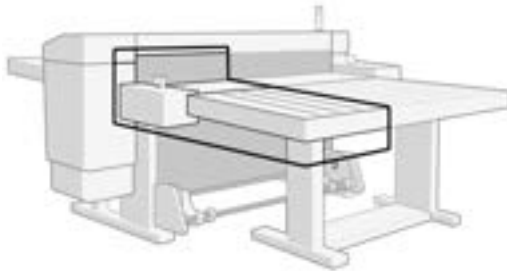

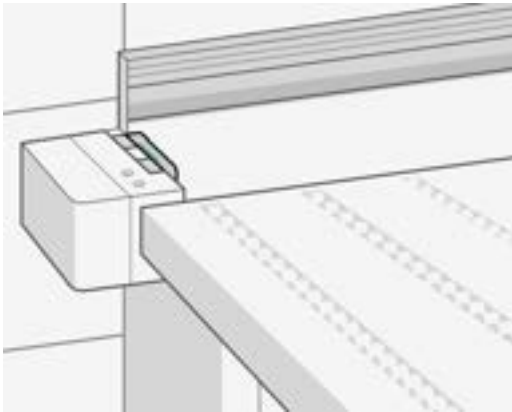

2. Place the substrate on the substrate-advance belt, and align it against the front alignment bar, then against the left lateral bar.

 **NOTE:** For best results, the alignment should be done in this order.

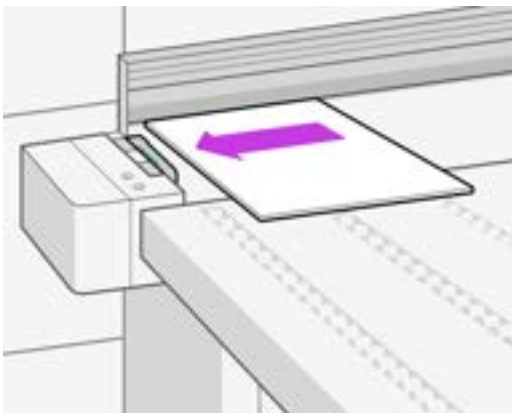
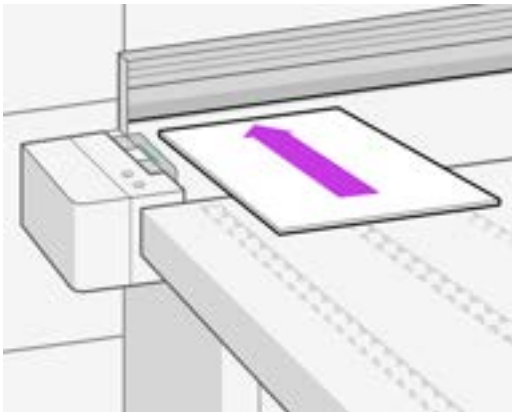

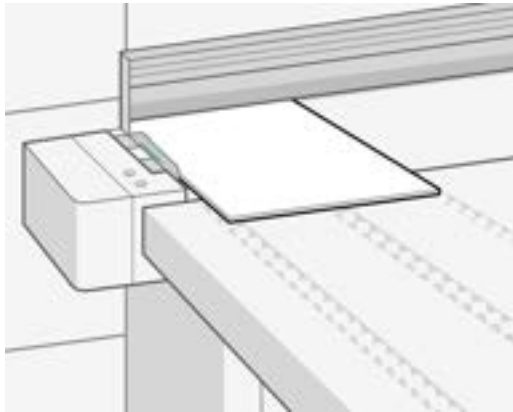

3. Remove the left lateral bar.
4. Tap the Media Load button and proceed with the loading process in the IPS.

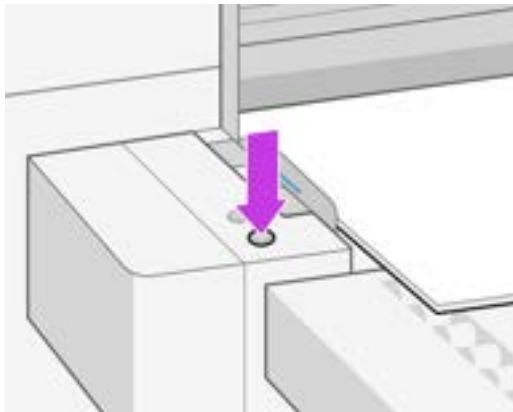

Load multiple sheets

Multiple-sheet N-up allows you to print more than one copy of a single job or multiple jobs on multiple sheets across the belt of either the same or different dimensions, using multiple rows of sheets until the job is complete.

Use the built-in substrate alignment pins for quick positioning of the sheets across the printer's width. Align the left side of each sheet with one of the pins, with a small space from the right edge of the sheet to the next pin, to allow for variations in sheet dimensions. Alternatively, if you position the pins with zero clearance between the sheets and each pin, before each print be sure to raise the pins over the thickness of the sheets; otherwise the sheets could become skewed.

 **NOTE:** This type of printing works best with an image that has wide margins on all four edges, but edge-to-edge printing is also possible by carefully matching the dimensions of the image(s) to the dimensions of the substrate sheets. Margins can be defined by the RIP or can be set and adjusted on the printer.

When loading substrate, place the number of sheets you intend to print in position to be loaded across the width of the printer. Sheets must not be more than 7.6 cm (3 in) apart from each other. Use the alignment pins if you will be printing multiple rows.

1. Pull down the left lateral bar.

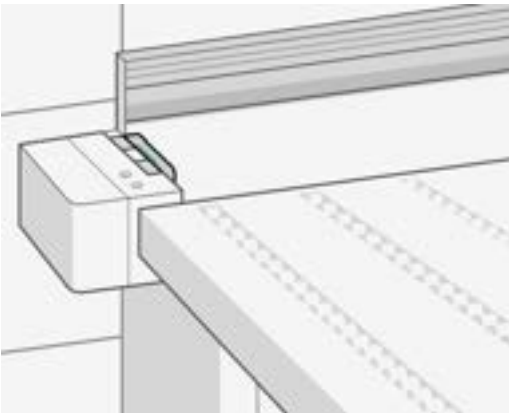
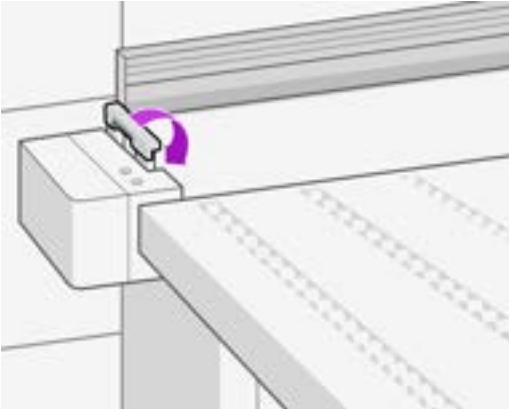
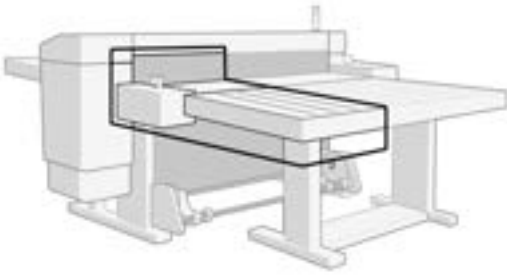

2. Place the substrate on the substrate-advance belt, and align it against the front alignment bar, then against the left lateral bar.

 **NOTE:** For best results, the alignment should be done in this order.

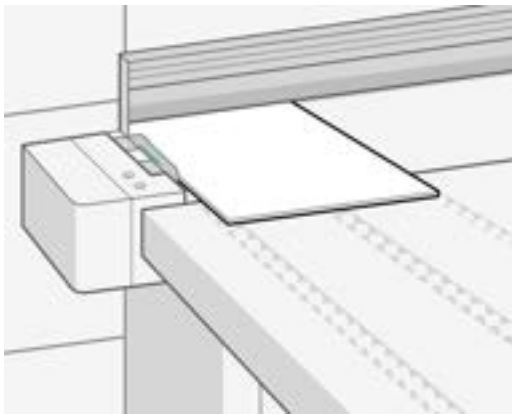
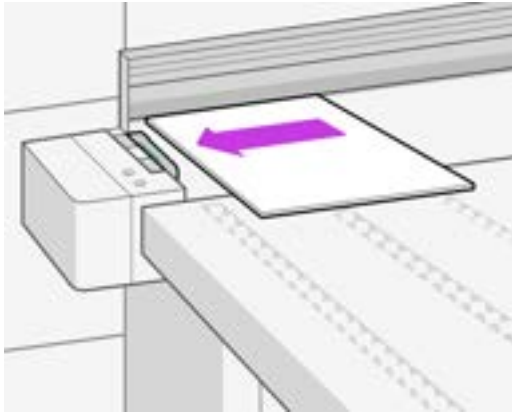
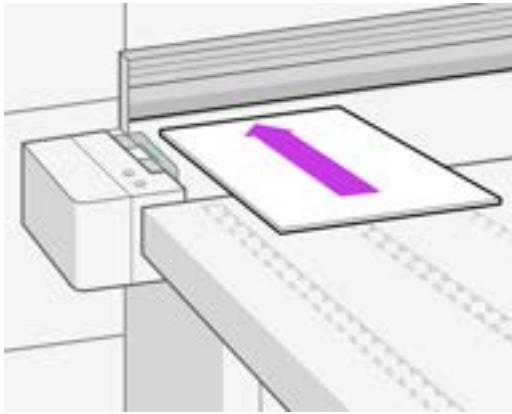

3. Locate the closest pin, squeeze the grip, and slide the pin to the position at which the left edge of the next sheet will be placed.

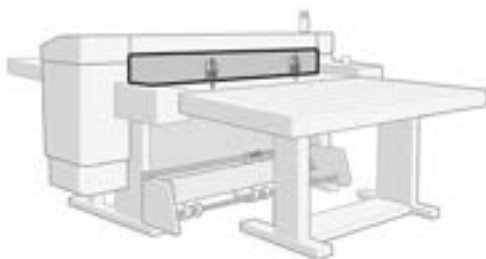

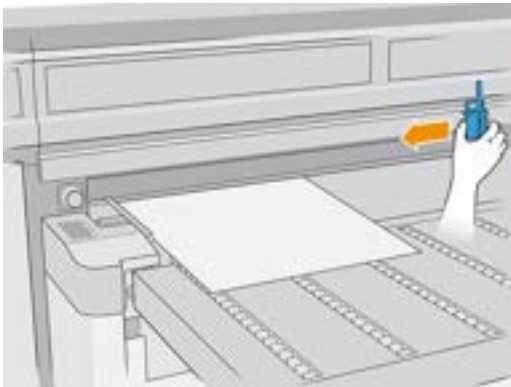
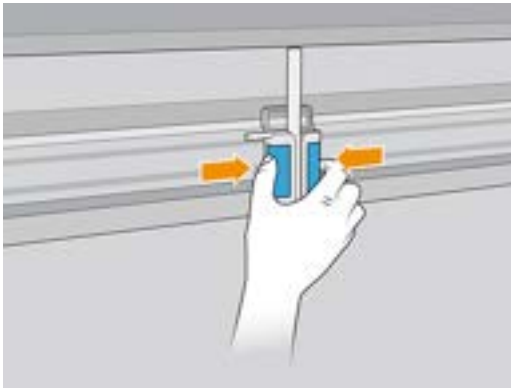

4. Rotate the pin handle and pull it down.

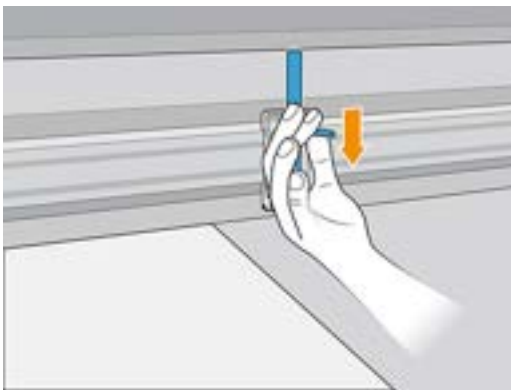

5. Place the next sheet on the substrate-advance belt, and align it against the front alignment bar and the pin.

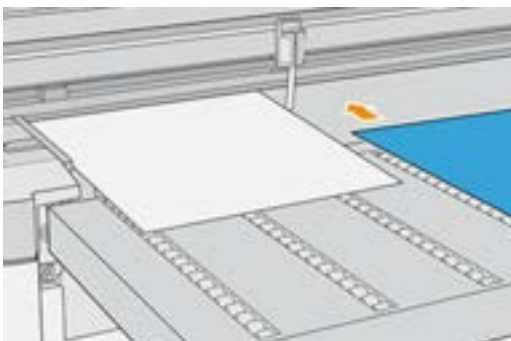

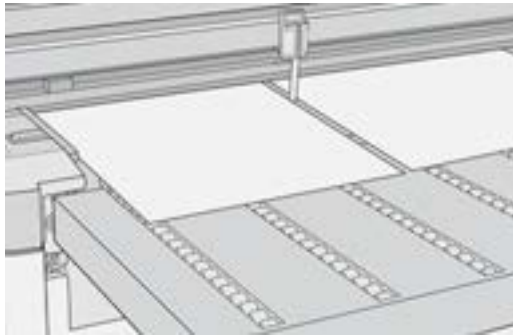
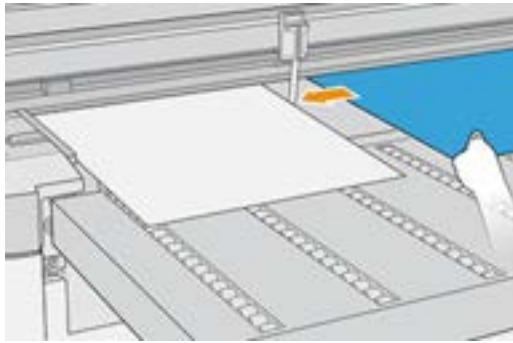

6. Repeat the above steps for as many sheets as you want to load.
7. Remove the lateral bar.
8. Tap the Media Load button and proceed with the loading process in the IPS.

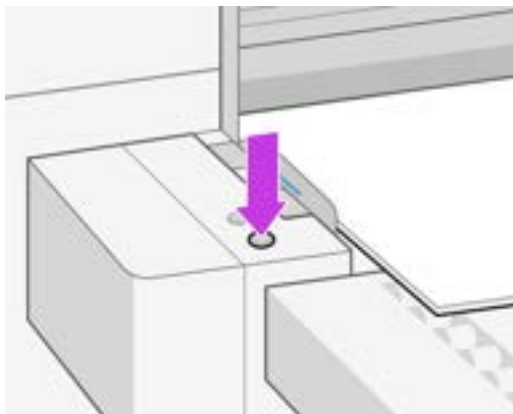

Multi-sheet printing (same dimensions)

Multiple copies of a **single image** can be made by setting the quantity to a number equal to or greater than the number of the sheets you loaded. The printer prompts you to load more sheets until the number of copies you specified has been printed. You can print any number of copies in this configuration, even if the total number does not divide evenly into the number of sheets per row. Only the last row may have a different number of sheets.

The **Multi-image** feature is enabled by selecting the **Print 2-sided / Multi-image N-up** button in the lower right corner of the **Stored Jobs** screen, then selecting **Multi-image N-up** in the following screen. Each of the jobs across the belt can be different jobs, but all jobs must have the same color set and resolution. Once the first job is selected, the printer displays jobs with a color set or resolution mismatch with a red border. If a different print mode is desired, or if separate jobs have different print modes but share

the same resolution, a single print mode is changeable by selecting **Print mode** in the summary screen. Enter the number of image groups or 'rows' to be printed and tap **Proceed**.

Multi-sheet printing (different dimensions)

As with multi-sheet printing with the same dimensions, multiple copies of a **single image** can be made by setting the quantity to a number equal to or greater than the number of the sheets you loaded. Because sheets can be of different sizes, and the image of a single size, be careful about job alignment and overprinting onto the belt.

Again, as with multi-sheet printing with the same dimensions, the **Multi-Image** feature is selected from the **Stored Jobs** screen, following the same process. Because sheets can be of different sizes, and the images of various sizes, be careful about job size and alignment when selecting jobs.

How to load rigid media with special register requirements

This section provides the complete information.

Belt forward / reverse

Continuous reverse movement of the belt can cause instability, affecting image registration on the sheet. This typically occurs during rewinding after printing on flexible materials.

To maintain consistent image registration, it is recommended to perform a long forward movement of the belt. Use the IPS to move the belt forward by 10,000 mm.

 **NOTE:** Belt destabilization does not affect the IQ, as it readjusts very slowly.

 **NOTE:** Small reverse movements during material loading with AutoMeasure do not destabilize the belt.

Full bleed recommendations

When printing on pre-cut sheets where the image reaches the edge of the material, it is recommended to print an image slightly larger than the sheet and activate the **Full Bleed** option: **IPS Image**.

This option automatically centers the image along both axes and allows the printable area to extend beyond the sheet.

Recommended image oversize:

- Sheets < 1000 mm long: Add 3 mm on each side
- Sheets > 1000 mm long: Add 5 mm on each side

These extra 3 or 5 mm will print onto the belt but ensure no unprinted edges are visible. For example, for a 500 × 1000 mm sheet, set the image size to 506 × 1006 mm.

Dual-side loading workflow.

When performing hot loading (measuring only the first row), the recommended approach for dual-side printing is to adjust the board alignment based on the side to be printed.

Recommendation for a single board

Side A

- **Image alignment**
 - Center in SAX direction
 - Center in the Madv direction (use a length of 1000 mm)
- **Board alignment**
 - SVS side.

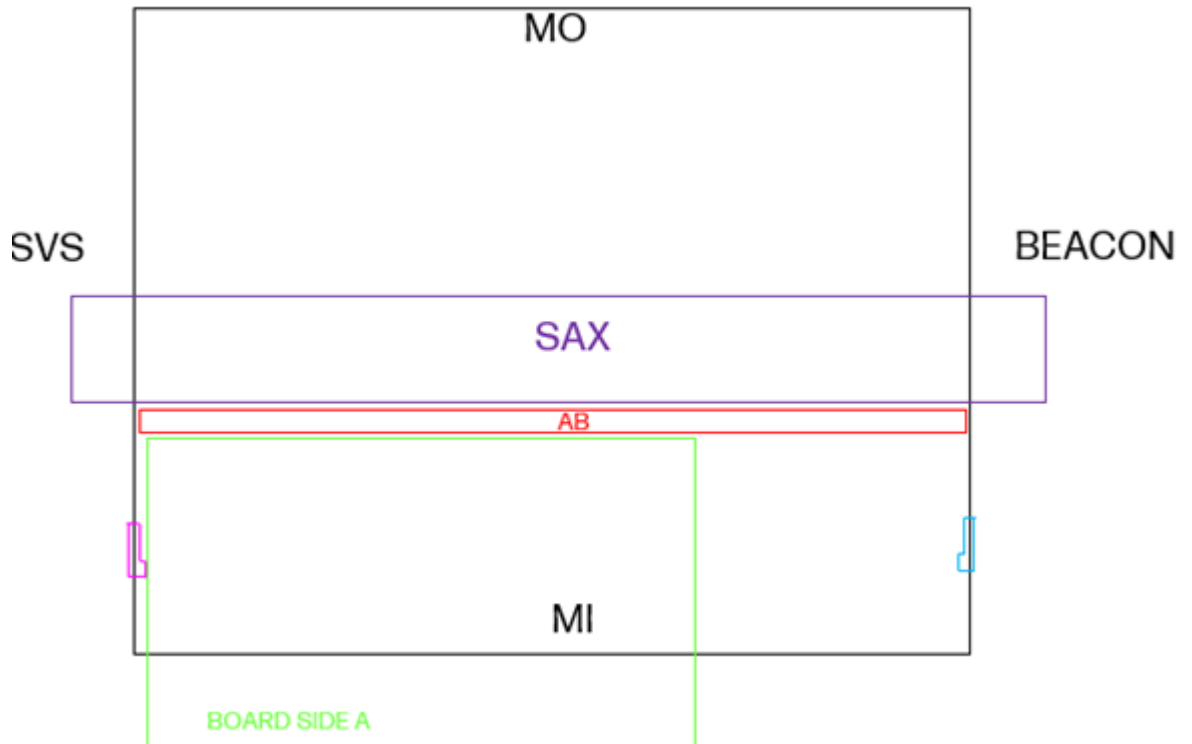

Side B

- **Image alignment**
 - Center in SAX direction
 - Center in the Madv direction (use a length of 1000 mm)
- **Board alignment**
 - Beacon side

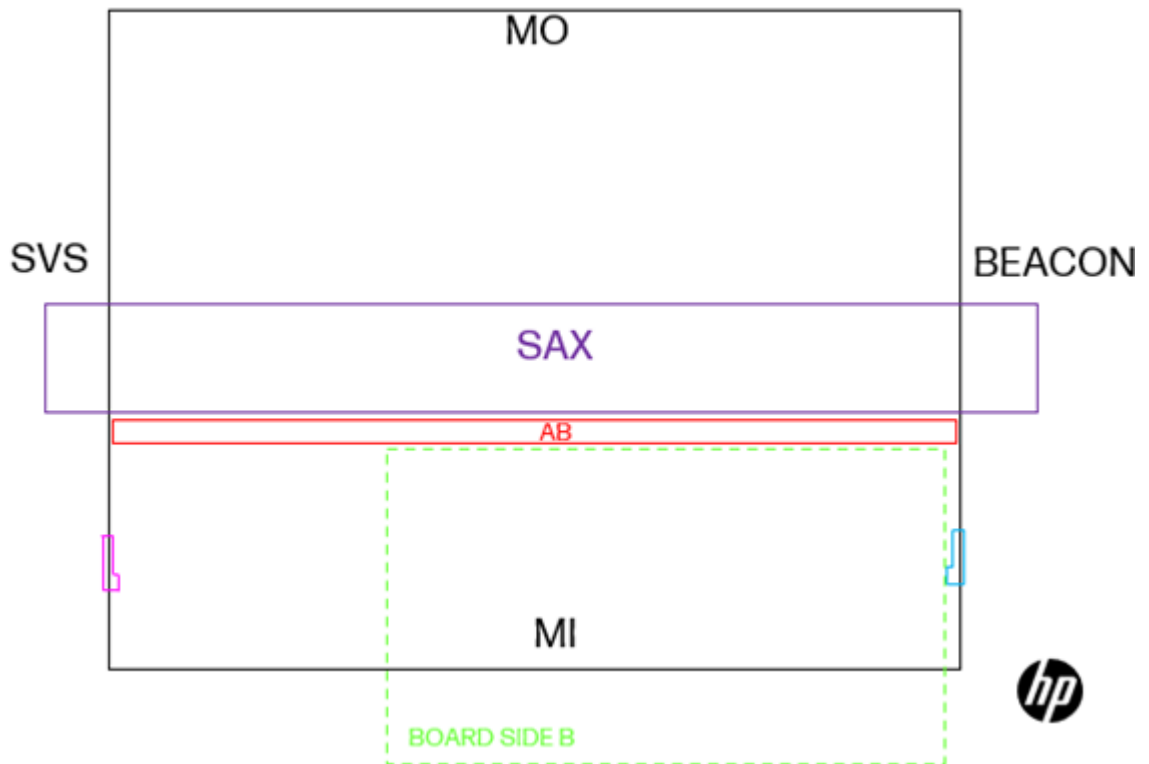

Recommendation for two boards

Side A

- **Image alignment**
 - Center in SAX direction
 - Center in the Madv direction (use a length of 500 mm)
- **Board alignment**
 - Board 1: SVS side
 - Board 2: Beacon side

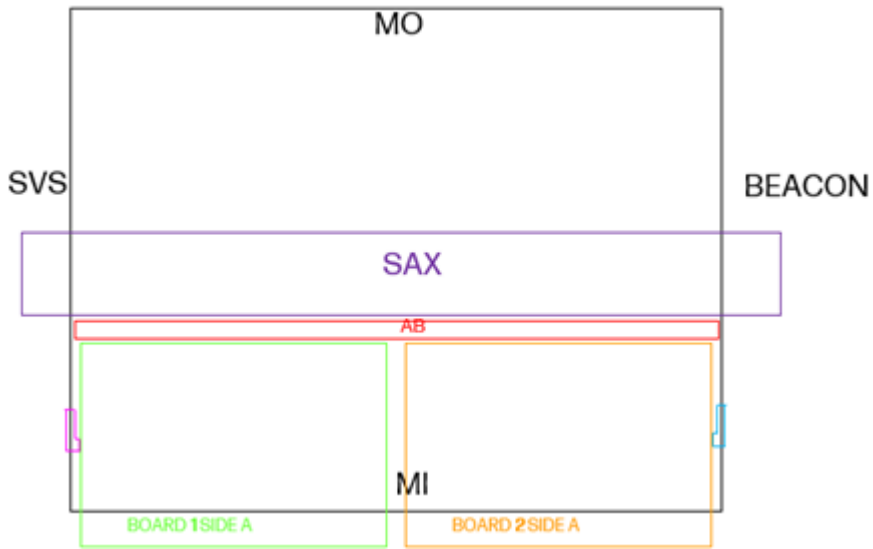

Side B

- **Image alignment**
 - Center in SAX direction
 - Center in the Madv direction (use a length of 500 mm)
- **Board alignment**
 - Board 1: Beacon side
 - Board 2: SVS side

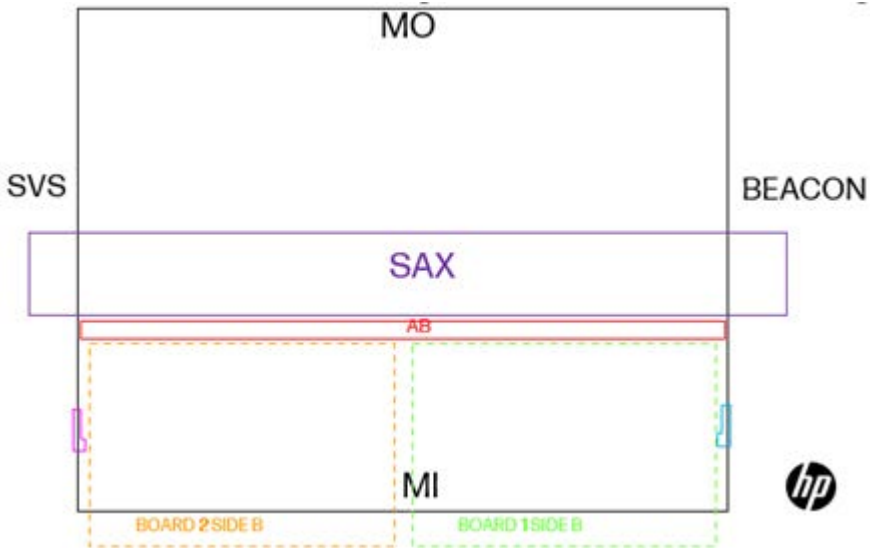

Recommendation for multiple boards

Side A

- **Image alignment**

- Center in SAX direction
- Center in the Madv direction (use a length of 750 mm)
- **Board alignment**
 - Board 1: SVS side
 - Board 2: Middle with N'UP
 - Board 3: Beacon side

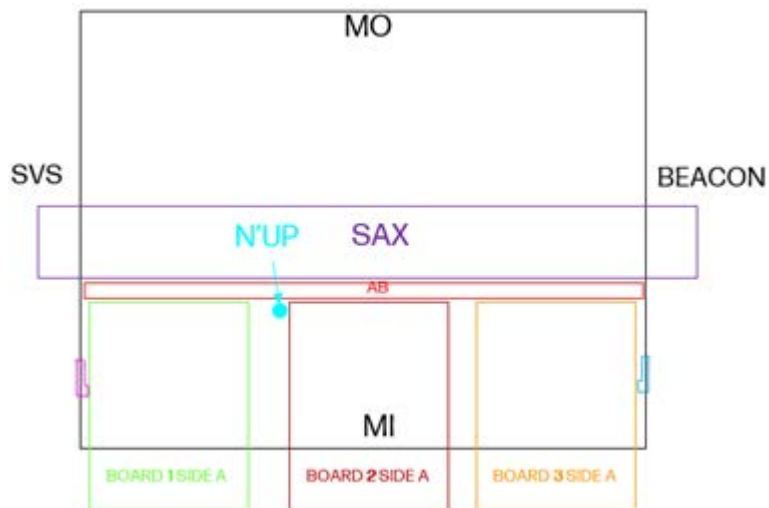

Side B

- **Image alignment**
 - Center in SAX direction
 - Center in the Madv direction (use a length of 7500 mm)
- **Board alignment**
 - Board 1: Beacon side
 - Board 2: Middle with N'UP (remember to change sides)
 - Board 3: SVS side

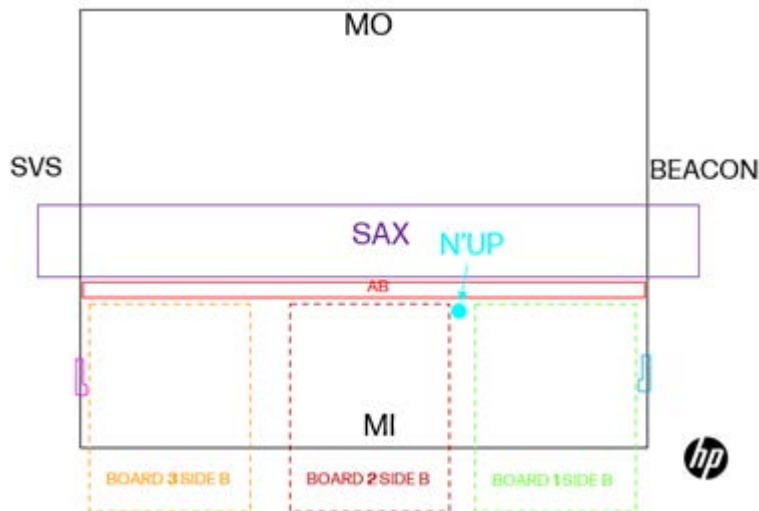

Load a roll into the printer with buttons

The following steps provide the complete procedure for this topic.

The objective when loading substrate is to achieve a uniform tension across its width and length to minimize the risk of skew, wrinkles, and telescoping.

The substrate roll is mounted on the Media Input and can be left to fall freely to the floor or collected on the take-up reel (Media output). Each side has its own motor that maintains tension on the substrate. A vacuum is applied to the belt to ensure that the substrate remains flat. The substrate is moved forwards by the drive roller motor, while the vacuum on the belt prevents the substrate from slipping.

1. Put the roll onto the table and insert it onto the left-hand hub.

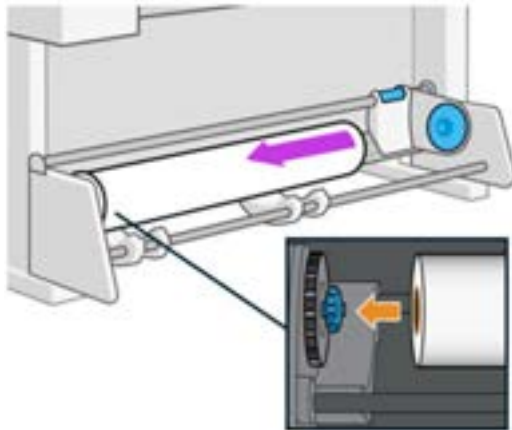

2. Lift the right-hand side of the roll and insert the right-hand hub into position. Press to ensure that it is firmly inserted.



3. Pull the lateral bar up.

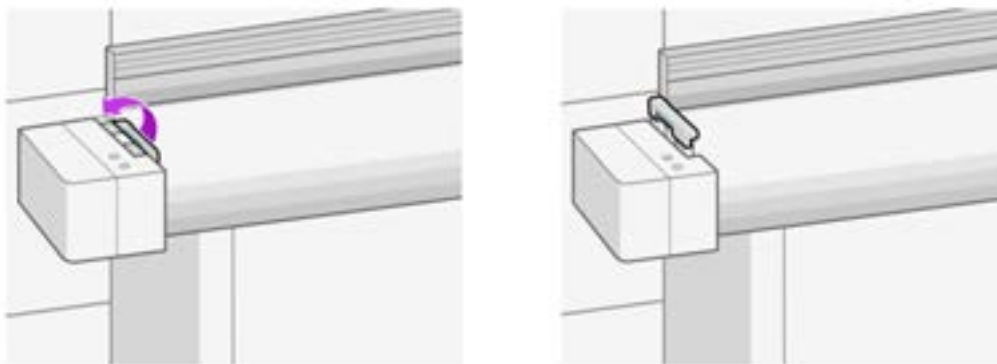

4. Push the button on the Media Load control to select the roll. The white LED will start to blink for a few moments.



5. Unroll a short length of substrate.

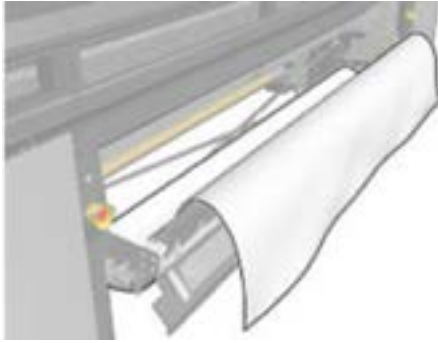

6. Place it on top of the substrate-advance belt with the leading edge of the substrate under the front alignment bar

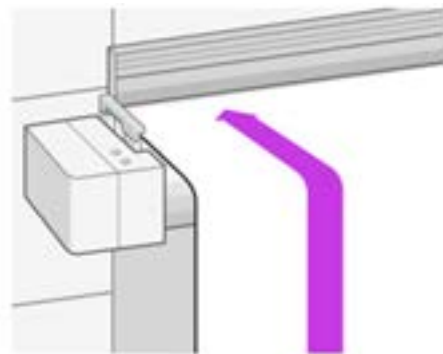
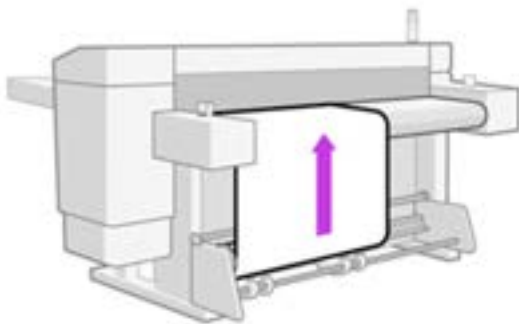

7. When the white LED around the Media Load button is ON, push it.

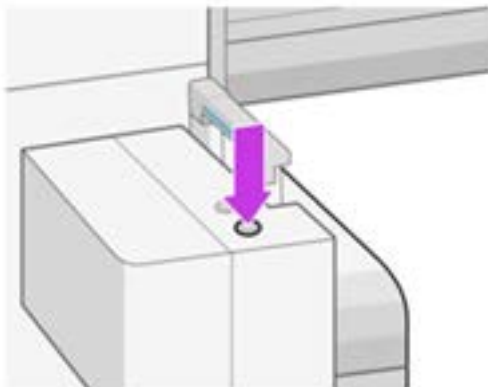



8. Go to the Internal Print Server and follow the instructions to complete the load process.

 **NOTE:** Some substrates (such as transparent and dark substrates) cannot be measured by the printer in this way. In such cases, you will be asked to enter the Left Edge and Width fields manually into the Internal Print Server.

9. When the printer is ready, if you agree with the information shown by the Internal Print Server, tap Done.

The printer is now ready to print.

- Allow the substrate to fall freely to the floor.
- Collect the substrate on the collector.

Take-up reel

The take-up reel (TUR) collects the substrate as it emerges from the printer.

Attaching the media to the TUR can be completed with two methods:

- Advancing the material to the TUR and attach it.
- Print on the fly by starting from the pinch rollers and attaching the media to the TUR once the leading edge reaches it.



Load a roll onto the take-up reel

The take-up reel is enabled by turning the output roll one full turn in the desired direction of winding.

1. Load an empty core onto the take-up reel, matching the size of the printer media. Insert it onto the right hub first.

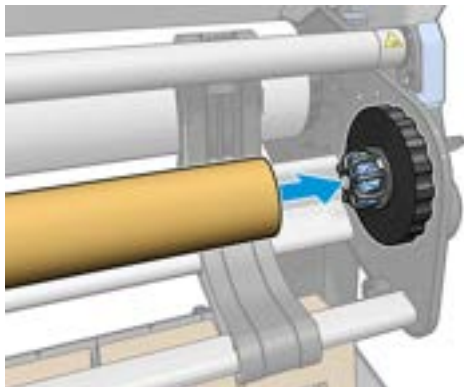

2. Insert the left hub into the core. Press laterally to ensure that it is tightly inserted.
 - Raise the brake lever so that the hub does not move.



3. Advance the substrate or wait until the leading edge reaches the take-up reel core.



4. Cut the leading edge in "V" shape and pull down the center to straighten the substrate. Do not attempt to pull more substrate out of the printer.

5. Tape the leading edge of the substrate to the core in the center. Make sure that the substrate is straight.



 **NOTE:** Depending on whether you want to print the images facing in or out, place the tape accordingly.

6. Rotate the right hub disc a quarter revolution to trigger printer detection.
 - If printing is in progress, wait until a small media buffer forms before turning the hub or activate the TUR from the IPS.
 - If attaching the media before printing, advance it by 100 mm to create a buffer, then turn the hub a quarter revolution or activate the TUR from the IPS.

 **NOTE:** The normal mode of operation of the take-up reel when printing is to collect the substrate and, once it is tensioned, release some substrate back to provide optimal advance accuracy.

Unload the take-up reel

Before unloading the take-up reel, the substrate must be safely cut.

1. Move the substrate forward by 1200 mm and deactivate the TUR from the IPS.
2. Cut the substrate in the area between the belt and the TUR.

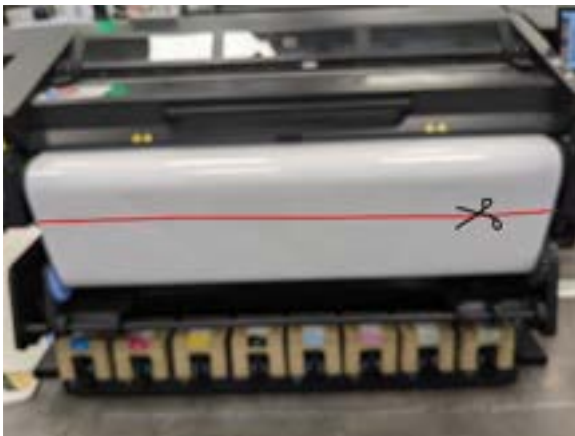

 **CAUTION:** Take care not to damage the substrate-advance belt when cutting the substrate.

3. While holding the substrate, turn the right-hub disc on the take-up reel to wind the remainder of the substrate around the take-up reel.

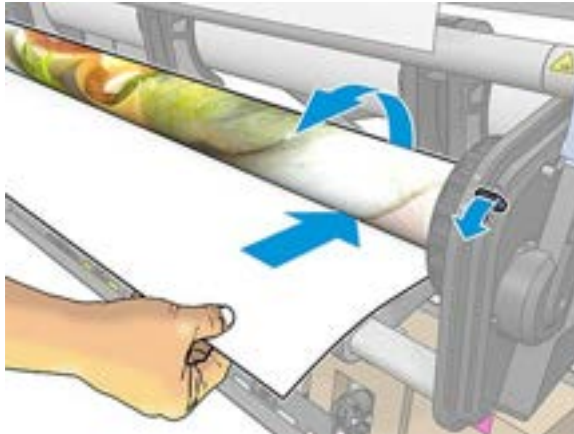

4. Lower the brake lever and remove the left hub from the roll.
5. Remove the roll from the right hub.

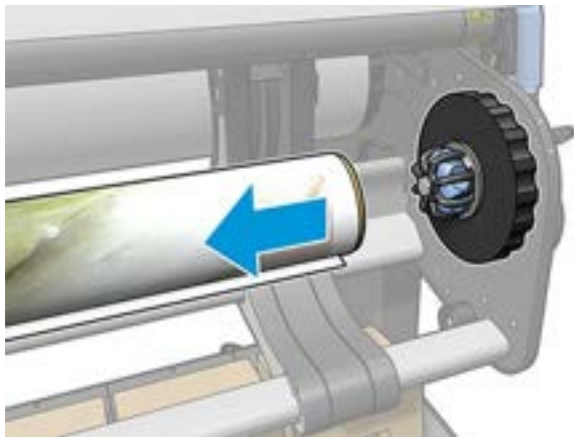

6. Remove the roll from the printer.

How to load the take-up reel for tiling applications

Loading the take-up reel correctly is crucial to achieve the best performance for tiling applications.

1. Perform the steps in [Load a roll into the printer with buttons on page 55](#).
2. Once media is loaded, ensure the hold down plate is installed.
3. Ensure the media is taut and without wrinkle.
4. The printer achieves good tile repeatability when printing from the pinch, where the substrate's leading edge is positioned after loading the media.
5. To maximize tile repeatability, advance the leading edge to the end of the belt or attach it to the TUR.

Unload the media

Perform the steps to unload the media from the printer.

1. Unload the media from the TUR. For more information, see [Unload the take-up reel on page 60](#).
2. In the IPS, retract the media 2000 mm.
3. Take the leading edge at the printer's input and hold it until the media input rewinds the roll.
4. Remove the right hub from the roll.

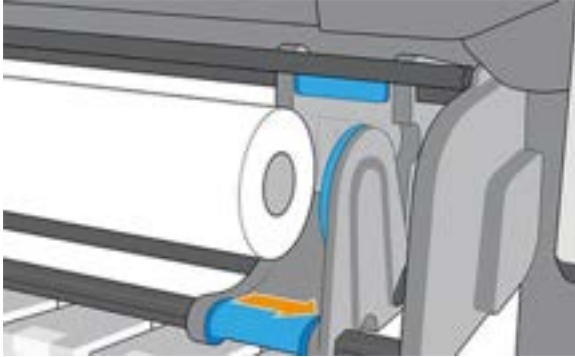

5. Remove the roll from the left hub.

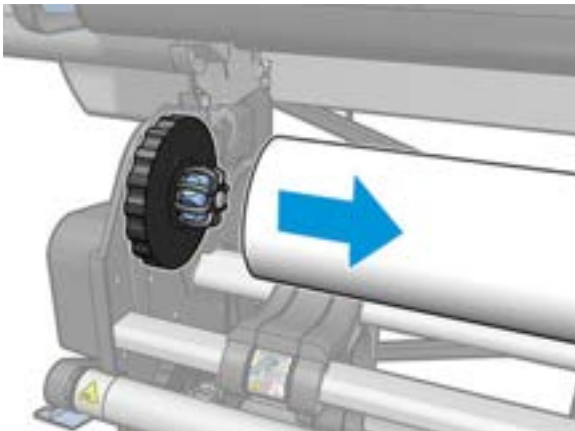

6. Remove the substrate from the printer.

Unload a roll from the printer

Follow these steps to correctly unload a substrate roll into the printer.

-
-  **TIP:** HP recommends not leaving the substrate loaded when the printer will not be in use for a long period of time, such as overnight or at weekends. Substrate left loaded may become deformed, causing problems such as printhead crashes.
-

1. If you used the take-up reel during printing, unload the printed roll from the take-up reel. See [Unload the take-up reel on page 60](#).

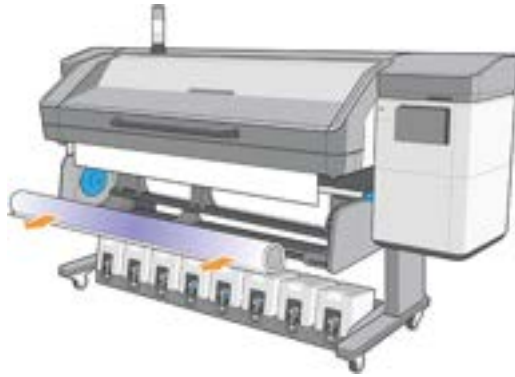

2. 800 series only: Rotate the pivot system so that the input roll is accessible.



3. On the printer's control panel, tap , then **Unload**.

Alternatively, you can tap , then **Substrate > Unload substrate**.

4. If the printer has been tracking the length of the substrate, the control panel displays the remaining length so that you can note it for future reference. See [Substrate length tracking on page 76](#).

Tap **OK** to continue.

5. When the printer has rewound the roll, remove the left hub from the roll.

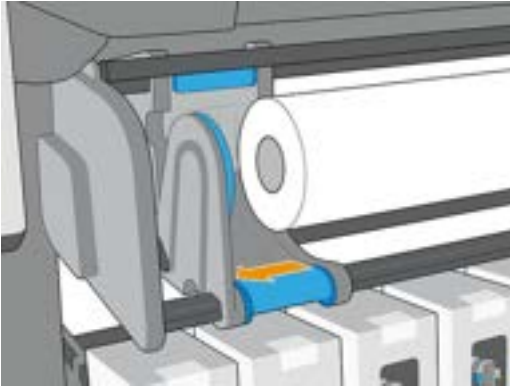

6. Remove the roll from the right hub.

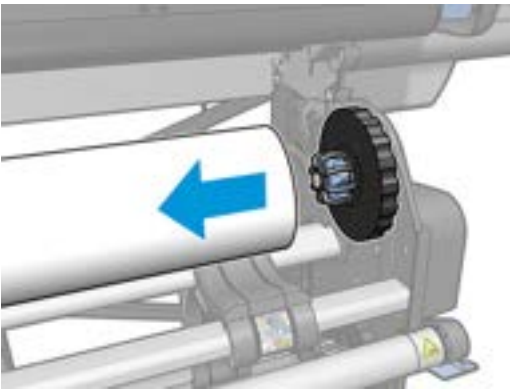

7. Remove the substrate from the loading table.



IMPORTANT: If you reach the end of the roll and the substrate becomes detached from the core:

- Print-quality issues may occur on the last few centimeters of the substrate due to lack of tension.
- The tape or glue at the end of the substrate may stick to the curing mechanism.
- If the printer goes into sleep mode with the core detached, then when waking up it will be as if there is no substrate, and a printhead crash may occur.

When lifting the pinchwheels to unload the substrate, avoid pulling the substrate out through the print zone, which could leave the tape or glue at the end of the substrate stuck behind the pinchwheels.

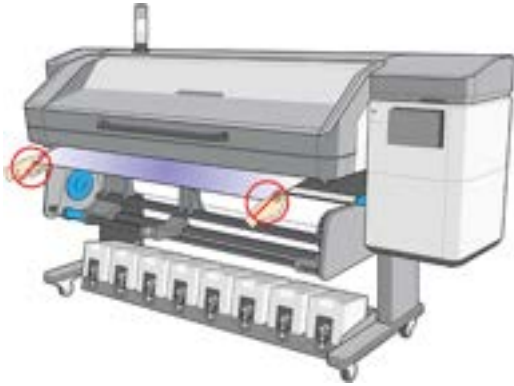

Hold-down plate

Wrinkles in the substrate can cause printhead crashes. The hold-down plate is a device to prevent such wrinkles from entering the print zone.

The occurrence of wrinkles may vary from one roll to another; they can be caused by the manufacturing process or the bagginess of the substrate.



HP recommends using the hold-down plate for the following media types.

How to use the hold-down plate

The following steps provide the complete procedure for this topic.

You must keep the hold-down plate above the central top cover of the printer.

1. Load the substrate.



2. Lift up the lateral bars on both sides.

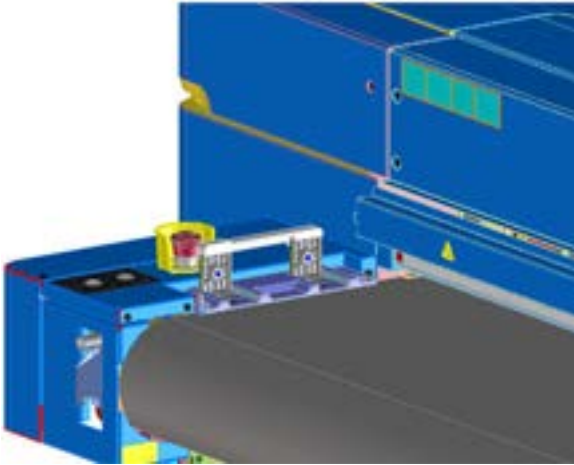

3. Put the hold-down plate over the substrate.



4. Ensure that the pins fit into the holes at the edges of the brackets.

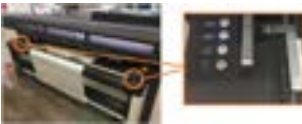

5. Print as usual.



Maintenance tasks

The following sections provide details for this topic.

Velvet replacement

The following steps provide the complete procedure for this topic.

After some use, the hold-down plate velvet may become damaged or worn, possibly leaving marks on the printed side of the substrate.

1. Place the hold-down plate on a flat surface.



2. Remove one of the side brackets, using a T20 screwdriver.



3. Remove the black slot covers that fix the velvet to the beam.

 **TIP:** You can use a flat screwdriver for this operation.



4. Remove the velvet from the beam.



5. Remove both rods from the velvet.

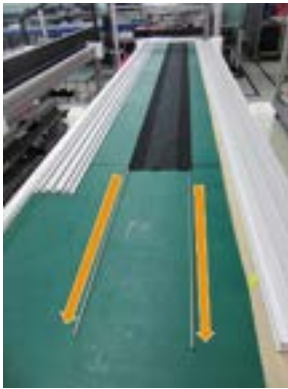

6. Insert the rods into the new velvet.



7. Place the new velvet with the rods inside the beam slots.



8. Insert the black slot covers into the first slot.

9. Insert the black slot covers into the second slot, ensuring that the velvet remains flat under the beam.



10. Reinstall the bracket that you removed earlier.

Fabric replacement

The following steps provide the complete procedure for this topic.

 **NOTE:** After some use, the fabric of the hold-down plate may become damaged or worn, possibly leaving marks on the printed side of the substrate.

1. Place the hold-down plate on a flat surface.

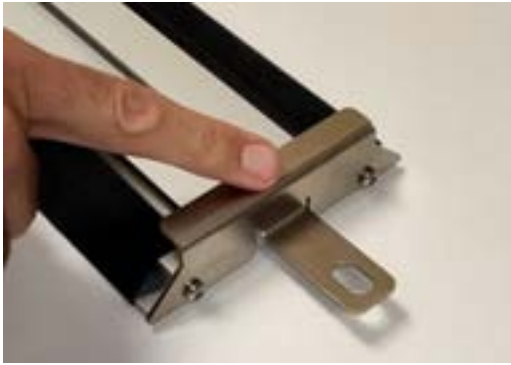

2. Remove the two side brackets, using a T20 screwdriver.



3. Remove the two metal rods.

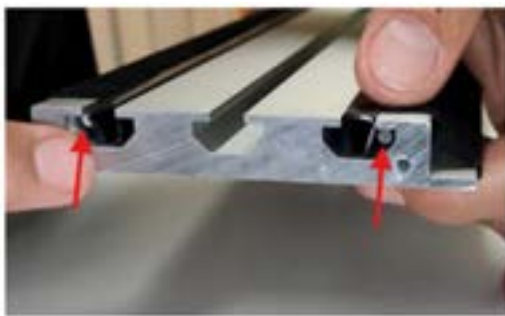



4. Remove the two black slot covers that fix the Fabric to the beam.

⚙️ **TIP:** You can use a flat screwdriver for this operation.



5. Remove the Fabric from the beam.

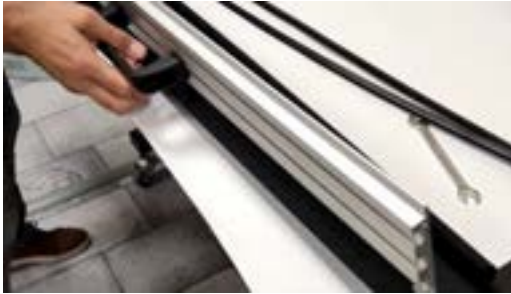

6. Place the new Fabric on a flat surface and put the beam on top aligning both edges.



7. Insert the two black slot covers to fix the Fabric to the beam.

 **NOTE:** Ensure there is no wrinkles before fixing the Fabric.



8. Insert the two metal rods.

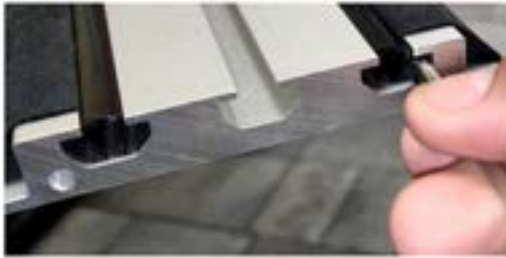

9. Reinstall the two brackets.



Lateral bracket replacement

The lateral brackets can become damaged during manipulation. In case of deformation of the bracket, it can be easily replaced by a new part using a T20 screwdriver.



Substrate tips

The following sections provide details for this topic.

Flexible substrate handling guidelines

Handle film and glossy substrates by the edges or wear cotton gloves. Skin oils can be transferred to the substrate, leaving fingerprint marks.

Keep the substrate tightly wound on the roll throughout the loading and unloading procedures. If the roll starts to unwind, it can become difficult to handle.

In the case of a roll, check that the substrate is correctly attached to the input core. Otherwise, the Internal Print Server will report an error.

It is recommended to load the media with a clean, straight cut in the leading edge. Do not overfeed the media under the alignment bar; a few millimeters is acceptable, but more than 100 mm could create crashes since the leading edge will not be held by the vacuum.

 **IMPORTANT:** Never attach the leading or side edge to the belt with tape or similar when using media from a roll. Beginning of job deskew could break rewinder components.

Install the hold-down plate after the loading workflow is finished for all media to avoid wrinkles.

Rigid substrate handling guidelines

Store substrates flat in a clean environment with the same or similar temperature and humidity as in the printer room.

Never use a sheet of substrate that exceeds 68 kg (150 lb) in weight.

To reduce the risk of damage due to a head strike, do not print on a sheet longer than the tables are designed to support. Optional extension tables are available for longer sheets.

Tables should be leveled so that the tops of the table rollers are level and coplanar with the flat surface of the substrate belt.

Ensure that the tables are latched securely to the printer to establish a proper grounding path for any residual static that may build up on the substrate.

Generic substrate settings may need to be adjusted when using substrates that deform under sustained heat. These cases may require a lower temperature, reduced ink density, a higher vacuum setting, a higher-than-standard head height, or the use of an output roller to achieve the best results.

For best results, sheets should have parallel opposite edges with 90° corners. Non-rectangular sheets will require extra attention when loading.

Both sides of the substrate should be clean and dry.

Some substrates may have a surface coating that can cause ink to pool and cure unevenly, resulting in poor print quality. Test coated substrates for compatibility before purchasing significant quantities.

Avoid substrates with bent or damaged edges, especially metal composite and corrugated substrates, as they can cause head crashes, drag, or vacuum loss, leading to substrate feed errors or skew.

Some substrates may have thickness variations within the same sheet, which can cause print-quality issues or head strikes. When loading substrates with possible thickness differences, such as acrylic cast sheets or natural woods, measure the sheet thickness at different points and manually enter the highest measured value.

For best results, individual sheets should be flat. Curves in either axis (left to right or front to back) can lead to head strikes. Non-flat substrates can also affect dot placement accuracy and overall feed accuracy. The printer handles convex deformations better than concave ones.

For difficult materials where side edges may deform under heat, the media edge pinch wheels can be used. For plastic solids, they work best with media thicker than 2 mm and are not effective for thinner materials. When using them, activate them on the screen and ensure they do not step on the printed area, as the ink will not yet be dry.

Static electricity

Static electricity is often a problem when working with rigid synthetic substrates. These substrates are often non-conductive, so static charges cannot dissipate on their own. Besides minor personal discomfort from static shocks, static attracts foreign particles to the substrate that prevent ink from adhering to the surface. Static can also attract ink droplets to areas of the surface that were supposed to remain unprinted. Low humidity levels in the printer and substrate storage environment can exacerbate the issue.

A number of active and passive methods can be employed to minimize static:

- Maintain a relative humidity level of 40–60% in both the printer and substrate storage areas.
- Drape a conductive material such as copper tinsel over the stacks of substrate and attach it to a grounding point. This will help to discharge the static from each sheet as it is removed from the stack.
- Wipe down the substrate surface prior to printing with a general-purpose industrial cleaner (such as Simple Green). This will remove any foreign particles that were attracted to the substrate by static.
- For extreme static problems, careful use of an antistatic spray may be warranted. Lightly spray on, not allowing it to pool on the substrate. Note that the ink-adhesion properties of some substrates may be negatively affected by the spray, so use the minimum amount necessary to achieve results. Adhesion decreases approximately 10%; this typically occurs on substrates that already had poor adhesion properties without the spray.

Automatic measurements

If automatic measurements are enabled, the printer automatically measures the substrate once it has been loaded.

- Width

- Thickness
- Skew

Substrate length tracking

The substrate length tracking feature enables you to keep track of how much substrate remains on the roll.

1. When the roll is first loaded onto the printer, you have the option (in the Load Configuration screen) to enter the length of substrate on the roll. The amount of substrate that is subsequently used is then tracked.
2. When the substrate is unloaded, the control panel displays the amount remaining so that you can note it for future reference.

Substrate configuration

Various parameters can be changed in the **Substrate** window.



Substrate parameters

This topic explains the concepts involved in this subject.

When loading substrate, the following parameters can be chosen:

- Substrate type
- Auto-measure

These measurements are used only if automatic measurement is not activated.

- Position
- Width
- Skew
- Thickness

 **IMPORTANT:** The length of a rigid substrate is never measured automatically; you must always enter it manually.

- Sheets per row, for multisheet printing only (see [Load multiple sheets on page 45](#)).

Substrate type dialog

In the **Substrate type** dialog box, you choose a substrate type.

You can choose from a list of rigid substrates. If you have the roll printing kit installed, you can also choose flexible substrates.



Tap a substrate name to select it.

Automatic measurements

This topic explains the concepts involved in this subject.

If automatic measurements are enabled, the printer automatically measures the substrate once it has been loaded. The following characteristics are measured:

- Width
- Thickness
- Skew

Substrate status

The substrate status is displayed in the print preview.

To print more than one sheet in a row, you can use N-up printing. See [Load multiple sheets on page 45](#).

- **Loaded:** When the selected substrate configuration corresponds to the one that is physically loaded in the printer.



Substrate dimensions

The substrate dimensions can be changed within the substrate dialog.

IMPORTANT: When loading a rigid substrate, you should always enter its length manually.



Job properties

From the Internal Print Server's main window, double-tap the print queue to open the Job Properties window.

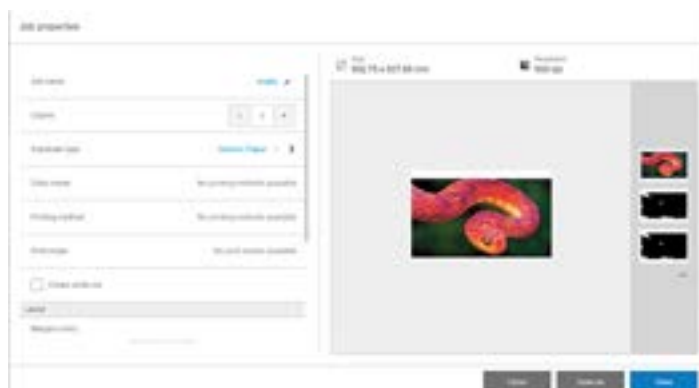

Use the **Save As** button to create a copy of an existing job with a different name.

This dialog has the following basic options:

- **Copies**
- **White mode:** Visible only when **Color + white** is selected
- **Print mode**
- **Choke**
- **Margins:** Left, right, top, bottom
- **Alignment:** Left, center, right

Margins, alignment, and number of copies can also be selected to the right of the preview area.

Although the substrate and print mode can be changed from this dialog window by using the change button, HP recommends not to do so because it may adversely affect print quality. It is better to change the substrate and the print mode from the RIP.

 **NOTE:** The Internal Print Server gives you a warning if you select layout changes that are not compatible with your selections in the RIP.

How to print (overview)

The three steps described here provide a simple overview of the printing process.

1. Load the substrate. The printheads are automatically aligned.
2. Perform color calibration.
3. Send a job to the printer.

4 Substrate settings

Maintaining appropriate substrate settings is essential for effective printing.

Substrate presets

To obtain the best print quality, the printer has to adapt its printing parameters to each different substrate type.

Each substrate type has its own characteristics. For example, some may need more ink and some may require higher temperatures for curing. A specification of the correct printing parameters for a particular substrate type is called a substrate preset.

The substrate preset contains a color profile in International Color Consortium (ICC) format, which describes the color characteristics of the combination of printer, inks, and substrate. It also contains information about other parameters (such as curing temperature, vacuum pressure, and overcoat level) that are not directly related to color. Substrate presets (also known as Open Media System or OMES packages) can be installed in the printer, and automatically copied to supported RIP software whenever it is connected to the printer.

The printer includes default presets for the media categories. These presets, named Generic, are recommended for initial printing. Generic presets are designed to be robust and adaptable across various substrates within the same media category. This ensures that most substrates are compatible with the generic preset. Note that generic substrate settings cannot be modified; however, you can clone a preset and modify it. Running the CLC is also recommended to maintain consistent color throughout the printer's lifespan.

You can check whether your substrate is recommended for a generic preset or requires a specific preset in the following ways:

- Use the online search function on the control panel or the HP Media Locator on the web to browse and check if your substrate needs a specific preset or if the generic preset is recommended. If a specific preset is required, download it for your printer.
- In the Configuration Center, you can view substrate presets from your printers, the HP Media Locator, and your reseller in one place and deploy them to your printers.
- Create a new preset by using another profile as a base.

If you can find a ready-made preset for your specific substrate, you are recommended to use it.

Generic presets

Generic presets are each designed for a whole substrate category, rather than for a particular substrate type. They cannot be edited, erased, saved, color-calibrated or ICC profiled; but they can be cloned. Therefore, you must clone a generic preset in order to be able to color-calibrate the substrate, or to modify any other property.

Generic Presets are designed to be robust and versatile, ensuring compatibility with most substrates within the same media category.

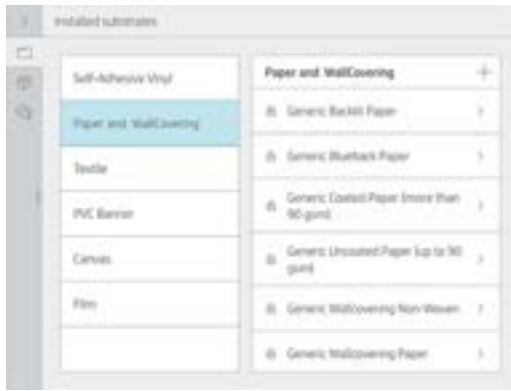

In addition, you always need to clone from a generic preset in order to perform calibrations, even if you don't want to change any setting.

The printer provides generic presets for the supported substrate categories: see [Supported substrate categories on page 39](#).

Use a new substrate

Whenever you load a new substrate type into your printer, you must choose a substrate preset for it.

1. If no specific preset is available, try using a generic preset in the same substrate category.
2. For full control of your preset, clone a generic preset and adjust the settings manually.

Prepare the printer for a new substrate

Try to ensure that your printer is in a suitable state for creating a new preset.

1. Run any pending maintenance task, in particular printhead checks and alignment.
2. Stop the print queue and wait for the printer to finish the current job. No jobs should be sent to the printer until the new substrate preset is complete.
3. Choose a suitable carriage beam printing position.

Add a substrate preset

To clone a substrate preset, follow these steps:



http://www.hp.com/go/latexRseries/add_new_media

You may want to add a new substrate preset for various reasons:

- To assign a name of your own choice to the preset.
- To adjust the preset to the precise characteristics of your substrate.
- To adjust the preset to your intended use of the substrate, which may range from highest-quality printing to fast production output.

HP strongly recommends loading the substrate for which the preset is intended into the printer before proceeding with this process.

1. Go to the Internal Print Server and tap , among the icons at the bottom of the screen.



2. Select a preset from the Substrate Library.



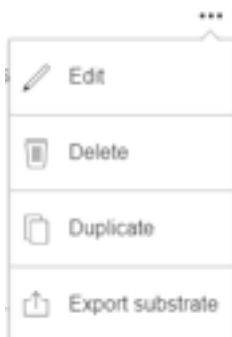

3. Tap **Duplicate** to clone the preset, and enter a name for the new preset.

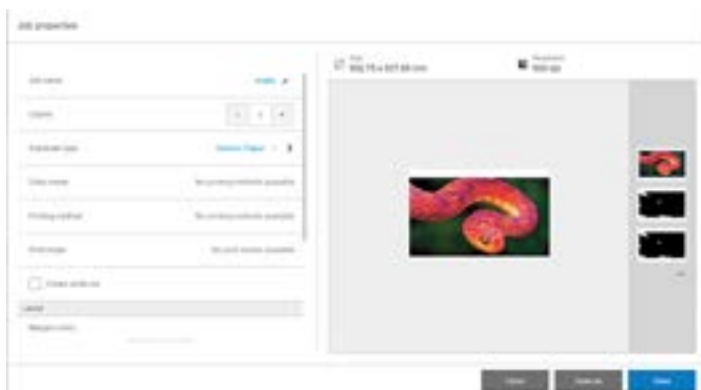

4. Modify a substrate preset: Tap the 3 dots icon, then the  icon of the print mode that you want to modify; or tap **Add new print mode**. You can delete or change the name of any print mode; although you should keep at least one print mode.



 **NOTE:** The printing method and number of passes in an existing print mode cannot be changed. If you want to change either one of them, create a new print mode.

 **NOTE:** You are not allowed to create two print modes with the same printing method, number of passes, and ink density.

5. If you selected **Add new print mode**, you must now define your new print mode by editing its properties, and test it.



6.
 - **Print mode name:** Choose a name to identify the newly created print mode.
 - **Heat-sensitive substrate:** Enable this option if the substrate suffers some deformation at high temperatures. Enabling this option will increase the number of passes and reduce throughput, so use it only when needed.

 **NOTE:** If you have not already loaded the substrate, you can load it now.

- **Color:** Choose the color mode from those available.
 - **CMYK** (4 colors)
 - **CMYKcm** (6 colors)
 - **CMYKcm+W** (6 colors + white)

In this case, you must select the amount of white ink to use, and how to position the white layer with respect to the colored layer:

- **Underflood:** The white layer is printed underneath the colored layer.
- **Overflood:** The white layer is printed on top of the colored layer.
- **Spot:** The white ink is printed at the same time and in the same way as the other inks.
- **CMYKcmWCMYKcm (sandwich)**
 - No back light: Intended for dual-sided applications. Available only for frontlit substrates. You can see the print from both sides of the substrate.
 - Back light from printed side: Intended for day & night applications. Available only for backlit substrates. You will always see the print through the substrate. With a front light you will see side A; when the substrate is retro-illuminated you will see a mix of both sides.
 - Back light from not-printed side: Intended for day & night applications. Available only for backlit substrates. You will always see the print from the printed side, not through the substrate. With a front light you will see side B (the printed side); when the substrate is retro-illuminated you will see a mix of both sides.
- **Number of passes:** Choose the number of passes, which is inversely related to throughput. More passes mean lower printing speed but allow a higher ink density and/or higher curing capacity. See [Recommended print modes \(introduction\) on page 234](#).
- Save the settings.
- Load the substrate.
- Tap **Print test** to print the ink drying and color saturation test.

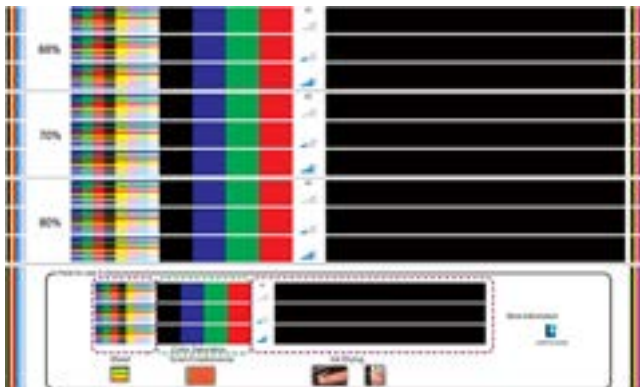

By printing this test you will be able to assess different color densities and different OC levels, leading to differences in color saturation, scratch resistance, durability, and ink drying capacity in the same plot.

Follow the instructions on the print to assess the results:

- Check the bleeding and coalescence to identify the correct ink density.
- For the chosen ink density, test the overcoat level by scratching the print with your fingernail.

Move on to part 2 and adjust the values according to your observations of the test print.

- **OC level:** To enhance durability, including resistance to rubbing or scratching, different levels of OC can be selected. A low OC level may be enough for prints that you intend to laminate; however, prints for long-lasting applications may require a higher OC level.
- **Ink density:** Ink density is related to color saturation. If you want more saturated colors, increase the ink density.

 **IMPORTANT:** To change the ink density and overcoat level values, you can print the test described above. Check it and choose the number in the pull-down color-saturation menu that matches your preferences in terms of curing and drying.

If you cannot get satisfactory results, try changing the temperature and reprint. You can also change the advanced settings.



Advanced settings

- **Drying temperature (°C):** Increase print-zone heat to dry faster. Be aware that some substrates are heat-sensitive. An increase in temperature can cause substrate warping, deformation, or wrinkles.
- **Latex optimizer level:** Increase optimizer level to reduce bleeding and coalescence, and increase the sharpness of the image.
- **Inter-pass delay offset:** Add an interpass delay offset if the print is not sufficiently dry or sufficiently cured. It reduces the printing speed and throughput, for the same number of passes.
- **Printing airflow pressure:** Increase drying pressure to dry a wider area. This improves drying performance.
- **Curing airflow pressure:** Increase curing pressure to cure a wider area. This improves curing performance.
- **Curing height:** Increasing curing height reduces curing performance but can help to avoid deformation of heat-sensitive substrates, as well as reducing printing defects caused by air-blowing orifices of the impinging plate.

If you need to adjust some of these settings, see the recommendations of the table below. In the table you can find the recommended step (number of units to increase or decrease) for each adjustable setting in order to see the impact signal.

Table 4-1 Recommendations

| Setting | Unit | Recommended step change |
|--------------------|------|-------------------------|
| Drying temperature | °C | 5 |

Table 4-1 Recommendations (continued)

| Setting | Unit | Recommended step change |
|--------------------|-------|-------------------------|
| Drying AF | Pa | 10 |
| Curing temperature | °C | 5 |
| Curing AF | Pa | 100 |
| Curing height | mm | 5 |
| PT | % | 3 |
| OC | level | 0.5 |
| Inter-swath delay | ms | 250 |
| Vacuum | Pa | 250 |

Apart from adding a new print mode, you can alternatively print the ink drying and color saturation test with the existing print modes, but for a new substrate. The workflow is similar to adding a new print mode.

For detailed information about print-quality troubleshooting, see [Troubleshoot print-quality issues on page 171](#).

- **Automatic color calibration:** Color calibration is recommended to ensure color consistency. This process is automatic and takes around 15 minutes.

Color calibration is supported only for frontlit white substrates. HP does not recommend attempting it with backlit, transparent, or non-white substrates.

- If you want to use your own ICC profile, you can create it at this point.

Curing temperature: The curing temperature enables latex curing and film formation. You could increase the temperature if you see that the ink is not dry enough. Be aware that some substrates are heat-sensitive. An increase in temperature can cause substrate warping, deformation, or wrinkles.

Expert mode

Expert Mode allows the operator to create new print modes on their custom profiles.

To enable the Expert mode in the IPS, first tap Preferences , then “system”, and enable the “Expert Mode”



A confirmation message will appear to alert about the potential consequences of enable on. Select “Continue anyway” if you agree.

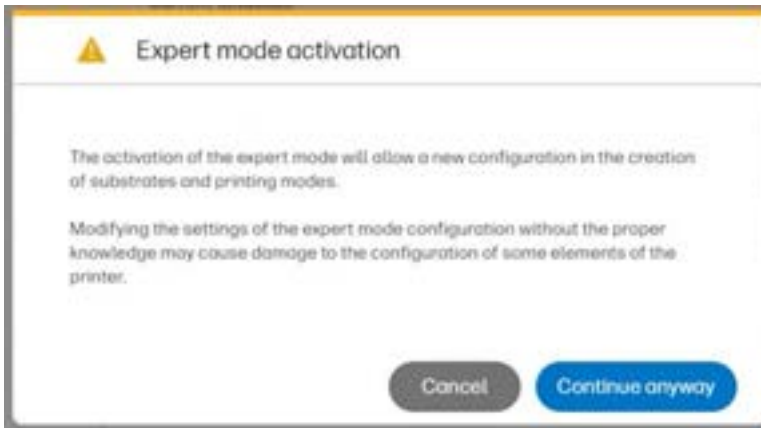

Once enabled, the main menu in the IPS will show that this mode is ON

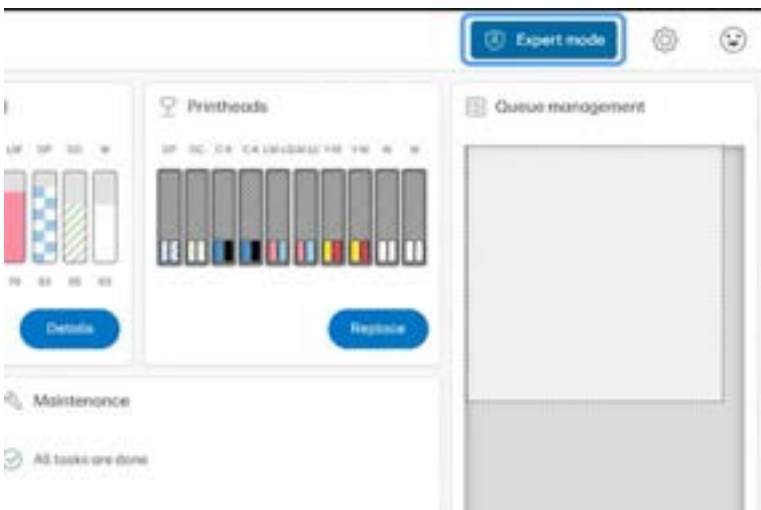

Online search - HP Media Locator

You can search online for a substrate preset by using the online search function within the Substrate Library control-panel menu.

The printer connects to the HP Media Locator database on the Internet and allows you to search all available substrate presets for your particular printer model, including HP and third-party substrate brands. Various substrate presets may be available, and the database of substrate presets is continuously updated and expanded. You will always get the most up-to-date content in this way.



When the printer is connected to the database (this may take a few seconds), a list of all available substrate presets for your printer model is displayed. You can browse the list by scrolling it, and get details on any preset by tapping its name.

Besides browsing, you can look for presets using free-text search, which allows you to type in any text using an on-screen virtual keyboard; all substrate presets containing that text in any part of their name or description will be displayed. For example, if you search for "vinyl" then substrate descriptions such as "self-adhesive vinyl" or "vinyl banner" will match and be displayed. The search is case-insensitive; that is, "vinyl" will match both "vinyl" and "Vinyl".

Once you have located the substrate preset of your choice, it will show you if the material works with generic profile or requires a specific OMS package. If a specific profile is required, selecting its download icon will queue it for automatic download and installation in the background. You can select as many substrate presets as you want for download and installation (they will be processed in the order that they were selected). You can return to another part of the Media Manager or another control-panel screen at any time after queuing presets for download, and this will not interrupt the download and installation process.

Once a substrate preset has been downloaded in the background, it is checked and installed on the printer's hard disk. Go to: **Substrate Library** and select **Import Substrate**.

The new substrate preset now appears in the Substrate Library together with all previously installed and factory-provided presets, and is ready for use.

Some supported RIPs may implement a similar online substrate-preset search function accessing the same HP Media Locator database. Whether you use the printer's control-panel search or RIP-based search does not matter: the end result is the same. Supported RIP software synchronizes its substrate preset list with the printer, so that printer and RIP will always have the same list.

Select the number of passes

Increasing the number of passes will tend to improve the print quality but reduce the speed of printing.

Print modes explanation

For example, 12p-100 means:

- 12 passes
- 6 colors
- Ink density 110%

 **NOTE:** The following table is for the normal ink limit unless otherwise indicated.

Table 4-2 Color print modes

| Color print mode | Corrugated plastic | PVC foam | Coated cardstock | Uncoated cardstock | Plastic foamboard | Paper foamboard | Plastic solid | ACP | Wood | SAV | Paper | Banner |
|------------------|--------------------|----------|------------------|--------------------|-------------------|-----------------|---------------|--------|--------|--------|--------|--------|
| DRAFT | 4p60 | - | - | - | - | - | - | - | - | - | - | - |
| SPEED | 6p70 | 6p70 | 6p70 | 6p70 | 6p70 | 6p70 | 8p80 | - | 6p90 | 6p80 | 6p70 | 6p70 |
| STANDARD | 10p90 | 12p100 | 12p100 | 12p100 | 12p100 | 12p100 | 12p90 | 12p100 | 12p120 | 12p110 | 12p100 | 12p90 |

Table 4-2 Color print modes (continued)

| Color print mode | Corrugated plastic | PVC foam | Coated cardstock | Uncoated cardstock | Plastic foambord | Paper foambord | Plastic solid | ACP | Wood | SAV | Paper | Banner |
|------------------|--------------------|---------------|------------------|--------------------|------------------|----------------|---------------|---------------|---------------|---------------|--------|--------|
| QUALITY | 16p110 | 16p110 | 16p110 | 16p110 | 16p110 | 16p110 | 16p110 | 16p110 | 16p140 | 16p120 | 16p110 | 16p120 |

Available in generic

Available in predefined Sow All

Table 4-3

| | Corrugated plastic | PVC foam | Coated cardstock | Uncoated cardstock | Plastic foambord | Paper foambord | Solid plastic | ACP | Wood | SAV | Paper | Banner |
|-------------------------|--------------------|----------|------------------|--------------------|------------------|----------------|-----------------|------------|--------|------------------|--------|--------|
| Low opacity (60%) | | | | | | | | H.Quality* | | UF, OF, SP | | |
| Standard opacity (100%) | | UF, SP | | | | | UF, OF, SP | | | UF, OF, SP | | |
| High opacity (160%) | UF, SP | UF, SP | UF, SP | UF, SP | UF, SP | UF, SP | UF, OF, SPSW 3L | UF, SP | UF, SP | UF, OF, SP, SW3L | UF, SP | UF, SP |
| Extra opacity (260%) | | UF, SP | UF, SP | UF, SP | UF, SP | UF, SP | UF, OF, SP | UF, SP | UF, SP | | | |
| W360 | | | | | | | | | | SW5L | | |

Available in generic

Available in predefined Sow All

* Special print mode using a white ink to improve quality on ACP

 **NOTE:** More specific settings for many substrates from different vendors are available in the HP Substrate Finder at <http://www.hp.com/go/latexmediafinder/>.

 **NOTE:** After selecting the number of passes in the Add New Print Mode screen, make sure to reset your print mode to default category values for that print mode.

Recommendations for optimal color calibration

The color calibration test chart is printed using a fixed print mode with a high number of passes and fixed curing and drying settings to ensure printing consistency.

- Parameters affecting substrate advance should be fine-tuned, printheads should be aligned, and nozzle health should be checked, before starting color calibration for the first time. Crosses at the sides of the color target will help you to diagnose substrate-advance problems.

- Perform color calibrations with the printer in its normal environment and in typical condition. For example, calibrate when the printer has been printing for some time, not at the beginning of the day or after an idle period.
- Advance the substrate about 75 cm (30 in) before printing the color target, to ensure that the substrate is fresh.

5 Create and manage print jobs

The following sections provide details for this topic.

Add a new print job

To add a new job from any other location, follow these steps:

Each print job must be created in your Raster Image Processor (RIP) and then added to the Internal Print Server.

When the RIP has generated a print job, its output folder will contain at least three files:

- An XML or JDF file containing job settings
- A low-resolution TIFF file for use in previews
- At least one high-resolution TIFF file containing the image to be printed

 **IMPORTANT:** The output folder should be the shared folder on the Internal Print Server computer that was created during printer installation. The Internal Print Server cannot take files directly from the network because access would not be fast enough.

 **IMPORTANT:** To make adding new jobs easier, HP recommends configuring the printer as follows:

- Create a shared folder (hot folder) in the printer's built-in computer (this is done when the printer is installed).
- Configure your RIP software to use the above hot folder as its output folder.

With this configuration, each job created by the RIP will be automatically added to the print queue.

1. Go to the Internal Print Server and tap **Queue management**.



2. Tap . Navigate to the folder containing the print job files, and tap **Open** to import the job into the Internal Print Server.



 **TIP:** You can sort the list by any column.

3. Your job is added to the corresponding slot of the job repository. Double-tap the job. The next dialog box displays information about the job.

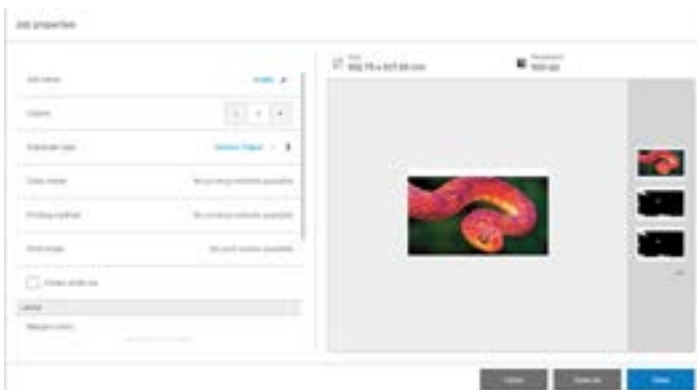

Tap **Save** if you accept the displayed properties. For more information about changing the job properties, see [Job properties on page 78](#).

Job properties

From the Internal Print Server's main window, double-tap the print queue to open the Job Properties window.

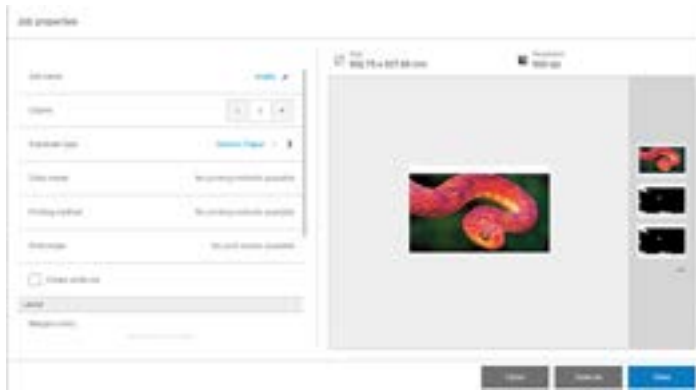

Use the **Save As** button to create a copy of an existing job with a different name.

This dialog has the following basic options:

- **Copies**
- **White mode:** Visible only when **Color + white** is selected
- **Print mode**
- **Choke**
- **Margins:** Left, right, top, bottom
- **Alignment:** Left, center, right

Margins, alignment, and number of copies can also be selected to the right of the preview area.

Although the substrate and print mode can be changed from this dialog window by using the change button, HP recommends not to do so because it may adversely affect print quality. It is better to change the substrate and the print mode from the RIP.

 **NOTE:** The Internal Print Server gives you a warning if you select layout changes that are not compatible with your selections in the RIP.

6 Handle the ink system

Correct handling of the ink system is essential for effective printing.

Ink system components

The following sections provide details for this topic.

3 Liter Eco-Carton ink cartridge

The printer's eight large Eco-Carton ink cartridges supply black, cyan, light cyan, magenta, light magenta, yellow, optimizer, and overcoat ink to the printheads. R530W printers can also use white Eco-Carton ink cartridges. These cartridges store the ink and connect to the printheads, which deposit it onto the substrate.

White cartridges have two connectors because the box contains two bags.



Each cartridge contains 3 liters of HP Latex ink, and consists of a bag within a recyclable cardboard box. The cartridges are kept on a shelf at the bottom of the printer. The colored ink cartridges, along with the optimizer and overcoat cartridges, are stored on a shelf at the bottom of the printer, while the white ink cartridges are located on the right side of the printer, beneath the screen.

HP Latex Optimizer enables high quality at high speed. HP Latex Optimizer consists of positively-charged (cationic) polymers suspended in a colorless, water-based ink vehicle. It reacts with the ink pigments, which are negatively-charged (anionic), to immobilize them rapidly on the print surface. This produces sharp text and image detail by suppressing feathering and color bleed especially at high productivity levels.

HP Latex Optimizer also enables the drying and curing process of the HP Latex inks to operate at lower temperatures and to be more energy-efficient, which has the additional benefits of allowing wide substrate support and reduced power consumption.

Check the regulatory and safety information label on the cartridge to ensure that no special ventilation is needed and no hazardous waste is created.

CAUTION: Observe precautions when handling ink cartridges because they are ESD-sensitive devices. Avoid touching pins, leads, and circuitry.

Excessive pressure on a cartridge can cause ink leaks. Avoid putting pressure on cartridges while they are connected to the printer. In particular:

- Always disconnect cartridges from the printer before handling them.
- Never place anything heavy-more than 1 kg (2.2 lb) - on top of a cartridge.
- Take care not to drop a cartridge.
- Do not try to force the last of the ink out of an almost-empty cartridge by pressing the ink bag inside the cartridge.

Ink cartridges require no maintenance or cleaning, but you must follow the instructions on the label before installation. High-quality printing results continue even when the ink levels are getting low.

 **CAUTION:** Non-genuine or altered cartridges are not supported by the printer; if they are detected, printing is stopped.

 **NOTE:** Dynamic security enabled printer. Only intended to be used with cartridges using an HP original chip. Cartridges using a non-HP chip may not work, and those that work today may not work in the future. More at: <http://www.hp.com/go/learnaboutsupplies>.

 **NOTE:** This printer is not designed to use continuous ink systems. To resume printing, remove any continuous ink system and install genuine HP (or compatible) Eco-Carton ink cartridges.

 **NOTE:** This printer is designed for ink cartridges to be used until they are empty. Refilling cartridges prior to depletion could cause your printer to fail. If this happens, insert a new cartridge (either genuine HP or compatible) to continue printing.

Replace a 3 liter Eco-Carton ink cartridge

During the normal lifetime of a cartridge, no specific maintenance is required. You should replace a cartridge when it has reached its expiration date (18 months of life), or when the printer requests it.

See the ink cartridge information on the control panel for the expiration date.

Remove an Eco-Carton ink cartridge

If you need to remove an Eco-carton ink cartridge, perform the following procedure.

 **NOTE:** After removing or installing an Eco-carton ink cartridge, clean the connection area on both the printer and the cartridge if it appears dirty.

1. Disconnect the cartridge connector by pressing the tabs on each side of it and pulling it gently away from the cartridge.

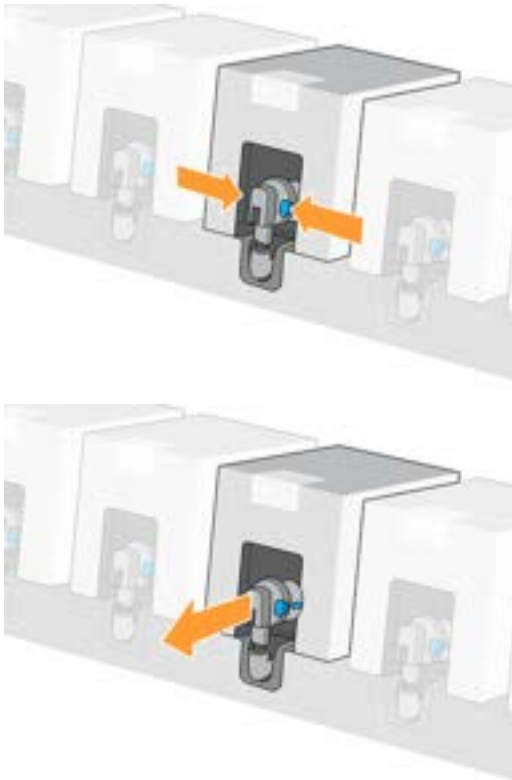

2. Remove the empty cartridge from the printer.

Insert an Eco-Carton ink cartridge

If you need to insert an Eco-carton ink cartridge, perform the following procedure.

 **NOTE:** After removing or installing an Eco-carton ink cartridge, clean the connection area on both the printer and the cartridge if it appears dirty.

 **NOTE:** The ink cartridge is supplied in an insulating bag; do not open it until you are ready to use the cartridge.

1. Check that the new cartridge is of the correct color.

2. Turn the cartridge four times, rotating it through a total of 360 degrees, to ensure that the ink is well mixed before use.



 **IMPORTANT:** Before installing a white-ink cartridge, tilt it forwards and backwards 60 times. This should take less than 2 minutes. This information is provided on the white ink cartridge.

 **CAUTION:** Installing an unshaken white-ink cartridge may lead to print-quality issues, printhead failure, or ink delivery system malfunction.

3. Tear off the square cover of the new cartridge, then fold the handle inwards.
4. Insert the new cartridge into the correct place on the printer and connect the connector.

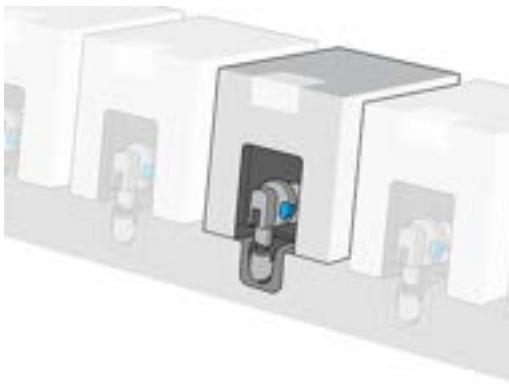

Printheads

The printheads deposit ink on the substrate. Each printhead, except for the optimizer, overcoat, and white printheads, is connected to two ink cartridges.

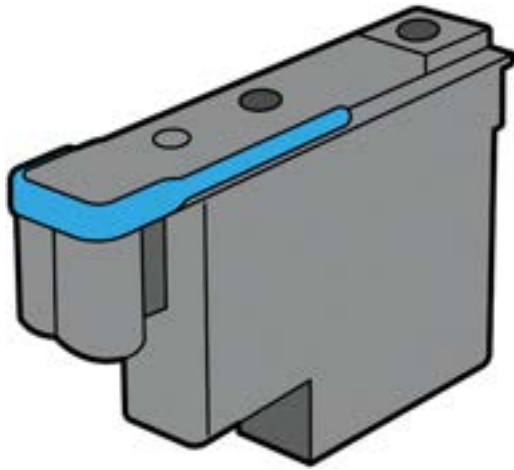

The printheads are extremely durable and do **not** need to be replaced every time an ink cartridge is replaced. They provide excellent results even when the ink cartridges contain a low level of ink.

To maintain optimum print quality, the printheads are automatically tested at regular intervals, and automatically serviced when necessary. This takes a little time and can occasionally delay printing.

When a printhead eventually needs to be replaced, the control panel will display a message.

There are two kinds of printheads

- Optimizer, for use with optimizer ink
- Universal, for use with all other inks: black, cyan, magenta, yellow, light cyan, light magenta, overcoat.
- Two white printheads

⚠ **CAUTION:** Avoid touching pins, leads, and circuitry when handling printheads because these elements are sensitive to electrostatic discharge. Such devices are called ESD-sensitive devices. Electrostatic discharges are one of the main hazards to electronics products. This type of damage can reduce the life expectancy of the device.

⚠ **CAUTION:** If you want to remove a printhead from the printer and preserve it for later use, reinstall the cap and plug, but never install a clear optimizer cap or white plug on a non-optimizer printhead. Optimizer printheads have clear caps and white plugs, while the other printheads have orange caps and plugs. Installing the wrong cap and plug can cause irrecoverable printhead damage.

Replace a printhead

Guidance on how to remove and insert a printhead.



Remove a printhead

If you need to remove a printhead, perform the following procedure.

1. On the printer's IPS, tap , then **Replace printheads**.
2. The carriage moves to the removal position.

 - ⚠ **CAUTION:** If the carriage remains in the removal position for more than 3 minutes without inserting or removing any printheads, it will attempt to return back to its home position to the right.
 - ⚠ **CAUTION:** Observe precautions when handling printheads because they are ESD-sensitive devices. Avoid touching pins, leads, or circuitry.

3. When the carriage has stopped moving, the control panel prompts you to open the carriage cover.

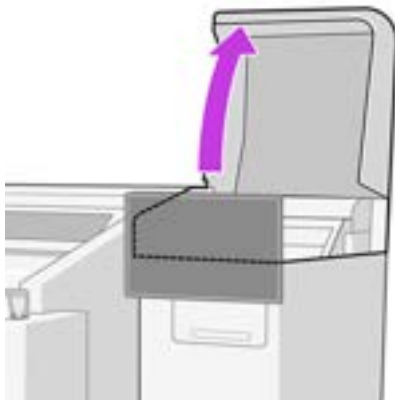
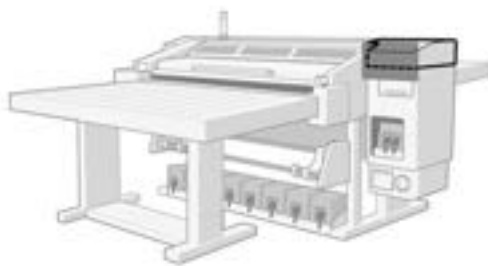

4. Pull up and release the latch on top of the carriage.

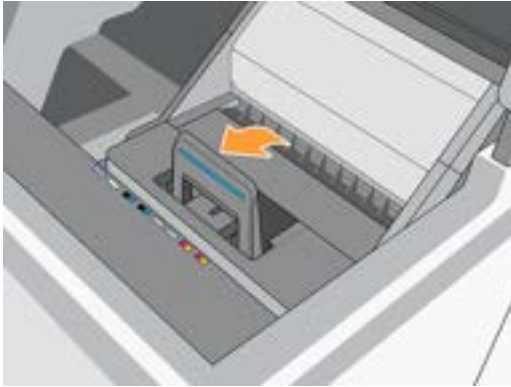

5. Lift up the cover. This provides access to the printheads.

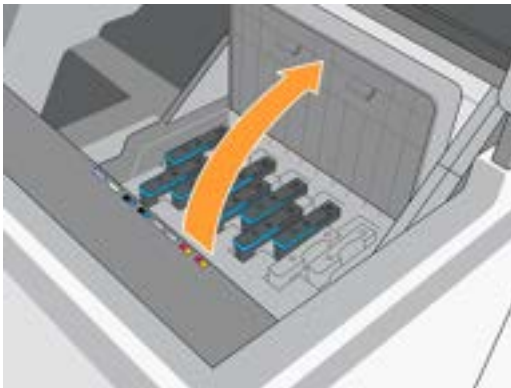

6. To remove a printhead, lift up the blue handle.

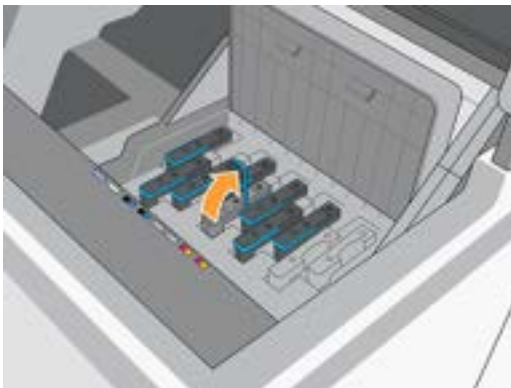

7. Using the blue handle, gently disengage the printhead, then gently pull it upwards until the printhead is released from the carriage.

⚠ CAUTION: Place a cloth below the printhead to prevent ink droplets from falling on the carriage.

⚠ CAUTION: Do not pull abruptly. That action can damage the printhead.

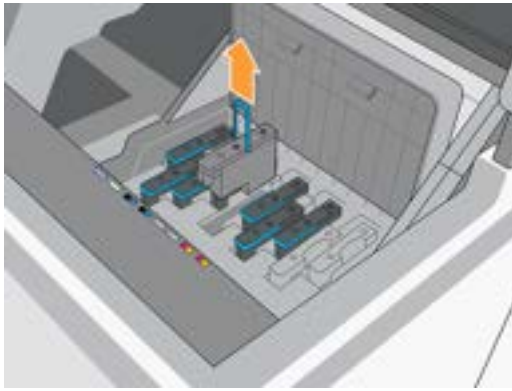

CAUTION: If you want to preserve the old printhead for later use, reinstall the cap and plug, but never install a clear optimizer cap or white plug on a non-optimizer printhead, or an orange cap or plug on an optimizer printhead. Optimizer printheads have clear caps and white plugs, while the other printheads have orange caps and plugs. Installing the wrong cap and plug can cause irrecoverable printhead damage.

8. The control-panel display identifies the missing printhead.



9. Check whether the fluid interconnect tower has a lot of ink on it. If so, clean it with a lint-free cloth before inserting a new printhead.

The fluid interconnect tower (B) is the structure into which the printhead (A) is inserted, and through which the ink arrives at the printhead.

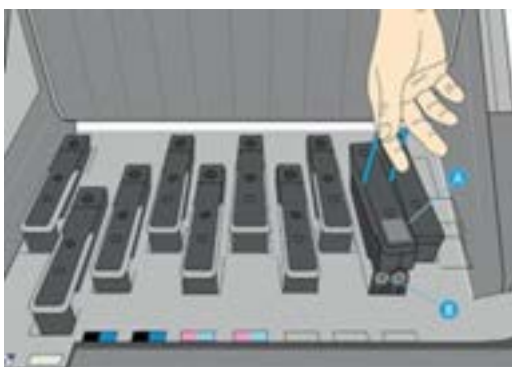

Insert a printhead

If you need to insert a printhead, perform the following procedure.

1. Remove the orange protective caps by pulling them down.

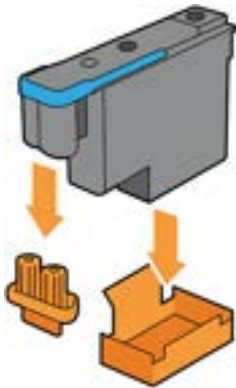

 **NOTE:** The optimizer protective caps are white or transparent.

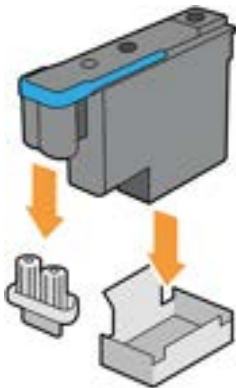

2. The printhead is designed to prevent you from accidentally inserting it into the wrong slot. Check that the colored label on the printhead matches the colored label of the carriage slot into which the printhead is to be inserted.
3. Insert the new printhead into its correct slot in the carriage.

 **CAUTION:** Insert the printhead slowly and vertically, straight down. It can be damaged if you insert it too quickly, or at an angle, or if you rotate it as you insert it.

You may feel some resistance when inserting the printhead, so you need to press it down firmly but smoothly. You should hear a beep and see confirmation on the control-panel display that the printhead has been inserted.

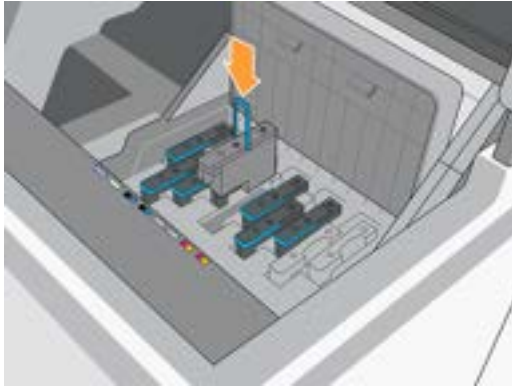

4. Insert all of the other printheads that need to be installed, ensure that the printheads are completely inserted, and close the carriage cover.

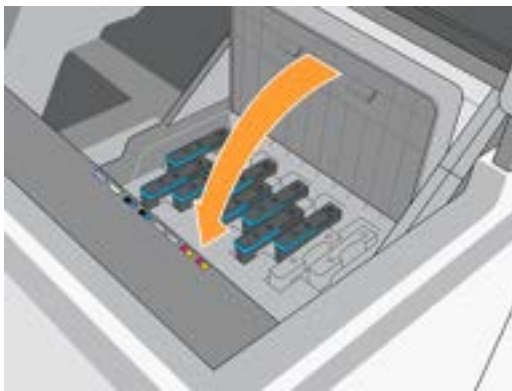

5. Lower the latch to rest on the carriage cover.

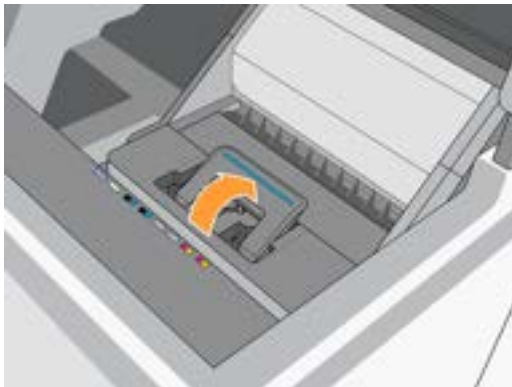

When all of the printheads have been inserted correctly and the printer has accepted them, the printer beeps.

 **NOTE:** If the printer does not beep when you insert the printhead and the **Replace** message appears on the control-panel display, you may need to reinsert the printhead.

6. Close the carriage cover.

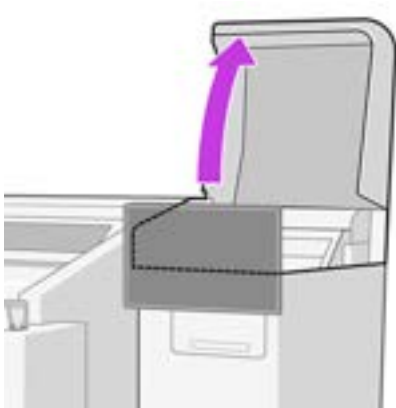

7. The control-panel display confirms that all of the printheads are correctly inserted. The printer starts checking and preparing the printheads. The default routine process, when all printheads are changed, takes up to 18 minutes. If the printer identifies a problem when preparing the printheads, the process takes longer, up to 30 minutes. For a single printhead insertion, the time varies between 10 and 20 minutes. After all printheads are checked and prepared, the printhead realignment procedure runs automatically if substrate is loaded.

How to store and ship printheads

If you ever need to remove the color printheads from the printer and store them, take the following precautions.

 **IMPORTANT:** This section does not apply to white printheads. For more information, see [White printhead storage system on page 117](#).

- Ensure that the orange nozzle cap is correctly placed on the printhead.

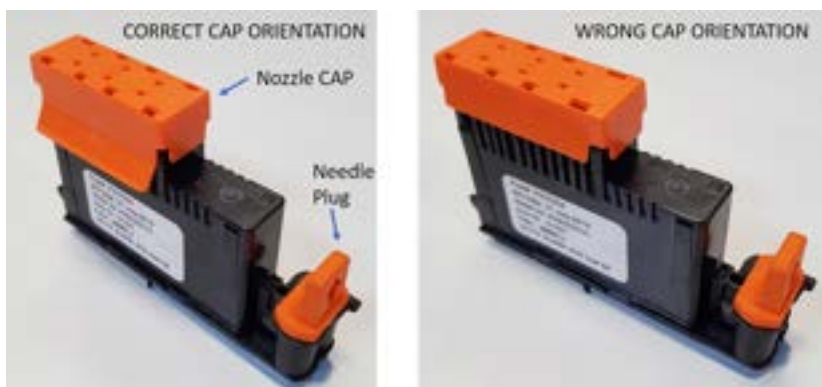

 **IMPORTANT:** Ensure that the correct nozzle cap and needle plug are used for each printhead.

- The optimizer printhead has a white nozzle cap and needle plug.
 - All other color printheads have an orange nozzle cap and needle plug.
-
- **Do not** interchange colors, which can permanently damage nozzles. HP recommends storing the packaging material of each printhead (box, kit, nozzle cap, and needle plug) safely in case of need.

- Store each printhead with nozzles facing down: that is, resting on the nozzle cap. Do not store printheads with nozzles facing up.

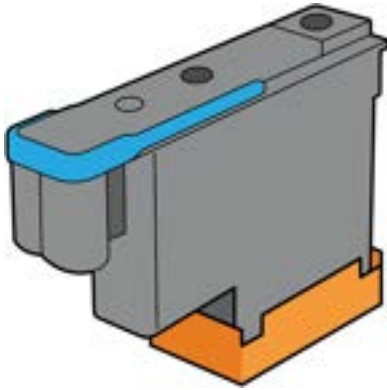

Ink Maintenance cartridge

The maintenance cartridge cleans and maintains the printheads, and seals the printheads when they are not in use to prevent them from drying out. It is also used to store waste ink.



The maintenance cartridge is used to clean the printheads. You are notified when 90% of the cleaning roll or the ink collection unit have been used. The lifespan of these consumables will depend on the print mode in use. On average, a new maintenance cartridge lasts for about 3,150 m² (34,000 ft²) of printed area for color print modes and about 1,600 m² (17,200 ft²) for white print modes.

IMPORTANT: Keep the maintenance cartridge horizontal when removing it, to avoid spilling ink.

To maximize maintenance-cartridge efficiency, see [White-ink best practices on page 123](#).

NOTE: These figures can vary considerably depending on the image density, the print mode, and the ambient temperature. The cloth will be exhausted much faster with a high-density print, many passes, and a hot environment.

NOTE: The maintenance cartridge is checked to detect end of roll when the printer is turned on and at the end of each print job.

The printer will refuse to start a print job if it detects the end of the cleaning roll, or if the maintenance-cartridge ink collection unit is full. You should then replace the maintenance cartridge.

Replace the ink maintenance cartridge

You should replace the maintenance cartridge when prompted to do so by the control panel.

1. On the printer's IPS, tap  .

2. In the Maintenance Cartridge section, tap **Replace > Start**.
3. The maintenance cartridge is located in a slot underneath the touch panel, at the front of the printer. Open the door.

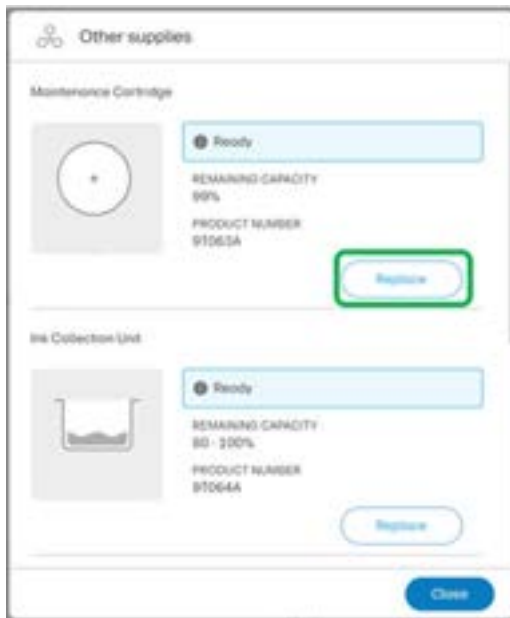

4. The maintenance cartridge is located in a slot underneath the control panel, at the front of the printer. Open the door.

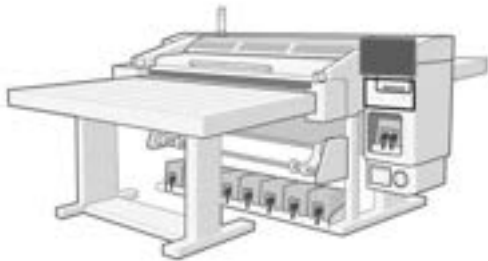

 **IMPORTANT:** When removing a maintenance cartridge, remember that it is full of ink. Therefore:

- Wear gloves.



- Remove it carefully and horizontally to avoid splashing.
- Always handle and store the replaced maintenance cartridge upright, facing up.

⚠ WARNING! Make sure that the printer wheels are locked (the brake lever is pressed down) to prevent the printer from moving.

5. To remove the cartridge, just slide it out.



6. When you have slid it out partway, hold it on each side with both hands: it is heavy.



📎 IMPORTANT: Slide it out horizontally to avoid spills, as it is full of ink.

7. Store the old maintenance cartridge.

- Remove the plastic cover from the new maintenance cartridge.



- Insert the maintenance cartridge into the slot, in the direction indicated by the arrow.



- Push the maintenance cartridge in until it does not protrude from the slot. You will notice that the printer takes it; do not use excessive force.

 **NOTE:** The control panel will not show the new maintenance cartridge until the door is closed.

- When you have inserted the maintenance cartridge into the printer, close the door.





- Clean the encoder strip: see [Clean the encoder strip on page 139](#).

 **NOTE:** Before it can resume printing, the printer needs all the ink cartridges, printheads, and maintenance cartridge to be installed, and the printer window and maintenance cartridge door to be closed.

Ink collection unit

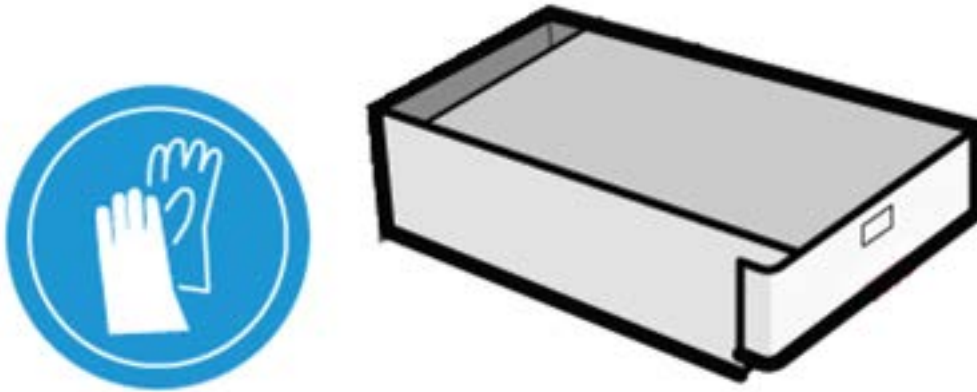
The ink collection unit is a supply placed inside the maintenance cartridge where the waste ink is stored. It can be replaced once is full many times as needed until the maintenance cartridge is also ended.



 **IMPORTANT:** Keep the ink collection unit horizontal when removing it to avoid spilling ink

You are notified when the remaining available capacity of the ink collection unit is between 20% and 0%. It lasts for about 1,250 m² (13,450 ft²) of printed area for color print modes and about 580 m² (6,240 ft²) for white print modes. Once it reaches the end of its life the printer will refuse to start a print job or a servicing routine. You should then replace the ink collection unit with a new one. A cap to prevent ink splashes during handling is provided with the supply.

 **NOTE:** These figures can vary considerably depending on the image density, the print mode, and the ambient temperature. The cloth will be exhausted much faster with a high-density print, many passes, and a hot environment.

Replace the ink collection unit

You should replace the ink collection unit when prompted to do so by the control panel.

1. On the printer's control panel, tap 

2. In the Ink Collection Unit, tap Replace > Start.

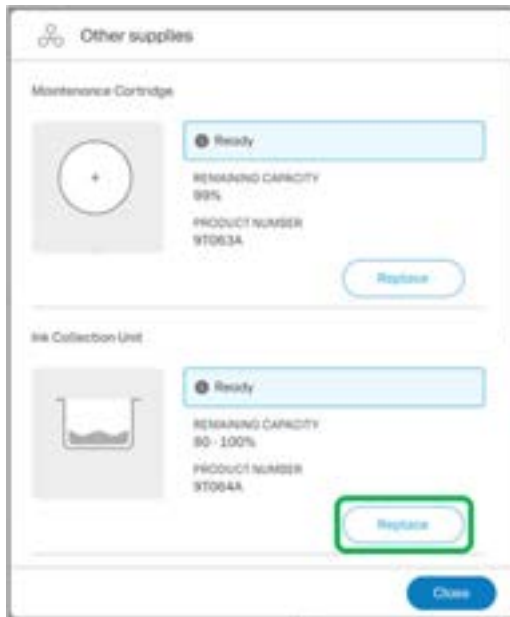

3. The maintenance cartridge is located in a slot underneath the touch panel, at the front of printer. Open the door.

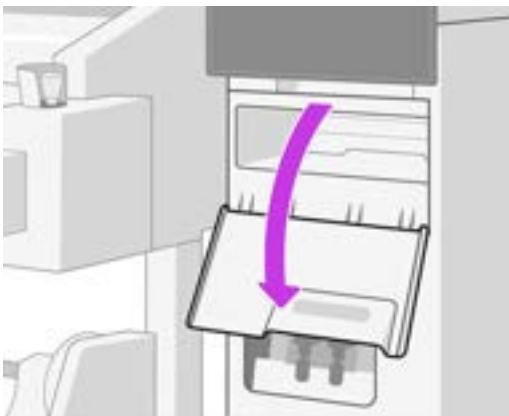
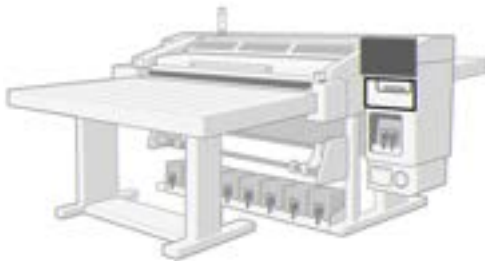

 **IMPORTANT:** When removing a maintenance cartridge, remember that it is full of ink. Therefore:

- Wear gloves.
- Remove it carefully and horizontally to avoid splashing.
- Always handle and store the replaced maintenance cartridge upright, facing up.

⚠ WARNING! Make sure that the printer wheels are locked (the brake lever is pressed down) to prevent the printer from moving.

4. To remove the cartridge, just slide it out.



5. When you have slid it out partway, hold it on each side with both hands: it is heavy.



📄 NOTE: Slide it out horizontally to avoid spills, as it is full of ink.

6. Place the Maintenance cartridge on a flat surface and remove the Ink collection unit as shown below:

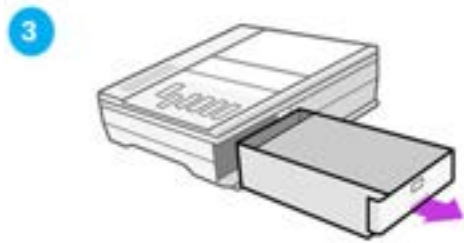
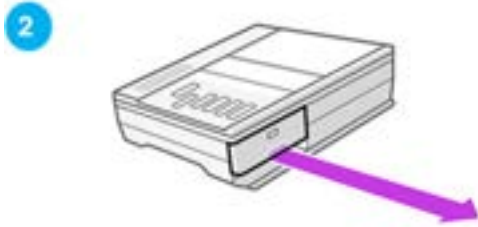

7. Install the new one as shown below:

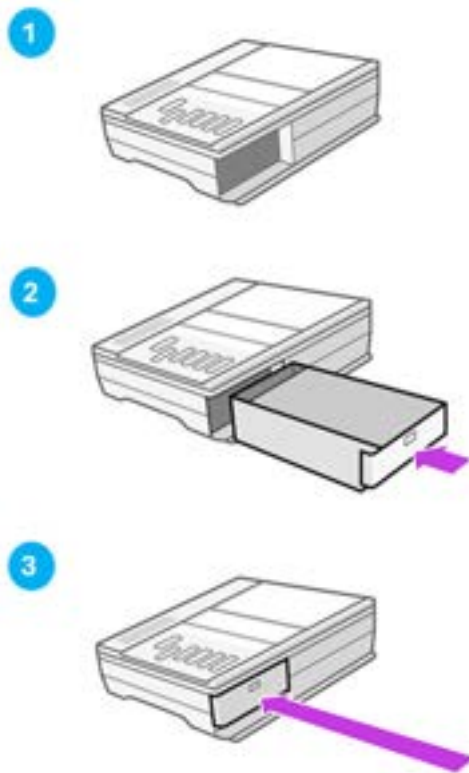

8. Insert the maintenance cartridge into the slot, in the direction indicated by the arrow.



9. Push the maintenance cartridge in until it does not protrude from the slot. You will notice that the printer takes it; do not use excessive force.

 **NOTE:** The control panel will not show the new maintenance cartridge until the door is closed.

10. When you have inserted the maintenance cartridge into the printer, close the door.



11. Clean the encoder strip. See [Clean the encoder strip on page 139](#).

 **NOTE:** Before it can resume printing, the printer needs all the ink cartridges, printheads, and maintenance cartridge to be installed, and the printer window and maintenance cartridge door to be closed.

Condensation collector

Vapors from high-productivity printing are condensed in the condensation collector for convenient disposal, avoiding uncontrolled condensation on windows, floors, walls, substrate, and so on.

The contents of the condensation collector cannot be dumped down the drain, but should be disposed of in accordance with local regulations and site operation. For further information, see <https://hpllatexknowledgecenter.com/applications/wasteprofiles/>.

The condensation collector should be replaced or emptied in the following situations:

- The printer shows a condensation collector alert on the control panel.
- The condensation collector has reached its capacity: see the level indicator on the collector.

 **NOTE:** The volume of condensation collected may vary depending on usage mode, room temperature, and humidity. This means that the condensation level shown on the control panel may not match the level inside the condensation collector.

1. At the control panel, tap .

- Information appears on the level of condensation in the collector. Tap the **Reset** button, and the control panel will explain how to proceed.

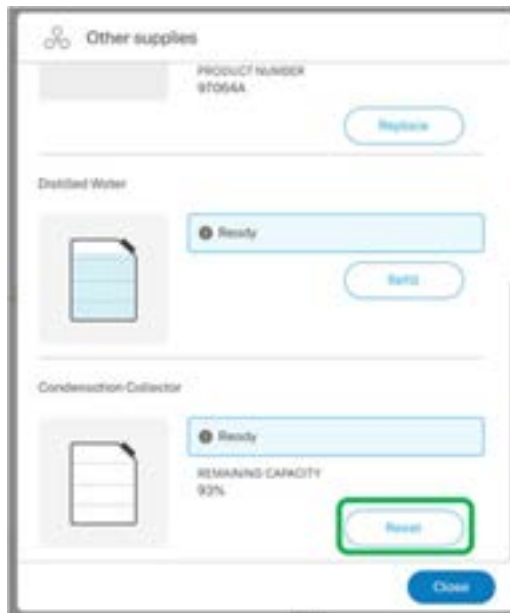

- When the collector has been emptied, remember to reset the counter by tapping the **Reset** button.
- The control panel asks you to confirm that the condensation collector level will be reset. Tap OK to confirm.

Ink system tips

For best results, always follow the guidelines described here.

- Follow the instructions on the control panel during installation.
- Avoid unnecessary removal of the ink cartridges.

Make sure that you comply with all applicable laws and regulations when disposing of ink system consumables.

Printing with white ink

Printing with white ink is useful mainly when printing on non-white substrates, such as dark, colored, metallic, or transparent substrates.

The following basic design techniques may be used:

- **Underflood:** A solid rectangle (or irregular shape) of white ink is printed as the first layer, then a colored image is printed as the second layer, on top of it. When used on a non-white or reflective surface, this can provide better color saturation or allow colors that are similar to the substrate color to be visible.
- **Overflood:** A colored image is printed as the first layer, then a solid rectangle (or irregular shape) of white ink is printed as the second layer, on top of it. This is most often done with transparent substrates to create a sign that is viewed on a light box (for example, a shopping mall map, airport advertisement, or bus stop signage). When viewed from the opposite side of the substrate on which it was printed, the image must be reversed (mirrored) in the RIP or application software before printing.
- **Spot color:** Any white shape (including text) that is cured with and in the same plane as the rest of the artwork, rather than in a separate plane or layer. In conventional (analog) offset or screen printing, this might be called a *knockout*, because none of the colors are overprinted.
- **Sandwich mode:** A white layer is embedded between two different images, allowing each image to be seen from one side of the substrate.

There is one type of white ink cartridge:

- 3-liter Eco-Carton ink cartridges, each consisting of a single cardboard box containing two bags. Turn the cartridge 60 times, rotating it through a total of 360 degrees, to ensure that the ink is well mixed before use.





 **IMPORTANT:** Before installing a white-ink cartridge, tilt it backwards and forwards 60 times.

White printheads need manual cleaning periodically, in addition to the automatic servicing that all printheads receive. This is explained in the supply box. It is important to ensure proper printer performance.

 **IMPORTANT:** White ink cartridges, and either white printheads or auxiliary white printheads, should remain permanently installed to avoid printhead damage, even if you are not currently using white ink in your jobs. The white recirculation requires a minimum level of ink in the cartridge to maintain the white system.

 **NOTE:** When printing a CMYK or CMYKcm image without a white under-fill on non-white substrate, color saturation may be reduced, depending on the color of the substrate.

 **NOTE:** White ink has a maximum shelf life of 12 months from the date of manufacture, or 6 months from the date of installation.

 **NOTE:** White ink has a tendency to settle over time.

White printhead storage system

The white printhead storage system allows you to extend the life of white printheads when they are not being used.

IMPORTANT: When white-ink printheads are installed, the printer performs automatic maintenance routines periodically to ensure that they function correctly.

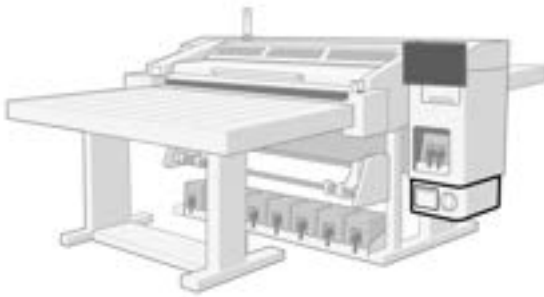

IMPORTANT: If you do not intend to use white ink, you should remove the white printheads and store them in the storage system. Otherwise some white ink will be wasted during routine maintenance and increase the procedure time.

1. Ensure that the printer is not trying to print: stop the print queue.
2. At the control panel, tap **Replace** in the Printheads section.
3. Remove the two white printheads from the carriage.

CAUTION: Place a cloth below each printhead to prevent ink droplets from falling on the carriage.

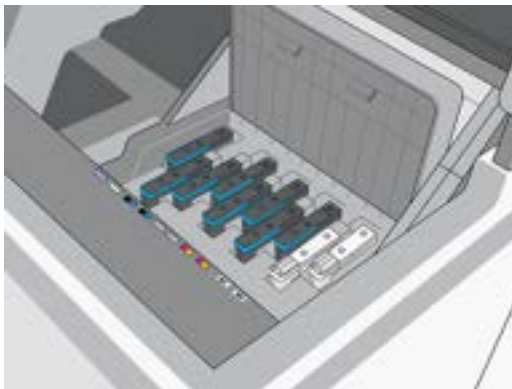

4. Check the bottoms of the white printheads. If you see some ink (which can happen because of the automatic recirculation), clean them gently with a soft, fiber-free cloth and de-ionized or distilled water. Also, clean the printhead turrets, where the printhead connects to the fluid interconnect tower, and the fluid interconnect tower itself if they are dirty, using the same methodology.

CAUTION: Do not use the same cloth to wipe optimizer and non-optimizer printheads. This may lead to unrecoverable nozzle defects.

NOTE: To provide the best possible printhead reliability, the white printheads may need to be cooled down. HP recommends following the cool-down process whenever the printer requests it, first removing the white printheads from the carriage.

Check whether the fluid interconnect tower has a lot of ink on it. If so, clean it with a lint-free cloth before inserting the printhead.

5. Remove the printhead storage box from the storage system.

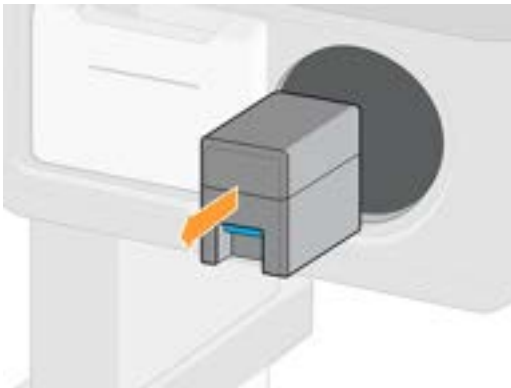

6. Open the storage box and remove both auxiliary printheads from it.

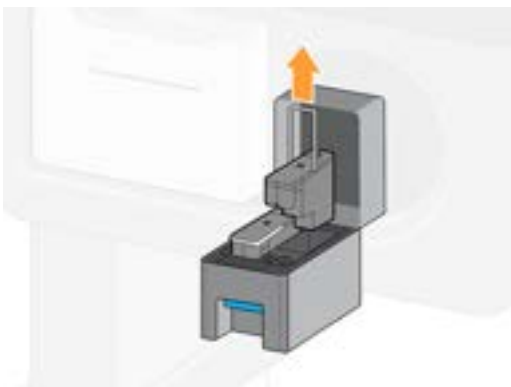
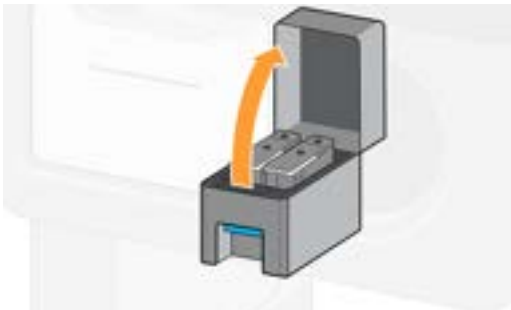

7. Check the bottom plate of each white printhead. If there is some ink on it (which can happen because of the automatic recirculation), clean it gently with a soft, fiber-free cloth dampened with de-ionized or distilled water.

⚠ CAUTION: Do not use the same cloth to wipe optimizer and non-optimizer printheads. This may lead to unrecoverable nozzle defects.

8. Regularly check the plastic needles in the printhead carriage slot, which protect the printheads. If necessary, clean them with distilled water, then dry them before installing the printhead.

CAUTION: Printheads should be kept either in the carriage slot or in the storage system, otherwise nozzles and needles may become clogged.

9. Put the white printhead into the storage box, then put the storage box back into the storage system.

IMPORTANT: The storage box is labelled. Be careful to put the white printhead into the correct slot.

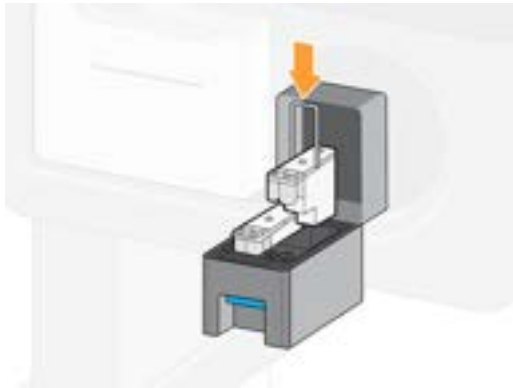

10. Insert the auxiliary white printhead into the carriage in place of the white printhead.

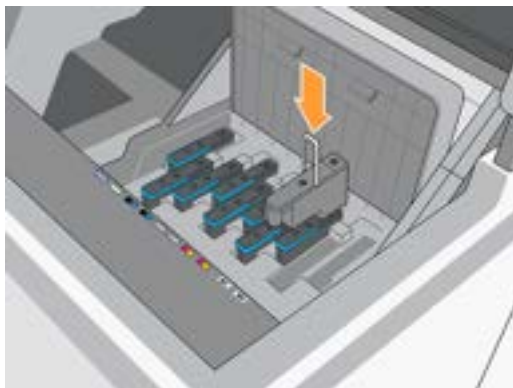

IMPORTANT: Do not try to print without a full set of printheads installed in the carriage.

IMPORTANT: If any component of the white module is broken, or if a white cartridge is empty, the recirculation process could be affected. You are recommended to replace these components promptly when necessary.

You can leave the white printheads in the storage system for as long as you like.

To use them again, reverse the above procedure.

IMPORTANT: Be careful to put each white printhead into its own white slot in the carriage.

IMPORTANT: The R530 printer should never be turned off: use sleep mode instead.

Automatic white-ink maintenance cannot occur when the printer is completely turned off; and the white-ink printheads cannot survive for more than 8 hours without maintenance.

 **IMPORTANT:** Do not swap the white printhead with the auxiliary printhead while the printer is turned off. The printer will not detect the change, which may affect the process.

Preparing a white job in your design software

Prepare the job using layers. Before sending it to the RIP, you should ensure that the part of the image to be printed in white is on a separate layer named **spot**: a name that the printer will recognize.

When the image is ready, send it to the RIP.

If your file does not have a layer named **spot**, you can add a white layer from the RIP.

Preparing the job in the RIP

In the RIP, choose the desired print mode. This selection places the white layer defined in the application into its desired position: Over, Under, or Spot (at the same level as the color layers). Assigning a print mode with white ink to a job with no white layer will cover the whole printing area with white. When ready, send the job to the printer.

Table 6-1 Selectable options and their effects



| Option | Effect |
|--------------------------------------------------------------------------------------------------------------|-------------------------------------------------------------------------------------------------------------------------------------------------------------------------------------------------------------------------------------------------|
|  <p>OVERFLOOD</p> | Overflood: White ink is printed on the substrate, enabling you to print color on top of a non-white or translucent substrate. |
|  <p>UNDERFLOOD</p> | Underflood: The white layer is printed on top of the color layer, enabling you to create new colors by playing with white ink translucency. This is used to print on transparent substrates such as acrylic, transparent film, or glass. |
|  <p>SPOT</p> | Spot: White ink is printed in the same way as any other color. |

Table 6-1 Selectable options and their effects (continued)

Option

Effect

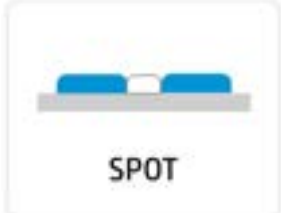

Sandwich: A white layer is embedded between two different images, allowing a different image to be seen on each side of the shape.

Water tank

Before printing with white ink, make sure that the water tank is full of distilled water.

To refill the water tank:

1. Pull out the tank.

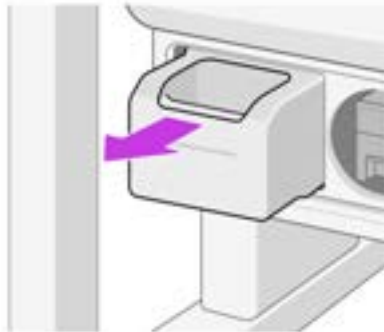
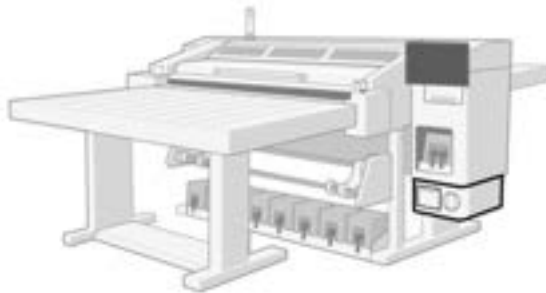

2. Remove the cap and refill the tank with distilled water up to the line.

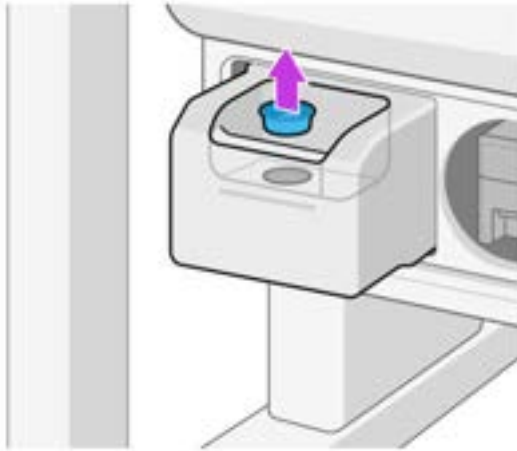

3. Put back the cap and close the tank.

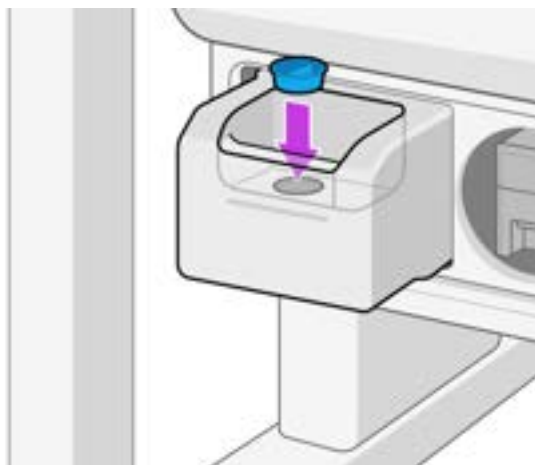

4. Put the tank back into place.

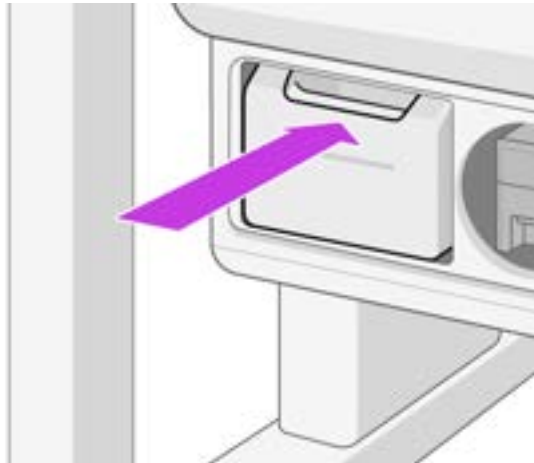

White-ink best practices

These best practices will help maximize ink and maintenance-cartridge efficiency.

Ink efficiency and productivity optimization

How to make efficient use of your white ink.

- Do not insert and extract the white printheads into/from the carriage more than once a day.
- Remember to group all the white jobs of the day in one run.
- Remember to insert the two white printheads always in the same position, otherwise the replacement time may be increased.
- Use the print mode with the minimum number of passes that satisfies your print-quality requirements.
- Use as much of the printer's width as possible for every job and nesting composition. You can save printing time and ink this way, because printing along the biggest side will minimize the number of passes necessary to complete the print.
- Use the warm-up button (available in the RIP) as recommended.

Printhead maintenance

How to maintain your white printheads for best performance.

- The printer should remain powered on at all times.
- Always follow the correct printhead replacement procedure in the printer. Failing to do so will affect printhead life and may void the white printhead warranty.
- Keep maintenance tasks up to date. White printheads are the most sensitive of the printhead types, so they will be the first to suffer if the printer is not properly maintained.
- Leave the white printheads in the wheel at night and when they are not going to be used. General rules depending on usage:
 - Occasional or moderate white ink usage (no more than 2 days per week):

Maintain white printheads in the offline rotation chamber and extract them only for printing white ink. Remember to extract printheads when there is a long color job or two or more short jobs.

- Heavy white ink usage (3 or more days per week):

Maintain the white printheads in the carriage. Extract them on weekends, when the printer will not be used, or when there is a long color job or two or more short jobs.

When the auxiliary printheads are going to be stored in the rotating chamber, follow these recommendations:

- Remove the printheads from the carriage carefully, placing a cloth below the needle to prevent ink droplets from falling on top of the carriage.
- Check the bottom plate of each white printhead. If there is any ink on it (which can happen because of the automatic recirculation), dampen a soft, fiber-free cloth with distilled water and let the printhead sit on it for a couple of minutes.



- Whenever you remove a printhead, check whether the FI tower (B in the picture below) has a lot of ink on it. If so, clean it with a lint-free cloth before inserting a new printhead.



- Clean the plastic needles of the rotating chamber if they have dry ink on them.

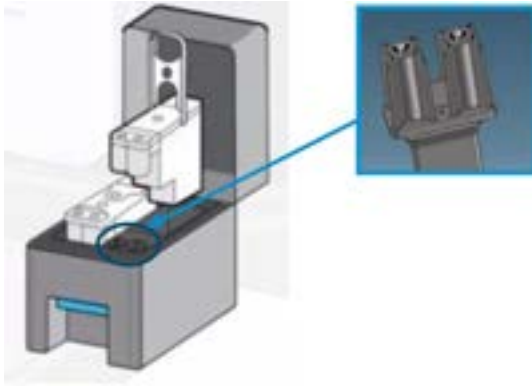

- Always store your printheads in the same rotating chamber slot.

Auxiliary printheads should be kept in the wheel, so they are capped, when not in the printer. If damaged, ink recirculation may be impacted, creating print-quality and/or reliability issues.

In the event of any print-quality issues, perform a nozzle check to see which printhead is causing the problem. **There is no need to change both printheads at the same time;** the problem may be caused by only one printhead.

Take care of your Eco-Carton ink cartridges

Follow these recommendations to keep your white-ink cartridges in good condition.

- Do not use expired ink.
- Before inserting a new cartridge, **always** shake it according to the instructions:
 - 60 times for 3-liter cartridges
- Never attempt to remove a white cartridge when the printer is performing self-maintenance.

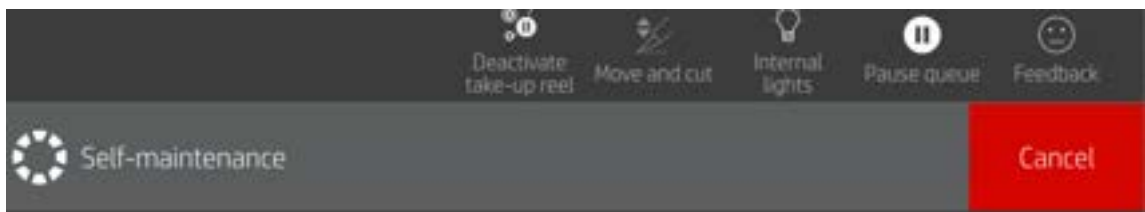

Print quality

How to maintain the quality of your prints.

- If you notice print-quality issues, print the diagnostic plot.
- If you have nozzle health issues, run a hard clean recovery of the affected printheads (this can be identified in the nozzle check plot). If the printhead does not recover, clean it gently with a soft, fiber-free cloth dampened with distilled water.
- Align the printheads on supported substrates.

7 Printer calibration

The following sections provide details for this topic.

Align the printheads

The printer requests a printhead alignment whenever printheads are replaced. If no substrate is loaded when a printhead is replaced, the printer will request to perform the alignment the next time you load substrate.

You may also be recommended to align the printheads to solve a print quality problem. In the picture below it is depicted the recommendation workflow that should be followed to align the printheads.



Automatic alignment

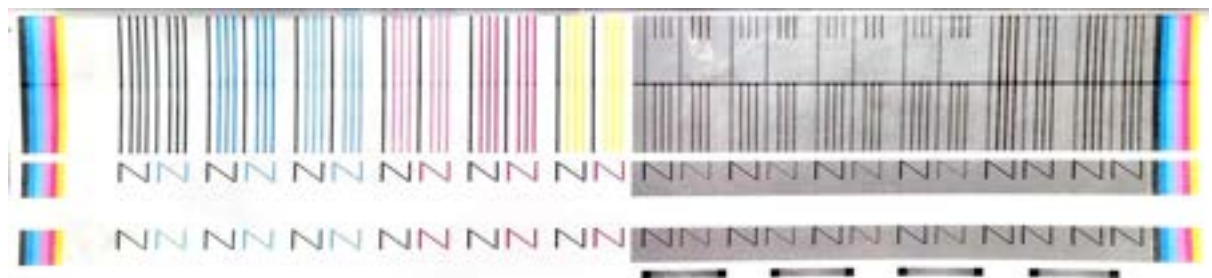

First make sure that you have a roll of opaque, white self-adhesive vinyl loaded in the printer. Colored substrates, glossy canvas, coarse textiles, and transparent materials are not suitable for automatic printhead alignment.

For these substrates, you should align the printheads manually (see [Manual alignment on page 127](#)) or perform the automatic alignment on a supported substrate of similar thickness first, then change to the special substrate. Alignment settings are retained through substrate changes until a new printhead alignment is performed.

To request printhead alignment (if the alignment is not performed automatically), tap **Printheads** > **...** > **Align** > **Automatic** > **Color** > **Print**.

The process takes about 9 minutes and starts immediately, unless an image is currently being printed. If a print job is in progress, the alignment will be done as soon as the current print job is finished.

Manual alignment

You can request a manual printhead alignment from the control panel. This procedure involves both color and white printheads, provided that both are installed in the printer when the calibration is triggered.

To request a manual printhead alignment from the control panel, tap **Printheads** > **...** > **Align** > **Manual** > **Print**.



The printer prints 46 color patterns, from A1-A2-A3 to P1-P2-P3. Each letter of the pattern represents a printhead, and the number is related to the calibration type: printhead to printhead scan and media axis, and bidirectional in scan axis.

Patterns "A" and "I" refer to Optimizer and Overcoat fluids respectively.

Patterns "H" and "P" refer to white printheads. Note that if white printheads are not installed, these patterns will not be printed.

Inspect the patterns and, if any correction is needed following the 'Legend of Errors and Correction values' section, apply them in the control panel.

To enter the correction values at the control panel you need to be in the manual alignment menu, **Printheads** > **...** > **Align** > **Manual** and the screen will show the values. Enter each value into the window labelled with the same letter-number as the corresponding pattern.

 **NOTE:** To check the new alignment status after applying the corrections entered, you can reprint the alignment status plot from the same menu.

HP does not recommend attaching the substrate to the take-up reel when running any printer calibration.

Color calibration

Color calibration enables your printer to produce consistent colors with a particular substrate type, even if printheads, ink cartridges, and environmental conditions change.

Color calibration sets the ink restriction and linearization, which varies with the drop weight of the printhead. This calibration has been designed to provide consistency as the printhead ages (drop-weight degradation) and from one printer to another. For example, to reach a maximum cyan density of 0.6, one printhead may require 3 drops while another one may require 3.5 drops (lower drop weight).

For generic substrate profiles, there are no factory-reference color-calibration values in the printer or within the presets: the first calibration for each substrate sets the color reference for future calibrations. The future calibrations will therefore try to match the colors of the first calibration. In this way you maintain consistency as the printhead ages.



Good nozzle health is important, and the printheads should also be as new as possible for best performance when you make the first calibration.

It is also important to have the printheads well aligned (see [Align the printheads on page 126](#)), and to make sure the substrate is advancing correctly, otherwise the color pattern may appear blurry or with slightly different colors.

 **NOTE:** Substrates can be color-calibrated only if they are cloned, white, opaque, non-porous, and wider than 61 cm (24 in).

For rigid substrates

The following steps provide the complete procedure for this topic.



1. To start color calibration from the Internal Print Server, tap  **Substrate library** in the app bar, and select the substrate you want to calibrate from the list on the left. Once you can see your substrate in the center of the screen, tap , then **Edit > Print color reference**, and the color calibration starts.
2. When the test chart has been printed, tap **Load or scan color reference**, and load the printed chart into the printer.

 **TIP:** It is best to reload the chart in the same position as it was when you printed it. To do so, you are recommended to enable the automeasure option in both cases.

For flexible substrates

The following steps provide the complete procedure for this topic.



- To start color calibration from the Internal Print Server, tap  **Substrate library** in the app bar, and select the substrate you want to calibrate from the list on the left. Once you can see your substrate in the center of the screen, tap , then **Edit > Print color reference**, and the color calibration starts.

Further Color Calibration Information

The following steps provide the complete procedure for this topic.

 **IMPORTANT:** To calibrate a flexible substrate, you must calibrate a roll on a roll rewinder, not just a loose sheet of flexible substrate.

 **NOTE:** Color calibration is not recommended when the carriage beam is in a higher position than normal.

The calibration process is fully automatic and can be performed unattended after you have loaded substrate of the type you wish to calibrate. The process takes about 15 minutes and consists of the following steps:

1. The color calibration test chart is printed, which contains patches of different densities of each ink used in your printer.



2. The test chart is scanned and color-measured using the embedded spectrophotometer. If the scan cannot be completed successfully, a message is displayed by the Internal Print Server; see [Color calibration on page 127](#).
3. From the measurements made by the spectrophotometer, the printer calculates the necessary correction tables to apply to your print jobs for consistent color printing on that substrate type—except in the case of the first calibration, which sets the reference for later ones.

Calibration should be done in any of the following circumstances:

- Whenever a new substrate type is introduced that has not yet been calibrated: to set the reference.
- Whenever you notice excessive color differences between prints. Such color differences can be caused by aging and wear of the printheads, installing new printheads, changes in substrate characteristics between one roll and another, changing environmental conditions, and so on.
- **Default** status indicates that this substrate has never been calibrated, and therefore no reference state is defined.
- **Done** status indicates that a color calibration has been performed successfully on this substrate, the reference state is defined and still up to date.
- **Obsolete** status indicates that the printer status has changed since the reference was defined, so a new calibration must be done in order to maintain color consistency.

Color calibration is based on the color measurement of printed color patches, using the embedded spectrophotometer. Some characteristics of substrates, such as surface roughness or transparency, may make reflective color measurement of some substrate types very inaccurate. Color calibration of these substrates may fail or produce unacceptable printing results.

 **TIP:** If color calibration fails at the first attempt, it is worth trying again.

To delete the reference for a given substrate, so that you can create a new reference for that substrate, you must clone the substrate. The new substrate will have no color reference.

You should calibrate a substrate type before creating its color profile; however, you can later recalibrate without needing to recreate the color profile.

ICC profiles

Color calibration provides consistent colors, but consistent colors are not necessarily accurate. For instance, if your printer prints all colors as black, its colors may be consistent but they are not accurate.

In order to print accurate colors, it is necessary to convert the color values in your files to the color values that will produce the correct colors from your printer, your inks, your print mode, and your substrate. An ICC profile is a description of a printer, ink, print mode, and substrate combination that contains all the information needed for these color conversions.

These color conversions may be performed by your Raster Image Processor (RIP), if it offers that possibility; they are not performed by the printer. For further information on the use of ICC profiles, see the documentation for your application software and for your RIP.

In addition to the ICC profiles used for printing, you may wish to calibrate and profile your monitor (display device), so that the colors you see on the screen relate more closely to those that you see on your prints.

Recommended calibrations after particular events

This topic provides a full set of reference information for this subject.

Table 7-1 Recommended calibrations after particular events

| - | Printhead replacement | New substrate created | New substrate imported | New substrate loaded | Print mode changed | Poor print quality |
|----------------------------|-----------------------|---------------------------------------------------------|------------------------|-------------------------------------------|--------------------|-------------------------|
| Printhead alignment | Recommended | Not needed unless new substrate has different thickness | Not needed | Not needed unless carriage beam has moved | Not needed | Recommended if relevant |
| Color calibration | Recommended | Recommended | Recommended | Not needed, unless never done before | Not needed | Recommended if relevant |

Color consistency between different HP Latex R series printers

The following steps provide the complete procedure for this topic.

It is possible to print consistent colors on different HP Latex printers by exporting a calibrated substrate preset (see [Substrate presets on page 80](#)) from one calibrated printer to another. This process ensures that both printers use the same color references.

1. Create the reference for the first printer: do at least the first color calibration with the substrate in question.
2. Export the substrate preset from the first printer. The reference is also exported.
3. Import the substrate preset to the second printer.
4. Perform color calibration with the same substrate for the second printer, to make it consistent with the reference imported with the preset.

Now both printers have the same reference for the same substrate, and all the consecutive color calibrations will be trying to match this reference state.

8 Printer maintenance

For the tasks in this chapter, you may need the user maintenance kit that was provided with your printer.

General cleaning instructions

The information provided here details the best practices regarding general cleaning of the printer.

- For general cleaning, a lint-free cloth dampened with distilled water is recommended. Let the cleaned part dry or use a cloth to dry it completely.

Do not spray fluids directly onto the product. Spray the fluid onto the cloth used for cleaning.

- To remove stubborn dirt or stains, moisten a soft, fiber-free cloth with water and a neutral detergent, or general-purpose industrial cleaner (such as Simple Green industrial cleaner). Remove any remaining soap foam with a dry cloth.
- For glass surfaces, use a soft, lint-free cloth lightly moistened with a non-abrasive glass cleaner or with general-purpose glass cleaner (such as Simple Green glass cleaner). Remove any remaining soap foam with a lint-free cloth dampened with distilled water, and dry it with a dry cloth to prevent spotting.

 **CAUTION:** Do not use abrasives, acetone, benzene, sodium hydroxide, or carbon tetrachloride on the glass; they can damage it. Do not place or spray liquid directly onto the glass: the liquid could seep under the glass and damage the product.

- HP recommends using a canister of compressed air to remove dust from electronic and electrical parts.

 **CAUTION:** Do not use water-based cleaning liquids on parts with electrical contacts, which could cause damage.

 **CAUTION:** Do not use wax, alcohol, benzene, thinner, ammonia-based cleaners, or other chemical detergents, to prevent damage to the product and to the environment.

 **NOTE:** In some locations the use of cleaning products is regulated. Ensure that your cleaner follows federal, state, and local regulations.

Maintenance tools recommended but not provided

The information provided here details the recommended tools the user should provide for maintenance of the printer.

Table 8-1 Maintenance tools recommended but not provided (I)

| Folding steps, for general use | Vacuum cleaner, handy or normal, with nozzle accessories | Flashlight, for general use |
|-----------------------------------------------------------------------------------|-----------------------------------------------------------------------------------|-------------------------------------------------------------------------------------|
|  |  |  |

Check and clean the printheads

Check the printheads routinely before going into production.

1. Go to the Internal Print Server and tap the printhead widget, then **Check and clean**.



2. Tap the **Check** button to perform routine cleaning automatically.

The check-and-clean process checks the printheads, recovers the ones with blocked nozzles, and replaces the nozzles that are not recovered with healthy ones for printing. If the missing nozzles have not been recovered, tap **Hard cleaning**.

 **NOTE:** You can minimize wasted ink by performing the check-and-clean operation just before starting production.

Clean the electrical connections on a printhead

It is possible that the printer will not recognize a printhead after it has been installed. This can happen when ink builds up on the electrical connections between the printhead and the printhead carriage.

Under these circumstances, HP recommends that you clean the electrical connections on the printhead. However, routine cleaning of the connections when no problems are apparent is *not* recommended.

A carriage interconnect wiper is included with your printer in the user maintenance kit.



Use this to clean the electrical interconnects on both the printhead carriage and the printhead if the **Reset** or **Replace** message persists next to the printhead on the control-panel display.

 **TIP:** You are recommended to wear gloves.



1. Remove a new pre-moistened replacement sponge from its pouch.

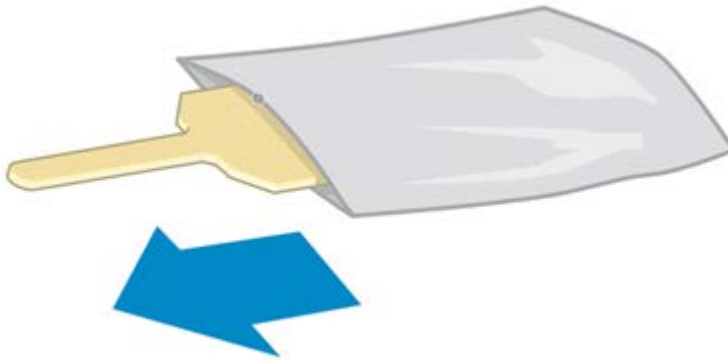

A supply of sponges is included in the box with the wiper. If all sponges have been used, more can be obtained by calling your service representative.

2. Open the carriage interconnect wiper.

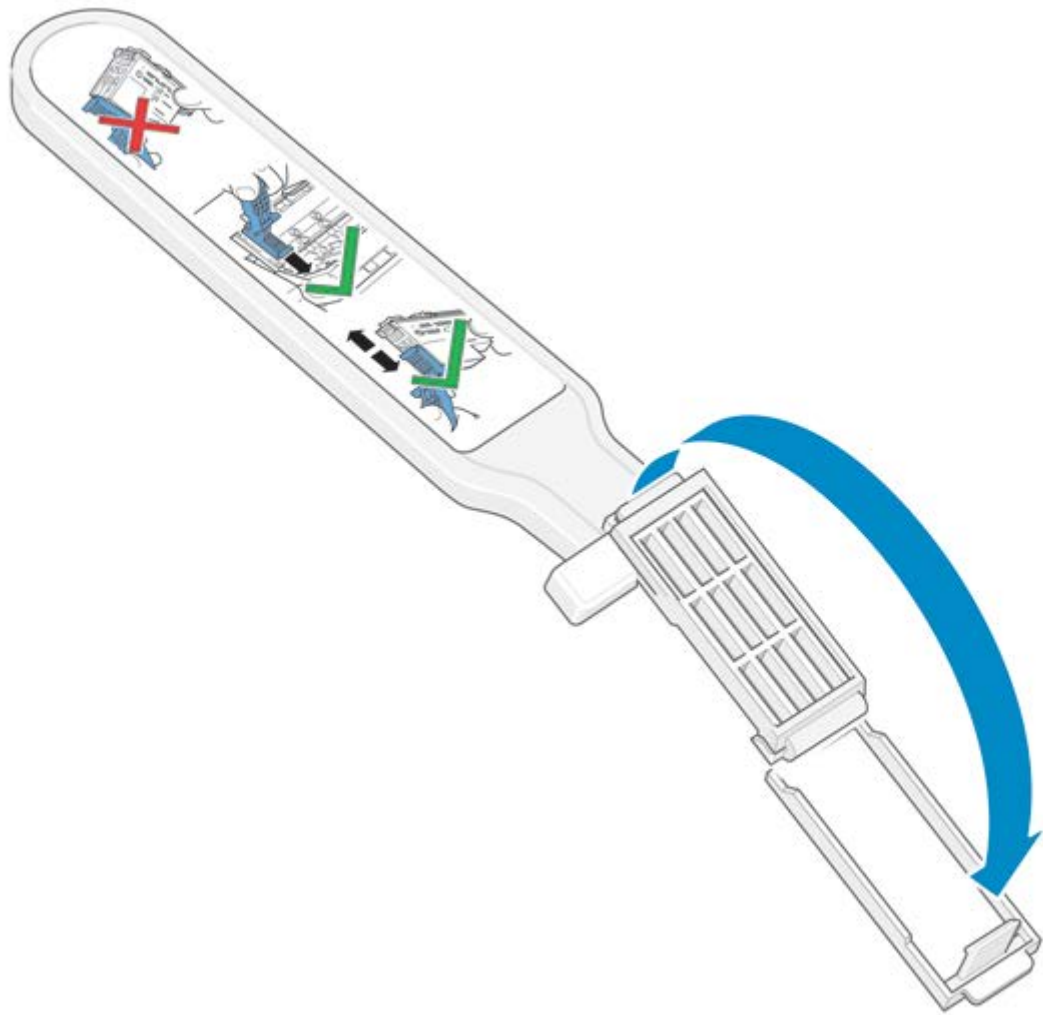

3. Load the sponge by positioning the sponge on the face of the carriage interconnect wiper with the shorter tab in the locating slot.

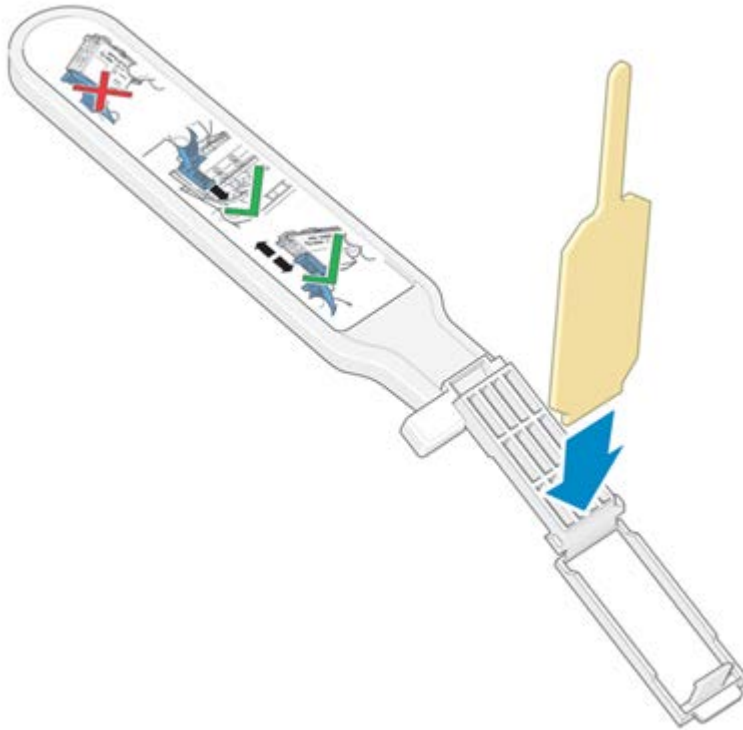

4. Close the carriage interconnect wiper, trapping the sponge in place.

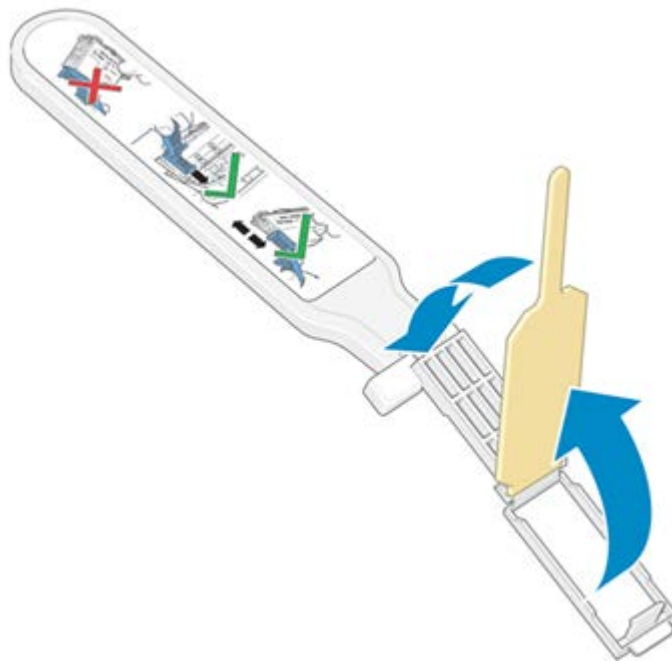

5. Open the printhead carriage latch and extract the printhead that is causing the problem, as indicated on the control panel. See [Replace a printhead on page 98](#).

6. Insert the carriage interconnect wiper into the printhead slot at the back. Wipe the electrical contacts by inserting the tool between the electrical connections at the back of the slot and the steel spring, with the sponge facing away from you and towards the electrical contacts. Try to avoid picking up any ink deposit that may have accumulated on the bottom surface of the slot.

⚠ CAUTION: If the carriage remains in the central part of the printer for more than 7 minutes, it attempts to return to its home position to the right.



7. Rub the sponge against the contacts with a *light* force along the entire depth of the flex connector, inserting the wiper as far as allowed by the mechanical stop on the tool.

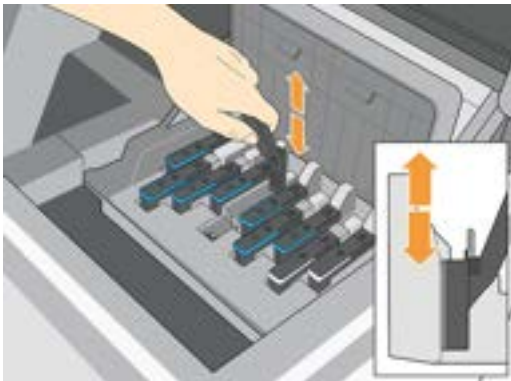

8. Take special care to clean all contacts thoroughly, including the ones at the lowest point of the connector.

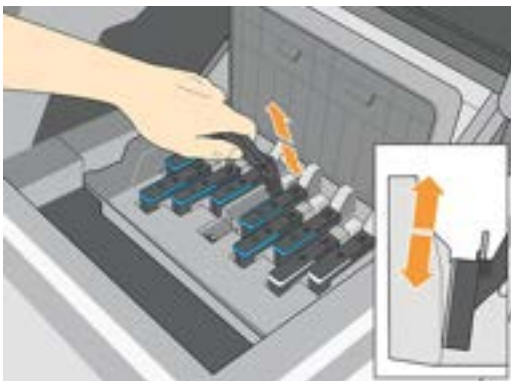

- Using the same sponge, clean the lower strip of electrical contacts on the printhead (unless the printhead is new). Avoid touching the upper set of electrical contacts.

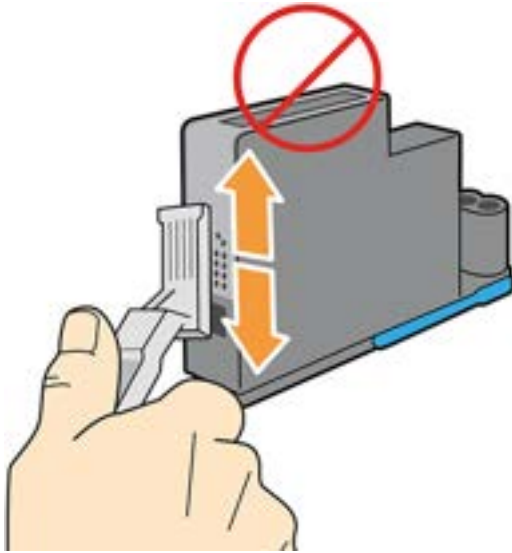

CAUTION: Do not touch the surface of the printhead that contains the nozzles, because the nozzles are easily damaged.

- After waiting a few moments to allow both connectors to dry, replace the printhead into the printhead carriage. See [Replace a printhead on page 98](#).
- After completing the cleaning process, open the carriage interconnect wiper by pulling on the sponge tab.



12. Remove the soiled sponge from the carriage interconnect wiper.

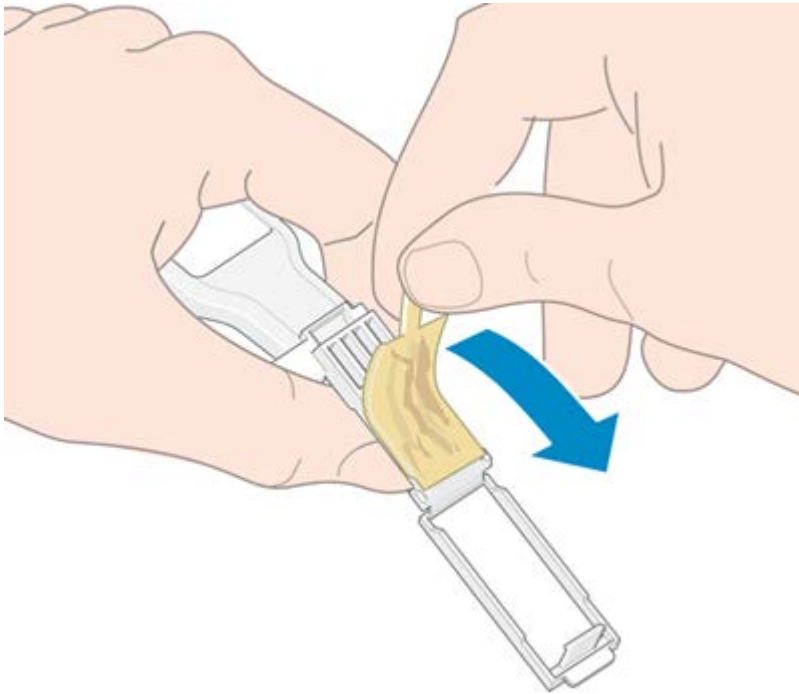

13. Dispose of the soiled sponge in a safe place to prevent the transfer of ink onto hands and clothing.

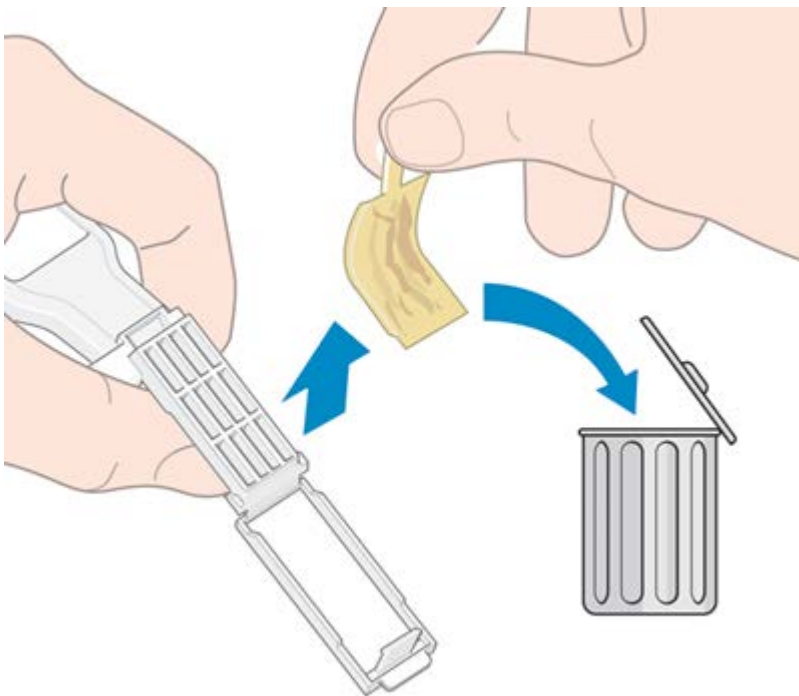

If the control panel continues to show the **Reset** or **Replace** message, replace the printhead or call your service representative.

Clean and lubricate the printhead carriage rod

Perform this maintenance operation if you see the error 0086-0003-0079, which is caused by scan-axis motor friction.

 **NOTE:** In some circumstances, such as in ambient temperatures above the printer's operational specification (see [Environmental specifications on page 223](#)), or if there is a significant amount of dust in the air, the lubrication of the slider rods may be impaired, which can affect the performance of the printer.

 **CAUTION:** The printheads may be damaged if left uncapped for a long period. Therefore, HP recommends completing this process and restarting the printer within 10 minutes.

1. If substrate is loaded, unload it.
2. Select **Maintenances** to display the list of available procedures.
3. Select the "Clean and lubricate the carriage rod" maintenance to view the instructions.
4. Turn the print zone light on, then lift the curing module.
5. Clean the printhead carriage rod with a clean cloth, ensuring the entire rod is cleaned, including the section under the left cover.

 **CAUTION:** Do not use commercial cleaners or abrasive cleaners.

 **WARNING!** Avoid moving parts. You are recommended to wear gloves.

 **NOTE:** While cleaning, be careful not to damage the plastic encoder strip located on top of the rod.

6. Take the bottle of oil from the user maintenance kit supplied with your printer. Apply a very thin zig-zag trickle of oil along the rod.
7. Lower the curing module and press the button on the IPS to move the carriage to the left side.
8. Open the carriage cover and repeat steps 5 to 7.
9. Close the carriage cover and press the button on the IPS to move the carriage to the capping position.
10. Mark the procedure as done.

Clean the encoder strip

Cleaning the encoder strip is a vital part of the printer's maintenance and can clear a variety of system errors.

- 0086-0003-0059 or 0086-0010-0084 system errors and related mispositioning of the carriage assembly errors, such as the carriage bumping into the side of the printer.
- 0086-0003-0061 system errors, related to failures starting and homing the carriage on the scan axis.
- There are occasions when a dirty encoder strip can cause substrate loading issues, as the carriage cannot correctly detect the position of the substrate.

The encoder strip should be cleaned when requested by the printer.

 **IMPORTANT:** You should also clean the encoder strip after replacing the maintenance cartridge.

1. If substrate is loaded, unload it.
2. Select **Maintenances** to display the list of available procedures.
3. Select **Clean the encoder strip** maintenance to view the instructions.
4. Turn the print zone light on, then lift the curing module.
5. Clean both sides of the encoder strip underneath the curing module using a lint-free cloth moistened with distilled water. Ensure the strip is clean and repeat if necessary.

 **NOTE:** Do not use commercial cleaners or abrasive cleaners.

 **NOTE:** Avoid moving parts. You are recommended to wear gloves.

6. Lower the curing module and press the button on the maintenance panel to move the carriage to the left side.
7. Open the carriage cover and repeat step 5.
8. Close the carriage cover and press the button on the maintenance panel to move the carriage to the capping position.
9. Mark the maintenance as done.

Replace the rod oiler and felts

Performing this maintenance operation ensures smooth connection between the rod and the carriage, avoiding errors due to high friction when moving the carriage.

1. If substrate is loaded, unload it.
2. Select **Maintenances** to display the list of available procedures.
3. Select the **Clean and lubricate the carriage rod** maintenance to view the instructions.
4. Turn the print zone light on and press the button on the IPS to move the scan beam to the upper position.
5. Lift the curing module.
6. Clean the printhead carriage rod with a clean cloth, ensuring the entire rod is cleaned, including the section beneath the left cover.

 **CAUTION:** Do not use commercial cleaners or abrasive cleaners.

 **WARNING!** Avoid moving parts. You are recommended to wear gloves.

 **NOTE:** While cleaning, be careful not to damage the plastic encoder strip located on top of the rod.

7. Lower the curing module and press the button on the maintenance panel to move the carriage to the left side.

8. Open the carriage cover and repeat step 6.
9. Close the carriage cover and press the button on the maintenance panel to move the carriage to the oiler replacement position.
10. Lift the curing module and the carriage cover.
11. From the left side of the carriage, pull the edge of the metal lever and rotate it a quarter turn clockwise.

When operating in this area, be careful not to damage the plastic encoder and the crash sensor.

12. Once the oiler is released, first move it to the left and then pull it to detach it from the rod.
13. Install the new oiler by repeating step 12, then step 11 (in reverse). Ensure the metal level remains in the correct closed position.
14. From the carriage's right side, manually remove the thumb screw.

 **NOTE:** Place a piece of paper under the right felt to catch any component that may fall.

15. Pull out the felt retainer and remove the lubrication felt.
16. Install the new felt by repeating step 15, then step 14 (in reverse).
17. Take the bottle of oil from the user maintenance kit supplied with your printer. 7. Apply a very thin zig-zag trickle of oil along the rod.

While lubricating, be careful not to drop oil on the encoder strip located on top of the rod.

18. Lower the curing module and close the carriage cover.
19. Press the button on the IPS to move the carriage to the left side. Once stopped, press the button on the IPS to move the carriage to the capping position.
20. Clean the encoder strip on both sides underneath the curing module with a lint-free cloth moistened with distilled water. Ensure the encoder strip is clean. Repeat the process, if necessary.

 **NOTE:** Do not use commercial cleaners or abrasive cleaners.

 **NOTE:** Avoid moving parts. You are recommended to wear gloves.

21. Lower the curing module and press the button on the IPS to move the carriage to the left side.
22. Open the carriage cover and the repeat the step 21.
23. Close the carriage cover and press the button on the IPS to move the carriage to the capping position.
24. Press the button on the IPS to move the scan beam to lower position
25. Mark the maintenance as done.

Replace or empty the condensation collector

If the condensation collector needs replacing or becomes full, perform this procedure.

The condensation collector should be replaced or emptied in the following situations:

- When the printer shows a condensation-collector alert on the control panel.
- When the condensation collector has reached its capacity: see the level indicator on the collector.

1. Go to the IPS and select **Other** supplies, then scroll down to **Condensation collector**.

2. Tap the **Empty** button. The control panel explains how to proceed.

You are recommended to wear gloves.

3. When the ink collector has been emptied, tap **OK**, and remember to reset the counter by tapping the **Reset** button.



4. The control panel asks you to confirm that the condensation collector level will be reset.



Check and clean the plastic needles in the printhead slot

HP recommends cleaning the plastic needles once a month.

1. Remove the storage box from the storage system.

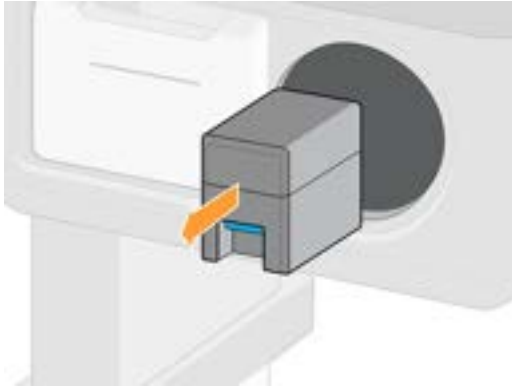

2. Open the storage box and remove the printheads inside (auxiliary or white printheads).

⚠ CAUTION: HP recommends performing these operations without pausing, otherwise needles are left exposed to the air and the ink may dry out. It is best to do the maintenance when the printheads are installed on the carriage.

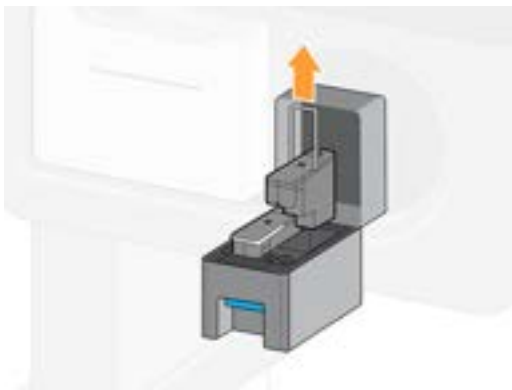
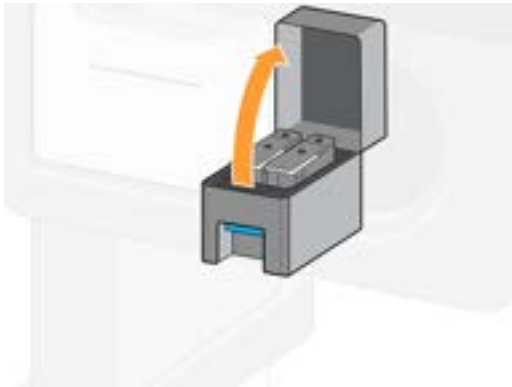

3. Check the plastic needles and clean off any ink remaining on them with a soft, fiber-free cloth dampened with distilled water.



4. With a dry cloth, dry the remaining water on the plastic needles.
5. Put the printheads into the storage box.

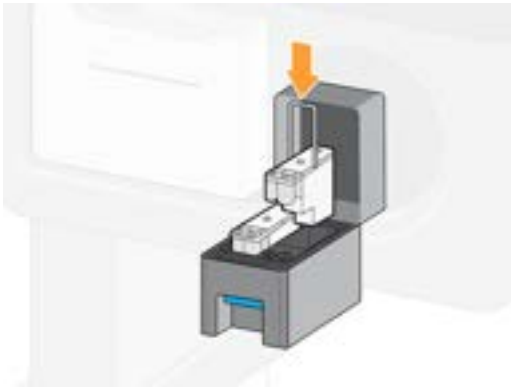

6. Put the storage box back into the storage system.

Replace the plastic needles in the printhead slot

Needles should be replaced only when damaged.

CAUTION: The screws should not be reinstalled more than three times.

1. Remove the damaged plastic needle by pulling it from the top with pliers.

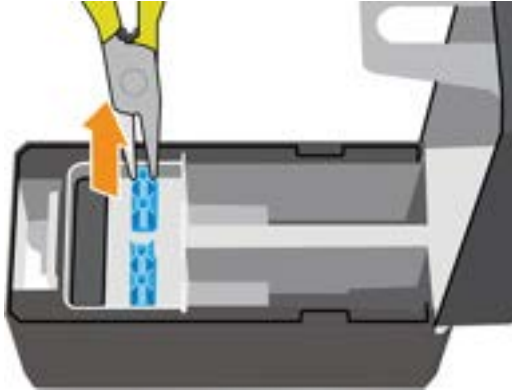

2. Remove the six screws from the bottom part.

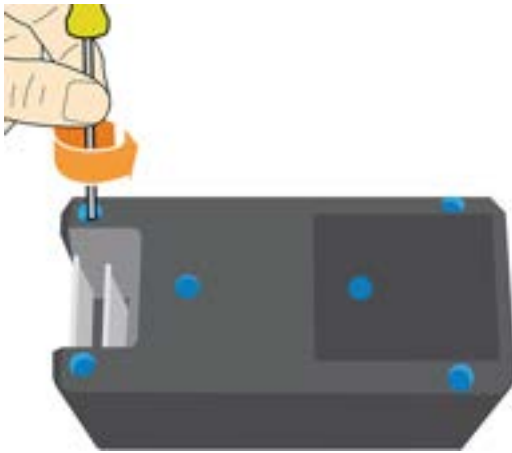

3. Take a new plastic needle from inside the plastic part or from the user maintenance kit.

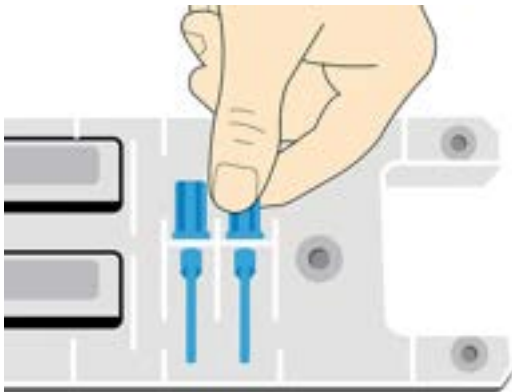

4. Insert the new plastic needle from the top, and pull it from below with pliers.



5. Assemble the plastic part and reinstall the six screws.

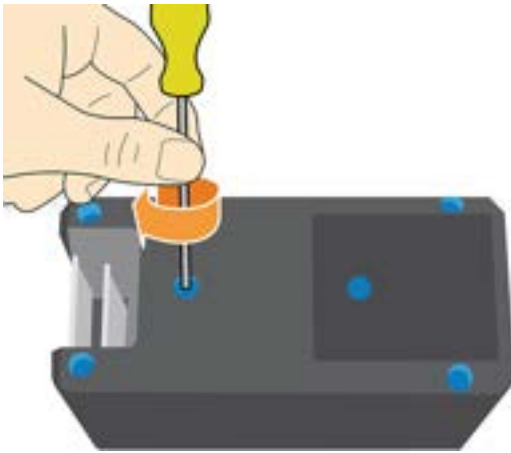

Clean the exterior of the printer

Use a damp sponge or a soft cloth and a mild household cleaner such as non-abrasive liquid soap to clean the outside of the printer and all other parts of the printer that you regularly touch as part of normal operation.

There may be some dampness from condensation under the fans of the curing module, which should be wiped with a dry cloth.

⚠ **WARNING!** To avoid an electric shock, make sure that the printer is turned off and unplugged before you clean it. Do not let water get inside the printer.

⚠ **CAUTION:** Do not use abrasive cleaners on the printer.

Curing user maintenance

Periodic maintenance for the curing every 50 liters to ensure optimal performance.

📄 **NOTE:** If this maintenance is not performed, curing performance may decline until the **curing maintenance (PMK14)** is completed.

For impinging cleaning, follow these instructions:

1. Unload all substrate from the printer. For more information, see [Unload a roll from the printer on page 62](#).
2. Turn off the printer.
3. Lift the curing module.
4. Use a vacuum cleaner (minimum 1000 W power) to clean the impinging plate from the lower part of the curing module.



5. Clean the impinging two times per module, using the sequence shared in the image below.



6. Repeat the previous step for all module areas.

7. Pay special attention to cleaning the riveted area of the impinging plate, as most curing defects start there (see image below).

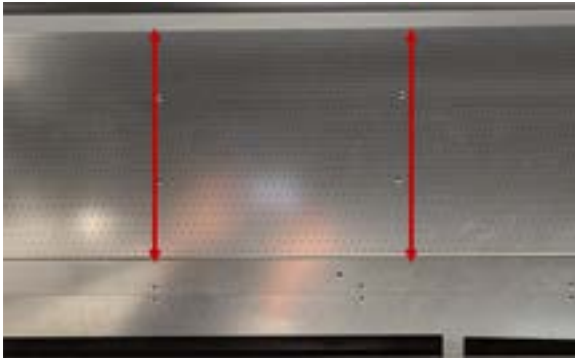

Clean the curing modules

The control panel indicates when the curing modules need cleaning, which is important to provide correct curing.

The cleaning will be done by your service representative if the printer is within warranty or under a specific service contract.

NOTICE: HP is not responsible for any injuries sustained if its instructions for this operation are not followed.

Service maintenance

During the life of your printer, components that are used constantly can wear out.

Regular maintenance is critical to avoid these components degrading to the point that the printer breaks down. The printer keeps track of various parameters such as the line-sensor degradation, the number of cycles that the carriage makes across the axis of the printer, and the total quantity of ink used.

The printer uses these numbers to track the need for service maintenance, and displays one of the following messages on the control panel:

- **Maintenance block 150 liters**
- **Maintenance block 100 liters white ink**
- **Maintenance block 450 liters**

These messages mean that some components are nearing the end of their lives. You may be able to continue printing for a period of time, depending on your use of the printer. However, HP strongly recommends that you call your service representative and arrange for a service maintenance visit. The service engineer can then replace the worn parts on-site, which will prolong the life of the printer and enable continued, safe and optimized operation. Under some circumstances, if some of these maintenances are not performed, the printer may stop printing and you will not be able to send new jobs from the RIP. At that point, you will need to contact your service representative.

All these parts will be replaced preventively by your service representative if the printer is within warranty or under a specific support contract. During a service maintenance visit, the service engineer replaces several parts at once, avoiding the need for repeat visits.



NOTE: In order to be able to replace the different parts before they reach their end of life, the printer must be connected to the Internet and the PDSA must be accepted.

9 Software updates

The printer's functions are controlled by software residing in the printer (firmware) and on the IPS computer (Internal Print Server).

HP periodically provides firmware and software updates to enhance functionality and features.

IMPORTANT: HP recommends an external LAN connection for this procedure, as it allows you to automate some procedures, and simplifies the process. The following sections provide instructions for each situation.

TIP: When updating the firmware and the Internal Print Server, first update the firmware and then the Internal Print Server.

Automatic firmware and software updates

When a LAN connection is available, the Internal Print Server periodically checks whether a new update package has been published by HP.

If a new update is available, it is automatically downloaded and presented in the Internal Print Server as a "New firmware and software release", visible in the Maintenances window.

When the Internal Print Server computer is started for the first time, it takes a few minutes to download the update package and display the notice in the Maintenances window.

1. Select **Maintenances** to display the list of maintenances.

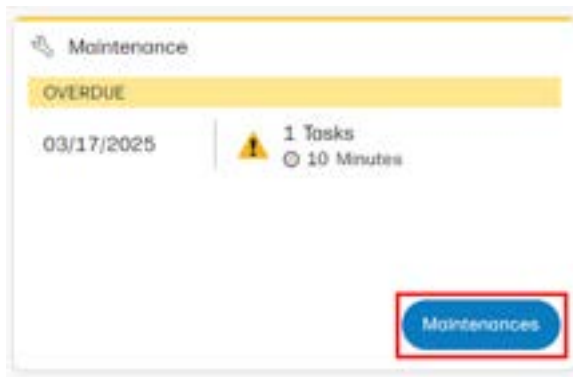

2. Select **New firmware and software release** to view the improvements and instructions.



3. Press **Update system**. The firmware update will begin first, followed by the automatic launch of the Internal Print Server installer. Follow the on-screen instructions to complete the process.



Once the printer is updated, it will restart automatically. The IPS computer will also restart as a last step of the software update.

NOTE: Do not proceed with the update if a severe error is present.

NOTE: If there are any failures during the process, installer files can be obtained from:
C:\ProgramData\HP\IPS\maintenances\ASU\resource

Manual firmware and software updates

The system may be manually updated for any reason, typically when it has no LAN connection.

IMPORTANT: The firmware update is only allowed in normal boot mode. Do not attempt to update in diagnostic mode or any other mode unless instructed by your service representative.

Firmware, Internal Print Server, and maintenance updates can be downloaded from the Internet and installed in your printer using the Internal Print Server.

1. Download the latest update files from the hp.com website onto your computer's hard disk (preferably in a dedicated folder, not on the desktop) and unzip all the files. You will find three

files: a firmware package (*.fmw), an Internal Print Server installer (HPIPS*-installer.exe) and a maintenance installer (HPIPS*-Maintenances.exe).

 **NOTE:** The download from hp.com may consist of several compressed files, such as *.zip, *.z01, etc. Once downloaded, extract the content using a file compression utility (do not use the built-in Windows utility).

2. Copy the three files to a USB device, placing them in the same folder. Plug the USB device into the socket on the Internal Print Server computer.
3. At the bottom of the Internal Print Server's home screen, press the **About** icon  to open the **About** window.



4. Select **Update firmware**.



 **IMPORTANT:** The firmware update not be executed if the printer is in a severe error state.

5. A file browser window opens. Navigate to the USB device and look for the firmware update file. Press **Select**.



6. The firmware is uploaded to the printer. A progress bar is displayed while it is uploading.



7. On completion, the Internal Print Server displays a message confirming the update. Select **OK** to continue. At this point, the printer should restart without any interaction. If it does not, restart the printer manually.

NOTICE: The first restart after the firmware update may take longer than usual.

8. Back in the **About** window, select **Update IPS**.



9. A file browser window opens. Navigate to the USB device and look for the IPS update file. Select **Open**.



10. The IPS app closes and the installer starts. Follow the onscreen instructions until the new Internal Print Server is installed.

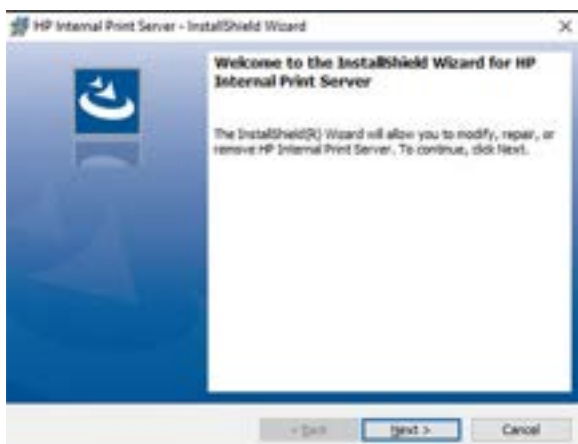

11. If the maintenance update file is in the same folder as the IPS update file, the Internal Print Server installer also installs the maintenance update. However, if you need to install the maintenance update separately for some reason, you can do so as follows.
 - a. Back in the **About** window, select **Update maintenances**.
 - b. A file browser window opens. Navigate to the USB device and look for the maintenance update file. Press **Select**.
 - c. The maintenance installer starts. Follow the onscreen instructions until it finishes.

 **NOTE:** After updating the HP Internal Print Server, the software will boot up automatically. If it does not, first select the HP Internal Print Server and HP Internal Print Server Front End icons.

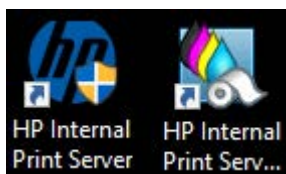

12. On the first boot, the Printer Data Sharing Agreement (PDSA) window will appear. Click **Accept** to continue.

HP strongly recommends accepting the agreement to take advantage of the Information Retriever functionalities and to ensure a faster and better remote support experience.

Large Format Privacy Notice

Connected printing services

When your printer is paired with HP services, HP collects data from the printer:

- Required to support features, functions, and services under your company's contract with HP or with an authorized third party.
- To improve the performance and operation of products, solutions, services and support, including warranty support and timely firmware and software updates, and alerts to ensure the continued operation of the printer or service(s).

HP does not access the content of any shared or printed files.

Any personal data collected by HP will be subject to [HP's Privacy Statement](#) and [HP's Data Processing Addendum](#).

Cancel

Accept

10 Troubleshoot substrate issues

Substrate issues may include various deformations of the substrate, as well as jams during printing and issues with the take-up reel.

Loading issues

A substrate cannot be loaded unless all printer subsystems (such as the ink system) are ready. If the Internal Print Server displays a message about loading errors, follow the on-screen instructions.

Loading issues in flexible media

The following sections provide details for this topic.

The flexible substrate is not attached to the core.

If the printer detects a lack of tension during the substrate check after loading, it will ask you to confirm the winding direction.

If the roll is not firmly attached during printing, you may see banding on your prints.

If you see an error message numbered 0041-0020-0084 or 0041-0020-0086 while printing, it means that the substrate may have become detached or the core is slipping on the roll rewinder. This could mean that you have reached the end of the roll, or there is a problem in the media input hub.

You should respond to this error in the following ways:

- Check whether you have reached the end of a roll.
- Check that the hub and the rubber are present and undamaged.

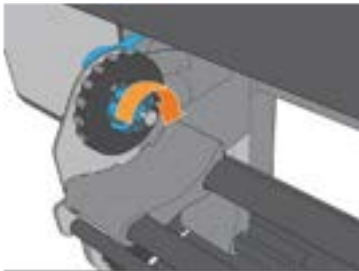

There is skew or telescoping on the take up reel

The following sections provide details for this topic.

Extreme skew (approximately 10 mm peak to peak) and telescoping in the take up reel while it winds can be caused in three main ways:

- The substrate was not correctly loaded and aligned during the loading procedure.
- The roll loaded on the input rewinder is skewed, and this skew is transferred to the output.
- The roll loaded on the input rewinder has been wound with different tensions at its two ends.

Printing on rolls that are not wound accurately during manufacturing may lead to wrinkles and skew problems. This issue is usually easy to identify as there will be a loss of tension on one side of the substrate between the input roll and the main roller.

 **TIP:** Generally, the main contributor to skew is an imprecise substrate load, and the effects of that are worse with wide rolls. However, if you have some skew or telescoping but this does not affect your print quality, and does not generate wrinkles in the substrate, there is no need to take any action.

 **IMPORTANT:** HP recommends using the automatic de-skew process in all roll loads.

Avoiding skew is also important to not exceed the maximum allowed weight:

- 30 kg if width \leq 42in
- 40 kg if 42 in < width \leq 54 in
- 55 kg if 54 in < width \leq 64 in

Loading issues in rigid media

If the printer is unable to load the substrate correctly, it may be due to one of the following reasons:

Excessive weight

If the substrate is too heavy, the printer may not be able to pull it in.

Possible solutions

- Ensure the substrate meets the maximum weight specifications outlined in the printer's technical documentation.
- Increase the vacuum level in the loading area to improve grip.
- Increase the surface area covered by the conveyor belt to enhance traction.

Lack of flatness in the loading area

If the substrate is not lying flat in the loading area, the conveyor belt and vacuum system may not function correctly.

Possible solutions

- Ensure the substrate is resting properly on the conveyor belt.
- Check that the loading tables are correctly aligned with the loading surface.
- Verify that the entire length of the substrate is supported by the loading tables. If needed, add extension tables for additional support.
- If the issue persists, apply manual pressure during loading.

 **NOTE:** This may affect image registration,

- Alternatively, use the hold-down plate to improve traction. If using this method, ensure the substrate touches both the lateral bar and the alignment bar after installation.

Substrate fails to reach the print zone

If the substrate fails to reach the print zone, it may be due to pre-deformation of the sheet, causing it to get stuck when passing under the scan axis.

Possible solutions

- Verify that any material deformation during loading (in both shape and dimensions) complies with the established requirements.
- Ensure the material thickness is correctly specified in the IPS.
- Check that the alignment bar is in contact with the upper surface of the material and is capable of flattening it.

The substrate cannot be measured successfully

This topic explains the concepts involved in this subject.

- When using dark or transparent substrates, the line sensor cannot detect the substrate edges. You can enter the substrate's width and position manually into the Internal Print Server.
- If the alignment bar fails to measure the thickness of the substrate correctly, enter it manually into the Internal Print Server.

Print from pinch for flexible media

The printer can print from nearly the pinch position, minimizing media waste. After the loading workflow, the printer positions the leading edge of each media category optimally to avoid defects that could crash against the carriage.

Materials like banners, which are rolled inward, are placed farther from the pinch wheels to prevent crashes against the carriage.

After the loading process, the user can move the media. If moved closer to the pinch, ensure that the leading edge is clean and flat, as an irregular leading edge can cause jams.

Some materials (such as certain PVC banner brands or weights) may experience difficulties when printing from the pinch without tension on the leading edge, which could result in wrinkles in the first meter. In such cases, it is recommended to attach the leading edge to the TUR.

 **IMPORTANT:** Never attach the leading or side edge to the belt with tape or similar when using media from a roll. Performing a job deskew may damage the MI hardware.

Flexible substrate print-length troubleshooting

During the printing process, some substrates may shrink, while others may expand. If this happens, the dimensions of the print will not be correct.

As a general rule, you can expect the following percentages of shrinkage:

- Banners: less than 0.3%
- Self-adhesive vinyls: less than 0.2%

- Papers: expansion less than 0.3%

The framing problem may be solved by printing a sample and adjusting the size of the image in the RIP. You may reuse this value for all your future prints with the same substrate, although special care must be taken when using banners, as the shrinkage may vary up to 1% depending on the amount of ink used in the print.

If you need to print on a substrate susceptible to expansion:

- Ensure that the ink density is consistent across all tiles; otherwise, tiles with less ink may be shorter.
- If possible, decrease the heating temperature.
- Reduce the ink restrictions as much as possible.
- Ensure that the roll is left in the same room as the printer for at least 24 hours so it reaches the same temperature.
- Do not touch the print adjustments between tiles (no change of substrate advance compensation).

To print all tiles at once, we recommend the following:

- Create the tiles from the Internal Print Server
- If you are creating the tiles from the RIP, ensure that you send all the tiles within the same jobs sent to the printer/Internal Print Server.

The objective is to ensure there is no pause between the tiles. When using the **Queue** mode in the Internal Print Server, there is still a small gap between jobs, which could increase variability in the lengths of the tiles.

HP also recommends tiling together areas with similar amounts of ink. If this is not possible, print the areas with different amounts of ink as different jobs and modify the length of the job with less ink in the RIP to match its size with the job with high ink content.

The printer is able to have good tile repeatability printing from pinch. To maximize tile repeatability, advance the leading edge until the end of the belt, or attach it to the TUR.

Small length variations may occur mainly while the leading edge is not yet attached to the TUR. For this reason, and to obtain the best length accuracy and repeatability, before printing, advance the leading edge until the end of the belt or attach it to the TUR.

Know that reprinting a tile later increases the likelihood of length discrepancies compared to the other tiles. The total length repeatability depends on the substrate, changes in environmental conditions, and the contents of each job, especially when the substrate reacts differently to varying ink densities.

Substrate has bow deformation

Bow deformation occurs when the substrate does not lie flat, exhibiting an arched profile.

The following substrates may suffer from bow deformation during printing, as a result of which the print will appear curved:

- Self-adhesive vinyl substrates (some specific calendared vinyls only)
- Cellulose-based poster papers with no backing nor coating, including HP Photorealistic

This deformation may be particularly noticeable in the following applications:

- Printing images that will later be cut automatically or manually. When there is bow deformation, cutters that are aligned on the sides may lose alignment in the center.
- Poster printing, if the poster is framed or mounted on a straight surface.

The example below shows an original image, the substrate suffering from bow deformation, and the resulting print, also suffering from bow deformation.



You can compensate for this effect and restore the original shape of your image: select a correction value from -6 to $+6$ in your RIP or in the substrate library. To apply the correction in your RIP, please refer to your RIP documentation.

The chosen value should represent the vertical distance that the centre of the substrate has moved with respect to the left and right edges. If the deformation moves the center of the substrate in the direction of substrate advance, the correction value should be negative; if in the reverse direction, the correction value should be positive. In practice, the required correction value is normally negative.

 **TIP:** You can use the diagnostic image provided in <http://IPaddress/hp/device/webAccess/diagnostic/StraightnessOptimizationPlot.pdf> (where *IPaddress* is the IP address of your printer) to help you to determine the correct value to apply.

Rigid substrate registration troubleshooting

This topic explains the concepts involved in this subject.

Leading edge

This section provides the complete information.

Leading edge skew

Skew in the leading edge refers to the effect on the front edge of the sheet when the edge of the image is not parallel to it.

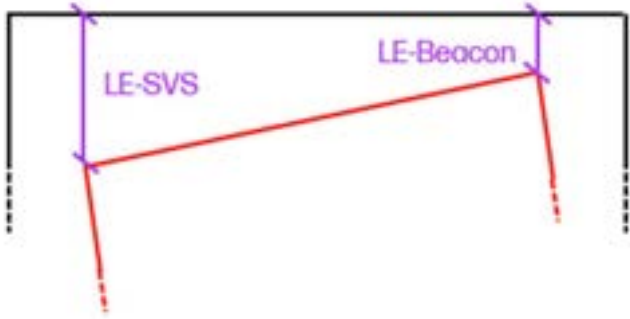

The black rectangle (external) represents the board and the red rectangle represents the plot (internal).

Check the following to avoid this issue:

- Loading table
 - Ensure the loading table is properly attached to the printer and is correctly levelled. Use a bubble level for verification.
- Material protrusions
 - Ensure the edge touching the alignment bar has no protrusions that could cause misalignment between the board and the bar.
- Loading recommendations
 - The media must be aligned to the alignment bar, the one with the ruler on it. The lateral bar, which can be lifted by rotating, is only a lateral reference.
 - Good practice is to ensure that both corners of the leading edge of the board are touching the alignment bar, and that the side edge is in contact with the lateral bar. For more information, see [Load a single sheet on page 43](#).
 - Lift the lateral bar immediately after pressing the **Feed** button to prevent the lateral edge from contacting the bar, which could cause board rotation.
 - When loading multiple boards, remember to lift the pin before pressing the **Feed** button.

Leading edge offset

Offset in the leading edge refers to a condition where the entire image shifts relative to the front edge of the substrate. This may cause the image to print partially on the belt or result in a visible white or material colored line along the front edge of the sheet, indicating that the image was printed too far into the board.

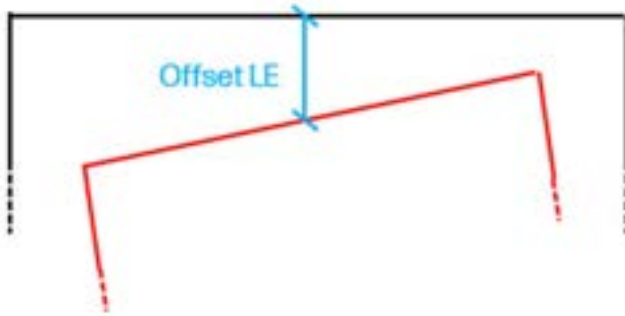

Check the following to avoid this issue:

- Check margins
 - Check that there are no margins applied to the image\.
- Loading table
 - Ensure the loading table is properly attached to the printer and is correctly levelled. Use a bubble level for verification.

Lateral edge

This section provides the complete information.

Lateral edge skew

Skew in the lateral edge refers to the effect on the side edges of the sheet when the edge of the image is not parallel to them.

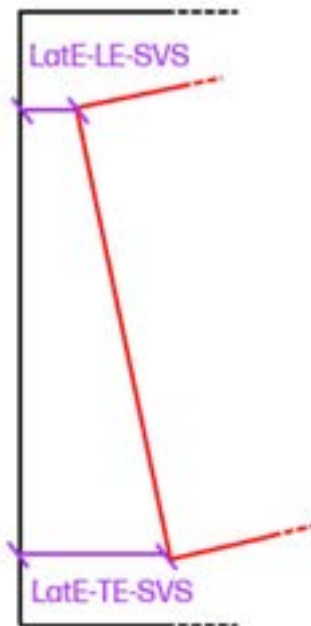

Check the following to avoid this issue:

- Material squareness
 - Check that the material is cut square. If it is not properly cut, leading edge offset may occur.
- Belt stabilization
 - After rewinding material during the unloading of flexible media, the belt may become destabilized. To correct this, move the belt forward 10,000 mm using the IPS to ensure proper stabilization.
- Loading recommendations
 - The media must be aligned to the alignment bar, the one with the ruler on it. The lateral bar, which can be lifted by rotating, is only a lateral reference.
 - Good practice is to ensure that both corners of the leading edge of the board are touching the alignment bar, and that the side edge is in contact with the lateral bar. For more information, see [Load a single sheet on page 43](#).
 - Lift the lateral bar immediately after pressing the **Feed** button to prevent the lateral edge from contacting the bar, which could cause board rotation.
 - When loading multiple boards, remember to lift the pin before pressing the **Feed** button.

Lateral edge offset

Offset in the lateral edge refers to a shift in the image position along the leading edge, specifically where printing begins. To check for this issue, align the image in the IPS to the edge closest to the Service Station (SVS) and observe the alignment along the leading edge.



Check the following to avoid this issue:

- Line sensor

- The line sensor may be dirty and require cleaning.
- Material
 - Check that the edge of the material is properly cut. If the edge is diagonal or uneven, the sensor may lose accuracy.
- Belt stabilization
 - After rewinding flexible media during unloading, the belt may become destabilized. Move the belt forward 10,000 mm through the IPS to restabilize it.
- Alignment in IPS
 - Verify that the image alignment is correctly configured in the IPS.
- Margins
 - Ensure that no unintended margins are applied to the image.

Trailing edge

This section provides the complete information.

Trailing edge skew

Skew in the trailing edge refers to the effect on the rear edge of the sheet when the edge of the image is not parallel to it.

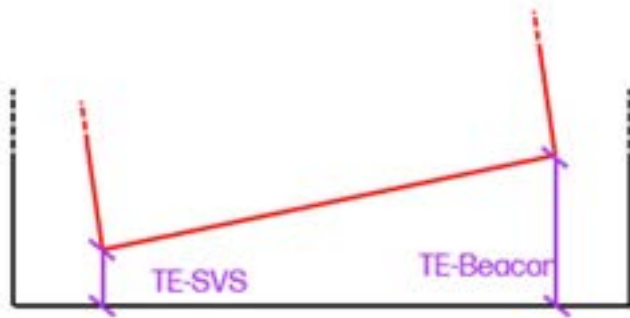

Check the following to avoid this issue:

- – Material squareness
 - Check that the material is cut square. If it is not properly cut, leading edge offset may occur.
 - Material protrusions
 - Ensure the edge touching the alignment bar has no protrusions that could cause misalignment between the board and the bar.
- Loading table
 - Ensure the loading table is properly attached to the printer and is correctly levelled. Use a bubble level for verification.
- Loading recommendations

- The media must be aligned to the alignment bar, the one with the ruler on it. The lateral bar, which can be lifted by rotating, is only a lateral reference.
- Good practice is to ensure that both corners of the leading edge of the board are touching the alignment bar, and that the side edge is in contact with the lateral bar. For more information, see [Load a single sheet on page 43](#).
- Lift the lateral bar immediately after pressing the **Feed** button to prevent the lateral edge from contacting the bar, which could cause board rotation.
- When loading multiple boards, remember to lift the pin before pressing the **Feed** button.

Trailing edge offset

Offset in the trailing edge refers to the effect where the image shifts entirely relative to the rear edge. This can result in printing the image on the belt or a white or material-colored line appearing on the front edge of the sheet because the image is printed too far into the board.

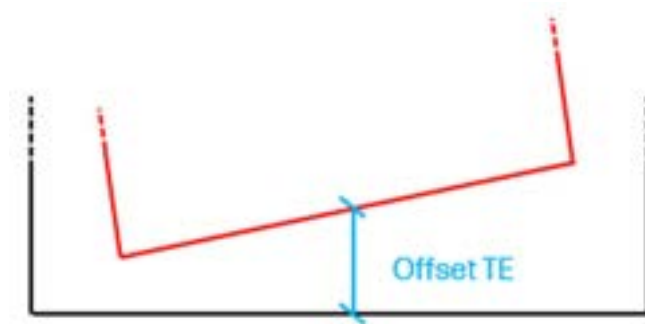

Check the following to avoid this issue:

- Board length
 - Check that the board length has been correctly entered during loading.
- Image margins
 - Check that there are no margins applied to the image.

11 Printing issues

The following sections provide details for this topic.

There are physical marks on the substrate

The following steps provide the complete procedure for this topic.

This only can occur when substrates sensitive to permanent deformation are used. These marks are usually seen in isolated areas and mainly caused by high curing temperature or substrate tensions.

Here are some ways to correct the problem:

1. Check that the substrate you are using is the same type as the one selected in the Internal Print Server.
2. Check that there are no defects at the substrate edges.
3. Check that you are using the generic substrate preset for the substrate category. The use of incorrect values could cause incorrect substrate behavior.
4. Flexible substrate only: Reload the substrate and try to minimize skew while loading. Check that you are loading the substrate using the correct procedure.
5. Try to reduce curing temperature and ink quantity, and raise the curing airflow to help reduce substrate deformation.

Belt marks on flexible media

In some media, especially self-adhesive vinyls, deformations may occur just after printing, replicating the belt pattern. These are liner deformations and will not appear in the final application. They will disappear after a few hours or days.

To minimize these deformations, the curing zone vacuum can be slightly reduced by 250 Pa (e.g., from 1000 to 750 Pa). However, this adjustment may reduce the margin for avoiding wrinkles.

Belt marks on rigid media

Belt marks are visible patterns that may appear on certain materials, replicating the texture of the conveyor belt.

Causes and solutions:

- **Single-sided printing:** Belt marks may result from permanent deformation on the unprinted side, caused by excessive curing temperature and vacuum pressure.
 - **Possible solution:** Reduce the curing temperature by 5 °C and/or decrease the vacuum level by approximately 250 Pa.
- **Double-sided printing:** Belt marks can occur when the already printed side comes into contact with the conveyor belt.

- **Possible solution:** This is a known limitation, but it can be mitigated by placing a soft, porous, vacuum-permeable material, such as felt, between the substrate and the belt. This acts as a protective separator to prevent the printed side from being marked.

Pinch marks (vertical marks) on rigid media

with some media, plastic solids, the pattern of the pinch wheels can be seen in the media, especially at the leading edge, disappearing along the plot. In these cases, it is recommended to:

- Clean the pinch wheels from aerosol and plasticizers, especially after printing with white ink over a long run.
- In some plastic solids, this issue may only appear in the first 100mm of the plot. In these cases, severity can be reduced by loading without the “width automeasure” and entering the width manually.

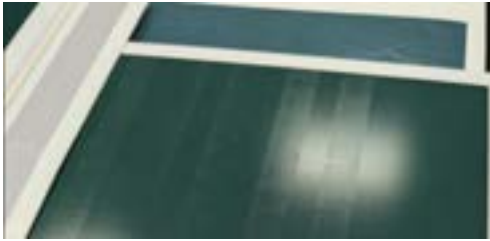

Rigid substrate too close to the carriage bottom

If a rigid substrate is too close to the bottom of the carriage, issues may arise even if the material was loaded flat and remains flat during printing. This can result in smears if the carriage touches the printed image, or crash sensor may cancel the job if contact occurs near the printheads.

Possible Causes and Solutions:

- **Localized defects in the material**
 - Ensure that the substrate edges are free from defects.
 - Inspect the printing area to confirm no material irregularities are present.
- **Material deformation during printing**
 - Ensure the substrate remains in full contact with the conveyor belt during printing.
 - Verify that initial material deformations do not exceed the specified tolerances.
 - Confirm that the substrate selected in the IPS matches the actual material being used.
 - Check that the output roller and Media Edge Pinch Wheels are installed, or if they are recommended for the specific substrate type.

There are wrinkles and ink smears on the substrate

If your prints suffer from any of the defects caused by wrinkles, here are some suggestions:

Wrinkles in the substrate indicate that the substrate settings that control the substrate shape are not optimized. This can cause various printing defects:

- Colored bands in area fills in the vicinity of the wrinkles.
- Ink smears if the printhead touches the substrate.
- Cockle.
- A substrate crash if the printhead's movement over the substrate is impeded.

There are various reasons why wrinkles and other consequent effects could appear while printing:

- Incorrect loading of the substrate/
- Drying and curing temperatures too high for the substrate.
- Differential expansion of the substrate due to variations in temperature.
- Non-uniform tension across the substrate when loading.
- The roll loaded on the input roll rewinder has been wound with different tensions at its two ends.

 **NOTE:** When printing with rolls that have not been precisely wound with the same tension along their width during manufacturing, you may notice that, while printing, one of the sides of the substrate between the input rewinder and the main roller loses all tension. This may cause wrinkles on the substrate-advance belt or telescoping on the take up reel.

If your prints suffer from any of the defects caused by wrinkles, here are some suggestions:

1. Check that the substrate you are using is the same type as the one you have selected in the Internal Print Server.
2. Check that you are using the generic substrate preset for the substrate category. The use of incorrect values may cause incorrect substrate behavior.
3. Check that there is no telescoping of the input roll.
4. Ensure the hold down plate is placed over the media in the printer input.
5. Reload the substrate and use the automatic de-skew process. Check that you are loading the substrate using the correct procedure.
6. Check that there are no defects at the edges of the substrate.
7. If you have experienced a substrate crash due to the lateral edge of the substrate when printing consecutive jobs, leave a larger gap between the first and second job. Sometimes, after curing, when the media is moved back to the pinch wheels, wrinkles may appear on the sides.
8. Try reducing the drying airflow and curing temperature.
9. Try reducing the curing temperature and ink quantity to help in reducing the substrate's thermal contraction.
10. If you cannot get rid of the wrinkles, try raising the carriage beam slightly, so that the printhead is not so close to the substrate.
11. If your substrate is deformed or wrinkled by the curing process, decrease the curing temperature before printing the next job, and advance the substrate, so that the next job will be printed on undamaged substrate.

12. Ensure that the vacuum belt is strong enough to keep the substrate flat on the belt during the loading process.

Meda advance issues

The following steps provide the complete procedure for this topic.

The substrate advances with a loud continuous sound of vibration

The following steps provide the complete procedure for this topic.

A loud continuous sound of vibration during the substrate advance can be caused in the following ways:

- The input roll rewinder is not applying tension.
- Wrong tension or vacuum settings result in an incorrect balance of forces on the main roller.

If you hear this sound, here are some suggestions:

1. Check that the substrate you are using is the same as the one you have selected in the Internal Print Server.
2. Check that you are using the generic substrate presets for the category. The use of incorrect values may result in incorrect substrate behavior.

 **NOTE:** Only substrates with high friction along the substrate-advance belt or substrates that easily wrinkle with temperature need high output tension values. Check that your output tension is recommended for your substrate.

3. Check that there is no telescoping of the input roll.
4. Reload the substrate and try to minimize skew while loading. Check that you using the correct loading procedure.
5. Increase the input tension in steps of +5 N/m from the recommended setting for each category until you eliminate the issue.

There is skew or telescoping on the output roll rewinder

When suffering from extreme skew that tends to increase (normally with highly temperature-sensitive substrates), try to use a thicker core that is not deformed by the rubber traction grooves on the roll rewinder when inflated. Then follow the guidelines below for reducing skew.

Extreme skew (approximately 10 mm peak to peak) and telescoping in the output roll rewinder while it winds can be caused in three main ways:

- The substrate has not been correctly loaded and aligned during the loading procedure.
- The roll loaded on the input roll rewinder is skewed, and this skew is transferred to the output roll rewinder.
- The roll loaded on the input roll rewinder has been wound with different tensions at its two ends.

Printing on rolls that are not wound accurately during manufacturing may lead to wrinkles and skew problems and, generally, this problem can be identified easily because you can see a loss of tension at one side of the substrate between the input roll and the main roller. In that case, see the relevant information provided in the section [There are wrinkles and ink smears on the substrate on page 167](#).

 **TIP:** Generally, the main contributor to skew is an imprecise substrate load, and the effects of that are worse with wide rolls. However, if you have some skew or telescoping but this does not affect your print quality, and does not generate wrinkles in the substrate (see [There are wrinkles and ink smears on the substrate on page 167](#)), there is no need to take any action.

 **IMPORTANT:** HP recommends using the automatic de-skew process in all roll loads.

There are ink marks on the substrate

This problem can occur if any component in contact with the substrate is dirty. Check the substrate-advance belt, pinchwheels, and curing module plates, and clean them if necessary.

12 Troubleshoot print-quality issues

Print-quality issues could include graininess, banding, color variation or misalignment, and smearing or bleeding of ink, among others.

General printing advice

Use the approach described here when you have any print-quality problem.

- Ensure that the substrate type that you select on the control panel, and in your RIP software, is the same as the substrate type that is loaded in the printer. Make sure that the substrate type has been calibrated (including substrate-advance calibration, printhead alignment, and color calibration).

 **CAUTION:** If you have the wrong substrate type selected, you could experience poor print quality and incorrect colors, and perhaps even damage to the printheads.

- Ensure that you are using the correct substrate preset for your substrate, with the correct ICC profile, or that you have followed the correct procedure to generate a new substrate preset (see [Add a substrate preset on page 81](#)).
- Ensure that you are using appropriate print-quality settings in your RIP software.
- Confirm that you are printing on the right side of the substrate.
- Ensure that your environmental conditions (temperature, humidity) are in the recommended range. See [Environmental specifications on page 223](#).
- Ensure that you shake your ink cartridges before installing them. See [Replace a 3 liter Eco-Carton ink cartridge on page 95](#).
- Ensure that your ink cartridges have not passed their expiration dates.
- Avoid touching the substrate before printing, as fingerprints can detract from the print quality.
- Avoid touching the substrate while printing is in progress.
- Printing jobs with a lot of ink in fast modes (commonly 6 passes or below) may result in not-completely-dry output and/or other print-quality problems. Consider using modes with higher passes when printing with a lot of ink, or increase the curing temperature. Note that increasing the curing temperature may deform your substrate.
- Evaluate the print quality only after the print has completely emerged from the printer. In some cases, defects seen during printing disappear once the image is fully cured. Ensure that the substrate is flat and has no wrinkles. See [Troubleshoot substrate issues on page 156](#).

If these basic checks do not solve your problem, there is more specific advice in the table below.

NOTE: This table takes into account issues that were not solved by doing the basic checks.

Follow the troubleshooting order given by the numbers

Recommendations before printing

- Close the printer's lid or disconnect from wireless mode (optional)
- Perform a color calibration (ICC)

Basic checks

- ✓ Print head health
- ✓ Print head alignment
- ✓ Toner/dye advance
- ✓ Correct substrate used

Increasing settings affects the print quality issue positively

Decreasing settings affects the print quality issue positively

Changing the setting exponentially related provides another print quality defect

- Substrate used
- Substrate condition
- Ink/dye
- Print head
- Ambient condition
- Method employed

Check the head to troubleshoot

| Issues | Values | Horizontal banding | | Vertical banding | Scan | Tonal quality | Band | Print-out speed | Tearing | | White ink issues | | Durability | |
|---------------------------|-----------------------------------------------------------------------------------------------------------------------------------------------------------------------------------------|----------------------------------------------------------|---------------|------------------|-----------------------------------|--------------------------------------|--------------------------------------------------------|------------------------|------------------------------------------------------------------------------------------|--------------|------------------------------------------------|---------------------|-----------------------|------------------------------------------------------------------------------------------------------------------|
| | | Dark to light zone banding | Light banding | | | | | | From curing | From varnish | DC halo | IP vertical banding | WPCM | Wet |
| Issues | NA For S&C don't forget the figure | 1 ↑ | | 1 ↑ | 2 ↑ | | | 1 ↑ | 1 ↑ | 1 ↑ | | 2 ↑ | | |
| Ink density | 12% (if you decrease ink density, decrease curing temperature) | 1 ↓ | | 1 ↓ | 1 ↓ | | | 4 ↓ | 4 ↓ | 3 ↓ | | 1 White % ↓ | | |
| Curing time | 4% | 1 Ⓞ | | | 1 Ⓞ | | | 1 ↑ | | | | | | |
| IP offset in color region | 1 step | | | | | 2 ↑ | | 2 ↑ | | | | | | |
| IP offset in color region | 1 step | | | | | 2 ↑ | | 2 ↑ | | | | | | |
| Current | 0.3 amp | 1 Ⓞ | | | | | | | | | 2 ↓ | | | 1 ↑ |
| Curing temperature | 2°C | 2 ↑ | | 3 ↑ | | | | 1 ↑ | 2 ↓ | 3 ↓ | | | 2 ↓ | 1 ↑ |
| Wipe head delay | 30ms (if you add more sweep delay, decrease curing temperature) | | | | | | | 2 ↓ | 1 ↓ | 4 ↓ | | 1 ↓ | | 2 ↓ |
| Resistor | 3 ohms (for 100 range) (downside) for 10 range | | | 3 ↓ | | | | 3 ↓ | 1 ↓ | 2 ↓ | | | | |
| Print zone temperature | 2°C | | | 1 ↑ | | | | 2 ↑ | | | | | | |
| Print zone width | 30mm | | | 3 ↓ | | | | | | | | | | |
| Print head | <ul style="list-style-type: none"> - 4 for general substrates - 8 or 10 for thin substrates (A whites) - 5 for bottle facilities that tick to the roll | | | | | | | | | | | | | |
| Print head | <ul style="list-style-type: none"> - 4 for general substrates - 8 or 12 for general substrates | | | | | | | | 1 ↑ | | | | | |
| Print zone | | For white, increase current (same density, higher power) | | | 4. Check substrate qualifications | 4. Set bar -Relayout -Change pinhead | For white, increase power (same density, higher power) | 3. Curing module issue | Print control: 1. Set extra top margin, 2. Put out of curing 3. Attach the full | 1. Use T&B | 1. Use transparent (SAI or PET) generic primer | 1. Smart check | Alternative substrate | 1. Lamination DC=0 Cleaner: 1. Use only water and low concentration soap 2. Wash 2x before cleaning |

Improve print quality

You can follow a more hands-on print-quality troubleshooting procedure by printing, interpreting, and performing corrective actions.

Recommended process for improving print quality

See the flowchart for full details of the recommended process.

1. Print the printhead status plot: see [Printhead status plot on page 175](#).
2. If nozzle health seems poor (defects in area fills, many nozzles not working), in the IPS, go to **Printheads**, tap the **3 dots** and select **"Hard cleaning"**, then **Continue**, and select the printhead(s) to be cleaned. You can do this twice, but no more than twice.

As a last resort, you can clean a printhead manually with a soft, fiber-free cloth dampened with de-ionized water. Clean gently, with minimal pressure.

CAUTION: Do not use the same cloth to wipe optimizer and non-optimizer printheads. This may lead to unrecoverable nozzle defects.

3. Reprint the printhead status plot. If nozzle health still seems poor, replace the faulty printhead(s).
4. If nozzle health now seems good, but your own prints still have quality defects, check the printhead alignment: see [Alignment status plot on page 176](#).
5. Check the weight of your printheads. If a color printhead is below 54 g, or a white printhead is below 57 g, replace the printhead.

6. If nozzle health and printhead alignment both seem good, and the printheads are not underweight, but your own prints still have quality defects, the problem is probably not caused by the printheads. Check the substrate advance.

The flowchart below shows the process in more detail.

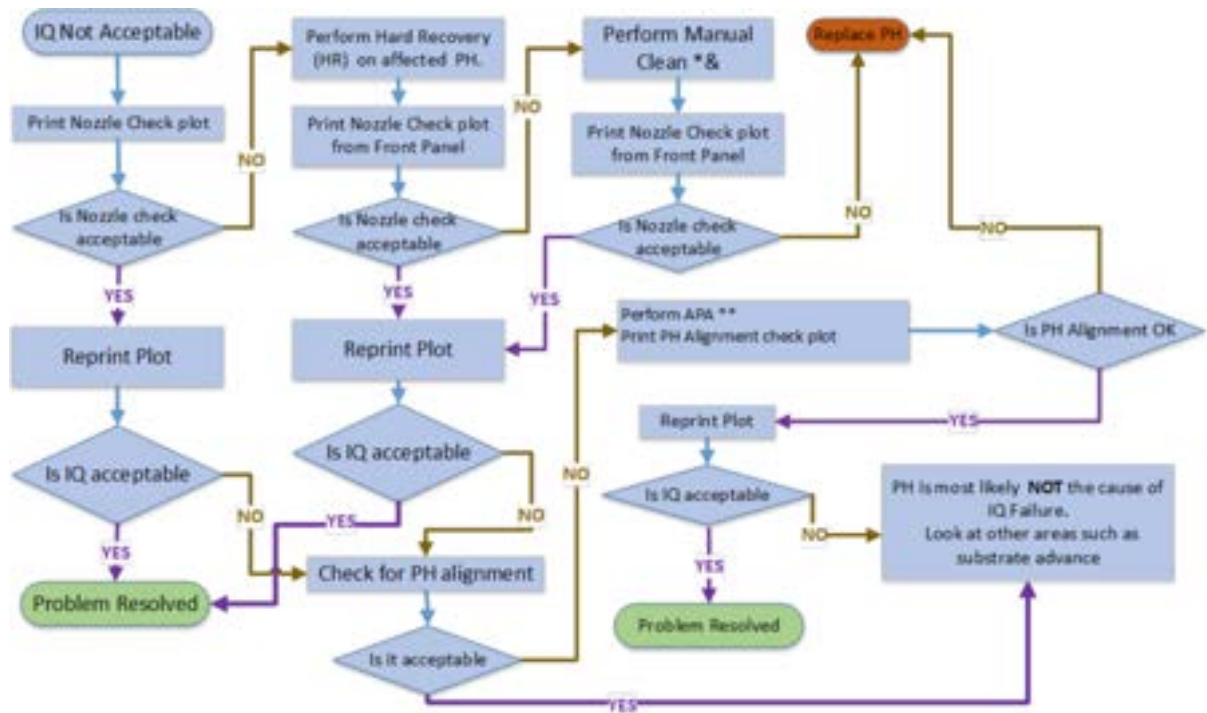

As a last resort, you can clean a printhead manually with a soft, fiber-free cloth dampened with de-ionized water. Clean gently, with minimal pressure.

CAUTION: Do not use the same cloth to wipe optimizer and non-optimizer printheads. This may lead to unrecoverable nozzle defects.

** Manual alignment only if the substrate does not support automatic printhead alignment (APA).

For white printheads, the recovery will be performed on one or both depending on the type of print:

- UF prints: HR on W2
- OF prints: HR on W1
- Spot mode: Both W1 and W2

Acceptable nozzle check

- This is not easily quantifiable. A printhead can still give good print quality with many nozzles out.
- Check the area fills for banding lines.

Printhead check and clean

This process cleans all printheads.

This process can be manually triggered by clicking on **Printheads**, then **Check and clean**.

The check and clean process can be scheduled to run automatically before the printer's typical operating hours. For example, you can schedule it for 5:00 AM if printing usually begins at 6:00 AM. To enable this feature:

1. Go to **Printheads**, then click ... **(more options)**, and select **Schedule**.
2. Turn on the **Scheduler**.
3. Choose the desired time and days for the process to run.
4. Click **Apply** to confirm the settings.

Schedule

Schedule check and clean On
Check and clean will be performed only if printer is idle

Time (24 h)

Days

Monday Tuesday Wednesday Thursday
 Friday Saturday Sunday

Printhead hard cleaning

Unlike the check and clean process, which is performed on all printheads, hard cleaning is intended for individual printheads that require deeper cleaning.

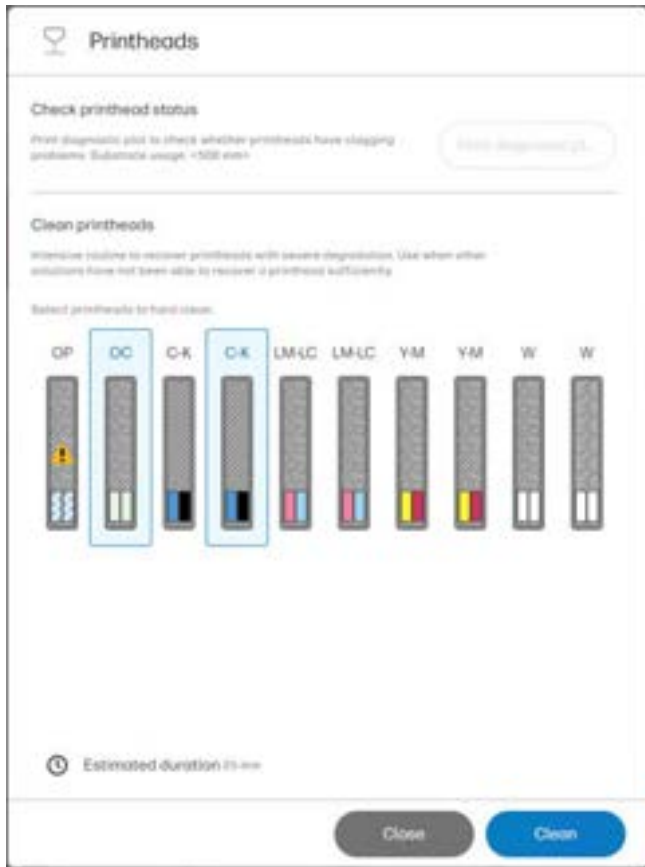

To determine which printheads need hard cleaning, first print the printhead status plot. For instructions, see [Printhead status plot on page 175](#).

1. Select **Printheads**, then tap ... **(more options)**, and select **Hard Cleaning**.
2. Select the printheads that showed defects in the status plot.
3. Click **Clean** to begin the process.



Printhead status plot

The printhead status plot consists of patterns that are designed to highlight printhead reliability problems. It helps to determine whether any printhead is experiencing clogging or other problems.

To print this plot, go to the Internal Print Server and select  →  → **Hard cleaning** → **Print diagnostic plot**. Vinyl, preferably gloss at least 24 inches wide, is recommended for maximum visibility. Other substrate types may not show enough detail to see the optimizer dashes clearly.

The plot consists of area fills (filled rectangles in each color), followed by small dashes, one for each nozzle on each printhead.



For each individual colored pattern, check that most of the dashes are present. If the first area fills have banding, compare with the respective color in dashes below.

IMPORTANT: Nozzle health is not normally perfect, and does not need to be perfect: the printer is designed to perform well with some nozzles not functioning. However, if many nozzles are not functioning, you may start to see visible defects in the area fills and in your prints.

1. Clean any faulty printheads. See [Check and clean the printheads on page 132](#). Then reprint the printhead status plot to see whether the problem has been solved.
2. If the problem persists, clean the printheads again, and reprint the printhead status plot to see whether the problem has been solved.
3. If the problem continues to persist, replace any persistently faulty printheads. See [Replace a printhead on page 98](#).

Alignment status plot

Follow the procedure described to print the printhead alignment status plot.

1. Use the same substrate type that you were using when you detected a problem. Or consider using vinyl gloss substrate for better visibility of the optimizer in particular.
2. Go to the control panel and tap **Printheads**, then **...**, then **Align**, then **Manual**, then **Print**.



Check that all color to color patterns look like the case shown in the legend on the left. If any adjustments are necessary, make them in the control panel to calibrate them. See [Align the printheads on page 126](#).

Advanced PH nozzles health check

Over time, the optimizer printhead may accumulate air, which gradually lowers its weight, from approximately 65 g to 50 g. Depending on the amount and location of the trapped air, print quality may be affected, resulting in visible defects such as bleed.

To detect the presence of air near the nozzle area, the Advanced PH nozzles health check can be used. This diagnostic plot prints all nozzles at maximum saturation. If sufficient air is present near the nozzles, the result may show unprinted areas (referred to as starvation) or the plot may be canceled due to thermal shutdown during printing. In such cases, the printhead must be replaced.

To print the plot, select **Diagnostics** → **Printheads** → **27004 Advanced PH nozzles health check**.

This is a good plot. The image is complete from end to end:



This is a defective plot showing a condition called starvation. It appears as a faded, non-uniform area.



What to do if problems persist

If you still experience print-quality problems after applying the advice in this chapter, here are some additional tips to consider.

- Try selecting a higher print-quality option in your RIP software, by increasing the number of passes.
- Check that your printer firmware is up to date. See [Update the printer's firmware and software \(Internal Print Server\) on page 23](#).
- Check that you have the correct settings in your software program.
- Call your service representative. See [When you need help on page 2](#).

Most-common print-quality problems

The most common print-quality issues include graininess, horizontal or vertical banding, color variation or misalignment, hazy black areas, smearing or bleeding of ink, uneven area fills, tiling issues, and others.

Graininess

Grain is a print quality defect characterized by a rough, uneven texture or a speckled appearance. Typically, visible in areas of solid color or continuous tone images. It occurs when the printed dots are not evenly distributed, leading to a coarse or mottled effect instead of a smooth finish.



- Check the nozzle health by printing the Printheads Status Plot and clean the printheads if needed. Including the transparent fluids, optimizer and overcoat.
- Check that the media thickness setting in the IPS matches the actual media thickness.
- The printheads may be misaligned. This is likely if you have not aligned the printheads for a long time, or if there has been a substrate jam. Print the Printhead Alignment Status plot and align the printheads if necessary.
- In certain conditions such as high humidity, low temperatures, or when a defective coating is used, some substrates may develop a grain effect caused by wetting issues. Dots tend to cluster into larger dots with empty spaces between them. Use a magnifying glass to examine the print in greater detail. To improve coalescence, try the following:
 - Increase the amount of optimizer level
 - Increase the drying airflow
 - Adjust ink density level

Horizontal banding

Horizontal banding is a print quality defect characterized by visible horizontal streaks, lines or bands in an image or solid color area.

Dark link banding

These are thin, dark lines that span the entire image at regular intervals. They are most noticeable in solid fill areas.

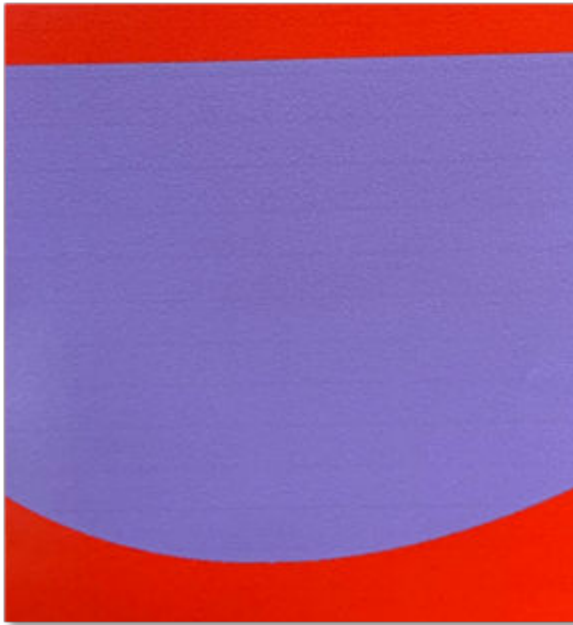

To improve dark-line banding

- If bands affect most of the colors, the printheads could be misaligned. This is likely if you have not aligned the printheads for a long time, or if there has been a substrate jam. Print the Printhead Alignment Status plot and align the printheads if necessary.
- The problem may be related to the substrate advance. Check that size and weight of the substrate is within specs and it's loaded correctly.
- Another cause could be a fiber attached to one of the printheads. Turn off the printer, then remove the printheads one at a time and remove any fibers that you see attached to them.

Thin white-line banding

These are thin lighter lines across the entire image at regular intervals, more easily seen in solid area fills.



To improve white line:

- Check the nozzle health by printing the Printheads Status Plot and clean the printheads if needed.
- If banding affects most colours, the printheads may be misaligned. This is likely if the printheads have not been aligned for a long time or following a substrate jam. Print the Printhead Alignment Status plot and align the printheads if necessary.
- Increase the number of passes by using a quality print mode.

Bands of light and dark zones

These are periodic horizontal bands. This pattern is mostly seen in solid dark color. This problem is caused by the ink on media drying interactions and is highly dependent on media family.



To improve banding:

- Check the nozzle health by printing the Printheads Status Plot and clean the printheads if needed.
- If banding affects most colours, the printheads may be misaligned. This is likely if the printheads have not been aligned for a long time or following a substrate jam. Print the Printhead Alignment Status plot and align the printheads if necessary.
- Increase the number of passes by using a quality print mode.
- If you are printing on aluminum composite panel, you can try the High Quality With White Underlayer print mode.

Gloss banding

In dark, high-density areas, horizontal bands of gloss or matte finish may appear. They are only visible at certain light angles. This phenomenon can occur when the curing system settings are not appropriate for the substrate, when issues exist with the overcoat printhead, or when an excessive amount of overcoat is applied.



- Check the nozzle health by printing the Printheads Status Plot and clean the printheads if needed. Specially the Overcoat printhead.
- Try to minimize or disable de Overcoat on the media settings.
- Increase the number of passes by using a quality print mode.

Aeroworms

Aeroworms are narrow, woven bands that resemble worms. They do not extend continuously across the substrate and appear randomly. When the ink is fired, airflow turbulence beneath the carriage can disrupt drop placement, producing this effect.



Try this to improve the aeroworms:

- Check that the media thickness setting in the IPS matches the actual media thickness.

- Increase the number of passes by using a quality print mode.
- Reduce the ink density.

Vertical banding

Vertical banding consists of thick vertical bands that appear in the areas between the drying diffusors. This defect is highly dependent on ambient conditions; higher temperature and humidity make it more visible.



Try this to improve drying bands:

- Decrease the drying airflow. Graininess level may increase.
- Increase optimizer. Edge roughness caused by bleed may increase.

Vertical Gloss Banding

Vertical gloss banding consists of thin vertical gloss bands (or honeycomb pattern) that appear in areas with high saturation colors that reproduces impinging hole curing platen.

This defect is highly dependent on ambient conditions; higher temperatures and humidity make it more visible. The most sensitive medias are Plastic Solid, ACP, Self Adhesive Vinyl and PVC Foam.

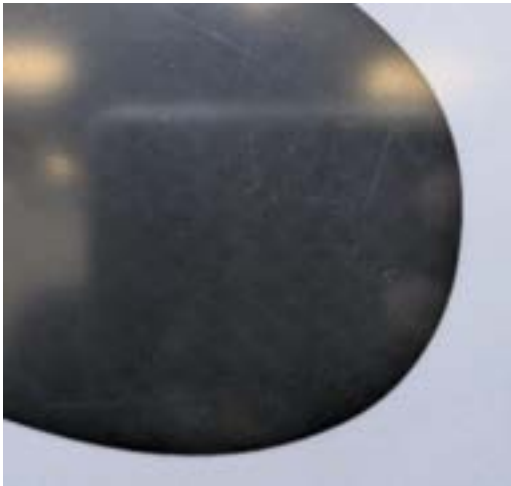



Try to improve vertical gloss banding by:

- Doing the curing cleaning maintenances as per the maintenance schedule.
- Reduce the amount of Optimizer. This may cause ink-bleeding that can be fixed by increasing the drying airflow or decreasing the ink density.
- Increase the Curing height. This may cause risk of reducing the curing capacity (worse durability) that can be compensated increasing the Curing Temperature or adding Inter-swath delays offsets.

Local color variation

These print-quality issues are likely to be caused by the condition of ink in the printhead nozzles.

Local color variation is characterized by an increased concentration of colorant in individual drops after short idle periods. This defect occurs when an image of a particular color is surrounded by other areas using similar colors, except for a specific zone. In that zone, the printheads are not refreshed properly, which results in inconsistent ink deposition.



To improve local color variation

- If you notice this defect near one side of the print, rotate the image by 90 or 180 degrees before printing. This may solve the problem in some cases because all the nozzles are refreshed when they enter the service station between passes.
- Use your RIP to add lateral color bars to the sides of the print. The color bars are designed to exercise all the printhead nozzles and help prevent the issue.



- If your RIP does not offer this option, add lateral color bars to the image before printing. You can use either the standard colors or a specific color where you have noticed the problem. The recommended width for each color bar is 3 mm.

Text quality

If text, lines, or light solid areas appear rough or blurred, follow these recommendations:

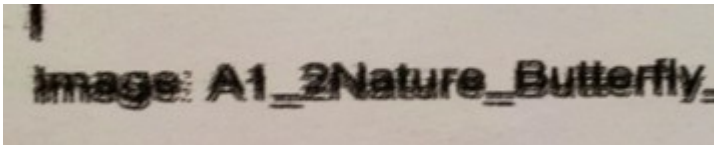
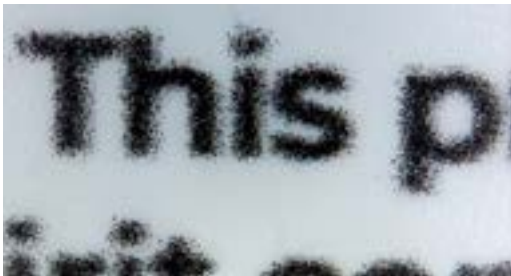

- Check that the media thickness setting in the IPS matches the actual media thickness.
 - Print the printhead status plot. See [Printhead status plot on page 175](#).
 - If necessary, clean the printheads. See [Check and clean the printheads on page 132](#).
 - Sometimes a single cleaning action may not be enough. Reprint the status plot and consider cleaning again.
- The printheads may be misaligned. This is likely if you have not aligned the printheads for a long time, or if there has been a substrate jam. Print the printhead alignment status plot (see [Alignment status plot on page 176](#)), and align the printheads if necessary (see [Align the printheads on page 126](#)).
- If the problem persists, you can modify the optimizer level in the advanced substrate settings.

Print is deformed into a curved shape

This may occur as a result of substrate bow deformation.

See [Substrate has bow deformation on page 159](#).

Misaligned colors

If the colors are misaligned in any direction, the printheads may be misaligned.



The printheads may be misaligned if you have not aligned the printheads for a long time, or if there has been a substrate jam. Align the printheads if necessary (see [Align the printheads on page 126](#)). You can check whether it is necessary by printing the printhead alignment status plot (see [Alignment status plot on page 176](#)).

Black areas look hazy

If black areas look hazy or not sufficiently black, try these suggestions.

- Increase the number of passes.
- Laminate the print.
- Substrate presets are designed to achieve consistent and reliable print quality on a broad range of substrates. However, you may want to consider investing in the color management process, using external tools and/or experts, to get specific results.

Ink smears

Ink smears may be seen on the print for the following reasons:

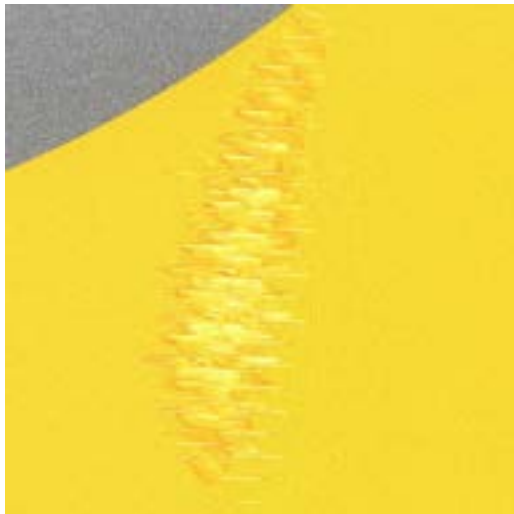

- The substrate is skewed. Do not ignore the warning message that appears during the loading procedure if there is significant skew.
- The substrate is not flat in the print zone. Try the following possible solutions:
 - Increase the vacuum level in steps of 5 mm H₂O.

- Reduce the curing temperature. You will probably need to increase the number of passes in order to achieve adequate curing.
- Check whether there are fibers on the printheads.

If the problem appears only at the sides of the print, because the edges are uneven or the substrate is curled upward at the sides, consider using the edge holders.

If the problem appears only at the beginning of the print, try the following suggestions:

- Increase the vacuum level in steps of 5 mmH₂O. Do not exceed the following limits: 20 mm H₂O for banners, 45 mm H₂O for vinyl, and 60 mm H₂O for other substrates. If the vacuum level is too high, you may see an increase in graininess due to too much friction between the rear surface of the substrate and the platen while advancing the substrate during printing; you may also see vertical bands matching the contours of the print platen.
- Decrease the number of passes.
- Make sure that the substrate is stored in the same room in which the printer is located.

 **NOTE:** Several substrates are sensitive to ambient conditions (temperature and humidity): if the ambient conditions are outside the recommended range, this may affect loading and printing.

Physical deformation marks

You may occasionally see physical deformation of the substrate.

This issue is not a mispositioning of the dots, but a physical deformation of the substrate that usually occurs after the dots have been printed. There are various kinds of deformation that may occur:

- Belt marks on the underside of the substrate, due to excessive heat.
- Deformation of flexible substrate, due to wrinkles induced by curing.

Both kinds of deformations can be the result of an excessive curing temperature. See [There are physical marks on the substrate on page 166](#).

Spray/static electricity

This topic provides a full set of reference information for this subject.

Some substrates have high electrostatic charges because of their liners, and they attract aerosol and dirt while printing. In this case, it helps to clean the substrate with a general-purpose industrial cleaner (such as Simple Green) before printing.



Bleeding

A small color migration may be observed at the border between different colors. It can also happen at the border between a color and blank substrate (no ink), reducing the sharpness of the shape. On some substrates, a halo can be observed at the border between colors.



Try the following suggestions:

- Check the nozzle health of all printheads, including those for transparent inks.
 - Print the printhead status plot. See [Printhead status plot on page 175](#).
 - If necessary, clean the printheads. See [Check and clean the printheads on page 132](#).
 - Sometimes a single cleaning action may not be enough. Reprint the status plot and consider cleaning again.
- The printheads may be misaligned. This is likely if you have not aligned the printheads for a long time, or if there has been a substrate jam. Print the printhead alignment status plot (see [Alignment status plot on page 176](#)), and align the printheads if necessary (see [Align the printheads on page 126](#)).
- If the problem persists, you can decrease the ink density, modify the optimizer level, or increase the drying temperature in the advanced substrate settings.

Uneven appearance in area fill

Subtle color differences may be seen in high-density area fills on some substrates if they are stored partially covered after printing. In the period immediately after printing, such substrates should be stored either totally covered or totally uncovered. It may be advisable to avoid prolonged face-to-face contact between two prints. This problem tends to disappear if the substrate is left uncovered for some time.

Alternatively, especially with vinyls and banners, some individual rolls may have a defective coating; for instance, the coating may have aged. This can cause uneven area fills in light areas. In this case, try using a new roll.

Ink is oily or smudges when touched

There are various different circumstances in which these symptoms can be seen.

- When the symptoms can be seen only at the start of the first print after the printer has been idle for some time (especially when the start of the print uses a lot of ink)

This may be just a temporary problem: try reprinting, and perhaps slightly reduce the ink limits. It may be worth adjusting the print queue so that the first job is not difficult to cure (uses a lot of ink).

- When the symptoms can be seen only in certain parts of the print that use a lot of ink
Increase the curing temperature, decrease the overall ink quantity, increase the number of passes, and/or modify the inter-pass delay offset (in the RIP or control panel) to allow better drying on consecutive passes.
- When the symptoms appear after reducing the number of passes
Increase the curing temperature, decrease the overall ink quantity, and/or modify the inter-pass delay offset (in the RIP or control panel) to allow better drying on consecutive passes.
- When the oily finish appears minutes or hours after printing
Store the print face-up and uncovered; the effect normally disappears after a while.
- When the ink transfers from the printed areas to the back side of the substrate after it is rolled up
Increase the number of passes, decrease the ink density, and/or increase the curing temperature. Also, you should not leave the roll on the floor or apply pressure to it.

 **NOTE:** If you decrease the overall ink quantity, you may notice less color saturation.

 **TIP:** To clean the prints, use only water and low-concentration mild soap solution. Do not use alcohol solvent-based cleaners. Wait 24 hours before cleaning.

You could try using a different substrate, which may have a higher resistance to this effect.

Dimensions of the print are wrong

As the substrate is heated during the curing process, some substrates will shrink (and some may expand) after the image has been printed. This may be inconvenient if the print has to be framed or if several prints are to be tiled one next to the other.

Tiling issues

The most common problems when printing tiles are described here.

- Color variation tile-to-tile

In some cases, contiguous tiles with the same background solid color may show differences in color between the right side of the first tile and the left side of the second tile. This is a common issue of inkjet printers (both thermal inkjet and piezo inkjet), where there are slight color variations as the swath advances.

To improve color consistency side-to-side and tile-to-tile, follow these recommendations:

- Ensure that your environmental conditions are suitable for best print quality. See [Environmental specifications on page 223](#).
- Print on a substrate already attached to the take-up reel.
- Use a print mode with a high number of passes: 8 passes are recommended for tiling mode.
- Use a print mode with a low ink density: the lower the better.
- Avoid printing with a cold printer: print 50 cm no more than 15 minutes before the tiling job. A nozzle health check is enough to warm up the printer.

Since the biggest color differences are between the left edge and the right edge, the effect may sometimes be seen when putting two tiles together. This issue can easily be overcome by inverting alternate tiles, which has the effect of placing the right side of the first tile next to the right side of the second tile and the left side of the second tile next to the left side of the third, so all contiguous areas have been printed in the same point of the swath and, hence, have the same color. This is a feature that all RIPs have available.

- Dimensional variations from tile to tile

Some substrates may not have uniform dimensional stability when printing very long tiles. The result is that the length of the tile may be different between the left and the right side (for instance, a 9-meter-long tile may be about 1 cm longer on the right than on the left side). While this is not noticeable with individual plots, it affects the alignment between panels in tiling applications. Substrate types that show this behavior tend to show it constantly along the roll. So, when present, this issue can easily be overcome by inverting alternate tiles as described above.

- Length consistency

When using the take-up reel, you can get better length consistency with increased take-up reel working force, although some substrates are sensitive to output tension, and print quality may be affected. You can change the take-up reel working force in the substrate preset.

- Self-adhesive vinyl usually requires lower output tension, and must have the take-up reel tension mode set to **Only apply tension after advancing**.
- Paper may require higher output tension, and must have the take-up reel tension mode set to **Do not apply tension**.

Other settings that can affect length consistency:

- Temperature: The higher the temperature, the more the substrate tends to deform. If you observe substrate deformation after printing, lowering the temperature can help to reduce the deformation.
 - Vacuum: High levels of vacuum can help to control the substrate in the print zone, but when the level is too high it can also affect the substrate advance. Therefore reducing the vacuum can help to improve length consistency. Take into account that, when the take-up reel is used, less vacuum is needed.
 - Input tension: To improve length consistency and skew performance, increase the input tension in steps of 5 N/m up to 25 N/m. Do not increase over 25 N/m because other print-quality issues may appear.
 - Substrate-advance sensor on/off: Some substrates may be challenging for the sensor to navigate, resulting in substrate-advance issues affecting the overall length. Turning off the substrate-advance sensor can help in these cases.
- In bidirectional printing, minor differences in tone may be noticed on close inspection

This happens because the drying times are not the same across the scan axis. Adding a small inter-pass delay offset of about 0.5-1 second may give better results.

White-to-color misalignment

Any slight misalignment between the color and white layers can cause unwanted white edges.



To improve print registration:

- The white printheads may be misaligned. This is likely if you have not aligned the printheads for a long time, or if there has been a substrate jam. Print the printhead alignment status plot (see [Alignment status plot on page 176](#)), and align the printheads if necessary (see [Align the printheads on page 126](#)).
- Check that the media thickness setting in the IPS matches the actual media thickness.
- If the problem is caused by substrate deformation, try reducing the curing temperature for the most heat-sensitive substrates.
- If the problem persists, you can adjust the white layer using the white ink option settings in the IPS.

The **Choke White Ink** option shrinks the white layer to prevent it from being visible.



The number of pixels used to shrink the white layer depends on the substrate, print mode, and white layer density. It is recommended to start with a value of 5 pixels and adjust as needed based on the printed result.

The comparison below shows the difference before and after applying a 5-pixel shrink. Note that the removed area is proportional to the image resolution. For example, 2 pixels at 300 dpi are equivalent to 4 pixels at 600 dpi.

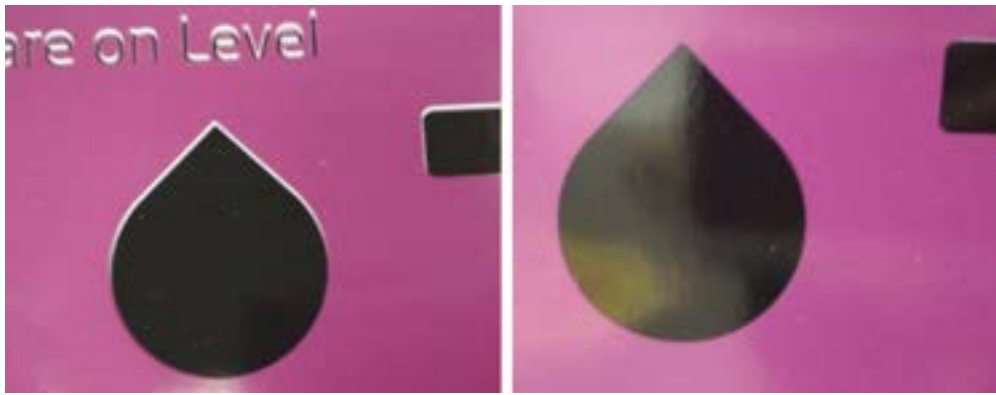

- If the shrink is added on the RIP, it will be applied on top of the value in the IPS.
- High opacity white print modes might require greater shrinking than fast white print modes.
- You can manually shift the white layer in any direction to improve the alignment to the color layer.
 - Horizontal shift: Use a negative value to move the layer to the left (service side), or a positive value to move it to the right (IDS side).
 - Vertical shift: Use a negative value to move the layer downward (media input side), or a positive value to move it upward (media output side).

| White layer offset | | |
|--------------------|----------------------------------------------------------------------------------------------------------------------------------------------------------|--------------------------------------------------------------------------------------------------|
| | <p>Pixels to move horizontally Negative value to move the layer to the left and positive value to move the layer to the right.</p> | <input type="button" value="-"/> <input type="text" value="0"/> <input type="button" value="+"/> |
| | <p>Pixels to move vertically Negative value to move the layer down and positive value to move the layer up.</p> | <input type="button" value="-"/> <input type="text" value="0"/> <input type="button" value="+"/> |

NOTE: Shrinking the white layer too much may cause other defects at the edges of the print.

Dual-side marks

You may see marks on some substrates when printing on the other side.



To improve belt marks:

1. Disable alignment correction movements in the loading menu.
2. Protect side A using a frame with holes or a permeable cloth to allow the vacuum to pass through.

13 Troubleshoot ink-system issues

Ink system issues include inability to insert an ink cartridge, installing an unshaken cartridge, sudden change of opacity, reseating a printhead, and system errors relating to recirculation timeouts, printhead and dummy blockages, and wrong calibration of PIP.

Cannot insert an ink cartridge

The following steps provide the complete procedure for this topic.

1. Check that you have the correct type of cartridge (model number).
2. Check that the colored label on the cartridge is the same color as the label on the slot.
3. Check that the cartridge is correctly oriented, the arrow on its front should face upwards.

Installation of an unshaken cartridge

Installing a white-ink cartridge not properly shaken may impact print quality, damage the white printhead, and degrade the performance of the white-ink delivery system.

You may face the following issues if an unshaken white cartridge is installed.

Sudden change of opacity

If you encounter this situation, perform the actions described here.

1. Remove the white-ink cartridge, shake it, and reinstall it.
2. Perform hard printhead cleaning (see [Improve print quality on page 172](#)) six times to remove the ink from the printhead and ink delivery system.
3. If the problem persists, contact your service representative.

Reseat printhead

If you need to reseat the printhead, perform the actions described here.

1. If there is a white printhead, remove the white-ink cartridge, shake it, and reinstall it.
2. Reinstall the printheads.
3. If the problem persists, clean with distilled water.
4. If the problem persists, replace the printheads.
5. If the problem persists, contact your service representative.

Recirculation timeouts: system errors 0022-0010-0190, 0022-0010-0197, 0022-0010-0198, 0022-0010-0199

If you encounter one of these system errors, perform the actions described here.

1. Remove the white-ink cartridge, shake it, and reinstall it.
2. If the problem persists, contact your service representative.

Printhead blockage: system errors 0022-0010-0192, 0022-0010-0193, 0022-0010-0195, 0022-0010-0196, 0027-0002-0045

If you encounter one of these system errors, perform the actions described here.

1. Remove the white-ink cartridge, shake it, and reinstall it.
2. Open the latch, check that the primer rubbers are in place (structure and latch), then close the latch.

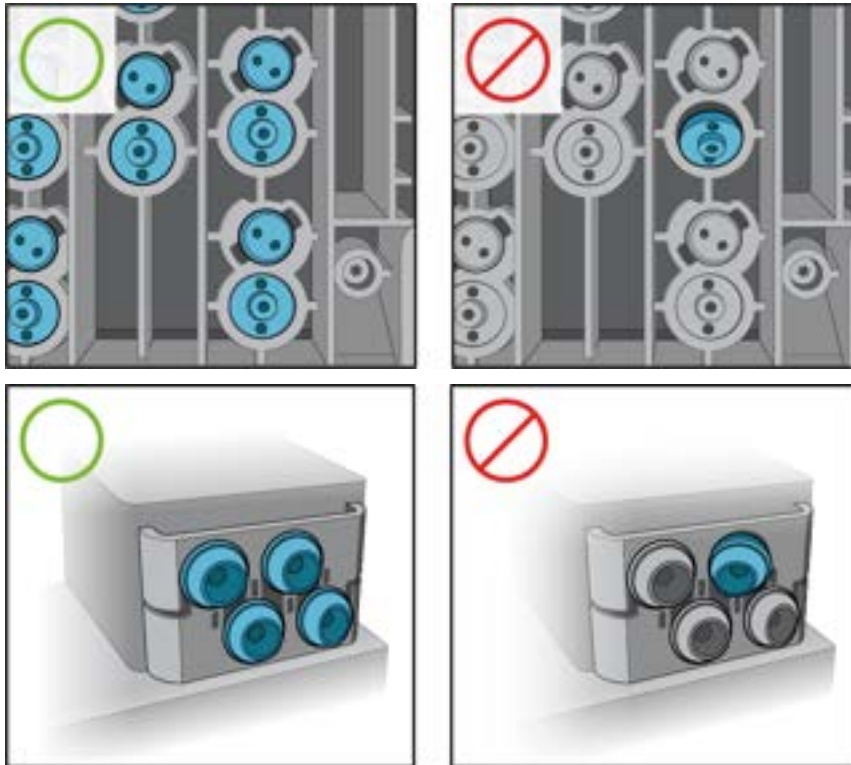

3. If the problem persists, replace the printheads.
4. If the problem persists, contact your service representative.

Dummy blockage: system error 0027-0002-0045

If you encounter this system error, perform the actions described here.

1. Remove the white-ink cartridge, shake it, and reinstall it.
2. Shake the dummy printheads and reinstall them.
3. If the problem persists, replace the dummy printheads.
4. If the problem persists, contact your service representative.

PIP wrong calibration: system error 0022-0010-0046

If you encounter this system error, perform the actions described here.

1. Remove the white-ink cartridge, shake it, and reinstall it.
2. If the problem persists, contact your service representative.

Control panel recommends reseating or replacing a printhead

If you encounter this situation, perform the actions described here.

1. Remove the printhead and check that it is free from physical damage and from ink stains on the electrical connections.
2. If necessary, clean the electrical connections between the printhead and the carriage. See [Clean the electrical connections on a printhead on page 132](#).
3. Reinsert the printhead into the carriage and check the control-panel message.
4. If the problem persists, restart the printer.
5. If the problem persists, insert a new printhead.
6. If the problem persists, there may be a problem with the printer, rather than with the printhead.

Cannot insert a printhead

If you encounter this situation, perform the actions described here.

1. Check that you have the correct type of printhead (model number).
2. Check that you have removed the orange protective caps from the printhead.



NOTE: Optimizer printhead caps are white or transparent.

3. Check that the colored label on the printhead is the same color as the label on the slot.
4. Check that the printhead is correctly oriented (compare with the others).
5. Check that you have closed and latched the printhead cover.

Cannot insert the maintenance cartridge

There are various reasons why you may not be able to insert the maintenance cartridge.

- It is the wrong type of cartridge (check the model number).
- It is not correctly oriented.
- It is a reused cartridge.
- It is dirty.
- It has broken parts.
- If the rollers are blocked, use a new maintenance cartridge.

- The ink collection unit is not properly is damaged or not properly installed.

14 Troubleshoot other issues

This section provides operational advice regarding potential issues not previously covered in the User Guide.

The printer does not start

The following steps provide the complete procedure for this topic.

1. Check that the power supply to the printer is working.
2. Ensure that the main power cables are fully plugged in and the PC switch is on.
3. Check that the main power lights are on.
4. Check that the IPS is working with no alerts showing.
5. Try unplugging both power cords and plugging them in again after 10 seconds.
6. If the problem persists, contact your service representative.

The printer cannot be restarted from the Internal Print Server

In rare cases, the printer may be unresponsive to the **Shutdown** and **Wake up** buttons. If this happens, turn off the main switch, then turn it on again after 10 seconds and restart the built-in computer.

The Internal Print Server cannot detect the printer

If the Internal Print Server cannot establish communication with the printer, without apparent reason or after modifying Windows properties, follow these steps:

1. Use the **Wake up** button in the **Tools** menu to try to reactivate the printer.
2. Unplug the main power cords,, then plug them in again after 10 seconds and restart the built-in computer.
3. Check the cable connecting the built-in computer to the printer.
4. Check that the Internal Print Server is correctly set up.
5. Contact your service representative.

Printer is not printing

If a file you have sent from your computer is not printing when expected, the possible reasons include the following.

- Check that the curing module, and maintenance cartridge doors are closed.

- There may be a problem with the electrical power. If the printer is not performing and the control panel does not respond, check that the power switch at the rear is on, the power cords at the rear are correctly connected, and the electrical socket is providing power.
- The network cable is disconnected, or you have problems with your communications setup. See [Communication failures between computer and printer on page 200](#), or contact your IT department or communications system provider.
- Check all the alerts on the control panel. The alerts may explain why printing has stopped, such as:
 - An ink supply is empty.
 - A printhead is missing or damaged.
 - The substrate is mispositioned.
- The roll has a length tracking option activated. Check that the remaining length of your roll is enough for your job.
- The printer and your RIP software have a special feature to predict the ink consumption of your job and estimate whether there is enough ink in your supplies to print the job. Check in your RIP software whether the ink estimation option is activated, and the estimation status for your job (the details of this operation may vary depending on your RIP software).
- In some very unlikely scenarios, the substrate preset you are using may be corrupted due to transfer synchronization issues. Try printing with a generic preset; if this prints well, you can fix the problem by deleting the troublesome preset from the substrate library in the control panel and the RIP software. Then reinstall the substrate, either manually or from the online search in the control panel.
- Unusual electromagnetic phenomena may exist, such as strong electromagnetic fields or severe electrical disturbances. Such occurrences can cause the printer to behave strangely, or even stop working. Turn off the printer by using the power button on the control panel, wait until the electromagnetic environment has returned to normal, then turn the printer on again. If the problems persist, call your service representative.

Printer seems slow

Here are some possible explanations for slow printer performance.

- If you request the highest possible print quality in the RIP, printing will be relatively slow compared with draft-quality printing.
- Check that the substrate loaded in the printer belongs to the substrate category that appears on the control panel.
- Is your printer connected to a network? Check that all components used in the network (network interface cards, hubs, routers, switches, and cables) are capable of Gigabit Ethernet operation. Is there a lot of traffic from other devices on the network? Is the proxy server configured correctly in your printer? Are the printer's required ports accessible from your RIP host?
- Are the printheads in good condition? Printing time tends to increase when a printhead needs cleaning. Check the printhead status on the control panel. Clean or replace printheads if necessary.
- Does your image contain high-density black fills? That may increase printing time.

See also [Printer status and alerts on page 23](#).

Communication failures between computer and printer

Symptoms and solutions for communication failures between the computer and printer.

Some symptoms are:

- The control-panel display does not show the **Receiving** message when you have sent an image to the printer.
- The printer displays an error message while printing, such as error 0090-0007-0089 or 0090-0007-0096. See [System error codes on page 200](#).
- Your RIP stalls when transferring data.

To solve a communication problem:

- Make sure that you have selected the correct printer in your RIP.
- Check that your printer network settings are correctly configured.
- Check that the printer's required ports are accessible from your RIP host.
- Remember that large images usually require more time to receive, process, and print.
- If the printer is connected to your RIP through any other intermediate devices, such as switch boxes, buffer boxes, cable adapters, or cable converters, remove the intermediate device and try connecting the printer directly to your computer.
- Try changing the I/O timeout, which specifies the time that an idle connection is allowed to remain open when the printer is waiting for a remote computer. The default value is 270 seconds.

If these suggestions do not solve your problem, try connecting your RIP host system directly to the printer, with a point-to-point connection. Use the DHCP network configuration in the printer.

System error codes

The control panel may occasionally display a system error, consisting of a numerical code of 12 digits followed by the recommended action that you should take.

In most cases you will be asked to restart the printer. When the printer starts, it can diagnose the issue better and may be able to fix it automatically. If the problem persists after restarting, contact your service representative and be ready to give the numerical code from the error message. If the error message contains some other recommended action, follow the instructions.

Reading a system error code

System error codes explain which component or system is failing, and what action should be taken to resolve the problem.

System error codes have been defined in the format D0XX-nnYY-mmZZ.

Table 14-1 Values of D (device)

| Value | Device |
|-------|-------------|
| 0 | Printer |
| 1 | Accessories |

Table 14-1 Values of D (device) (continued)

| Value | Device |
|-------|---------------------------------|
| 8 | Internal printer firmware error |
| 9 | Internal host software error |

Table 14-2 Values of XX for device 0 (printer)

| Value | Device |
|-------|-------------------------------|
| 01 | E-box |
| 10 | Power management |
| 11 | Pipeline and trailing cable |
| 16 | Curing |
| 17 | Drying |
| 21 | Service station |
| 22 | Ink delivery system |
| 27 | Printheads |
| 30 | Vapor removal |
| 43 | Substrate vacuum |
| 45 | BIOS, formatter, hard disk |
| 46 | Printer ID |
| 47 | Printhead cleaning roll |
| 55 | Carriage line sensor |
| 58 | Carriage color sensor |
| 65 | Substrate path |
| 80 | User interface |
| 86 | Scan-axis system and carriage |
| 88 | Printhead primers |
| 90 | Internal firmware |
| 99 | System |

0027-0001-XX84 and 0027-0001-XX99

These errors indicate printhead voltage issues.

- Replace the printhead. If the problem disappears, the printhead was damaged.
- Otherwise, the problem is in the printer hardware; contact your service representative.

8XXX-XXXX-0000

All system errors with the format 8XXX-XXXX-0000 are firmware assertion failures, which are usually fatal: the system stops working.

They occur very rarely, because they are unanticipated error conditions. After one of these has been reported to HP and analyzed, it is no longer entirely unanticipated, so it is less likely to occur again.

After restarting the printer, your first step should be to make sure you have the latest firmware version: update it if necessary, which may solve the problem. If the problem persists, please contact your HP service representative.

Program slows down or stalls while generating the print job

Check that your computer meets the RIP software minimum system requirements.

Large quantities of data are required to generate a high-quality large-format print job, which can cause your software to slow down significantly or stall. Lowering the print resolution may help to avoid this problem; however, lowering the print resolution reduces print quality.

15 Customer Self-Repair parts

HP's Customer Self-Repair program offers our customers the fastest service under either warranty or contract. It enables HP to ship replacement parts directly to you (the end user) so that you can replace them. Using this program, you can replace parts at your own convenience.

Convenient, easy to use

- An HP Support Specialist will diagnose and assess whether a replacement part is required to address a defective hardware component.
- Replacement parts are express-shipped; most in-stock parts are shipped the very same day you contact HP.
- Available for most HP products currently under warranty or contract.
- Available in most countries.

For more information about Customer Self-Repair, see <http://www.hp.com/go/selfrepair/>.

List of Customer Self-Repair parts

This section provides the complete information.

Where to find instructions for replacing Customer Self-Repair parts

Where you can find the instructions for the self-repair operations.

A comprehensive flyer containing step-by-step instructions is included in the box with your equipment. Please refer to this flyer for detailed guidance.

Your equipment is equipped with an on-screen guide that provides instructions for replacing parts. Follow these steps to access the on-screen instructions:

1. Navigate to the **Maintenance** menu.

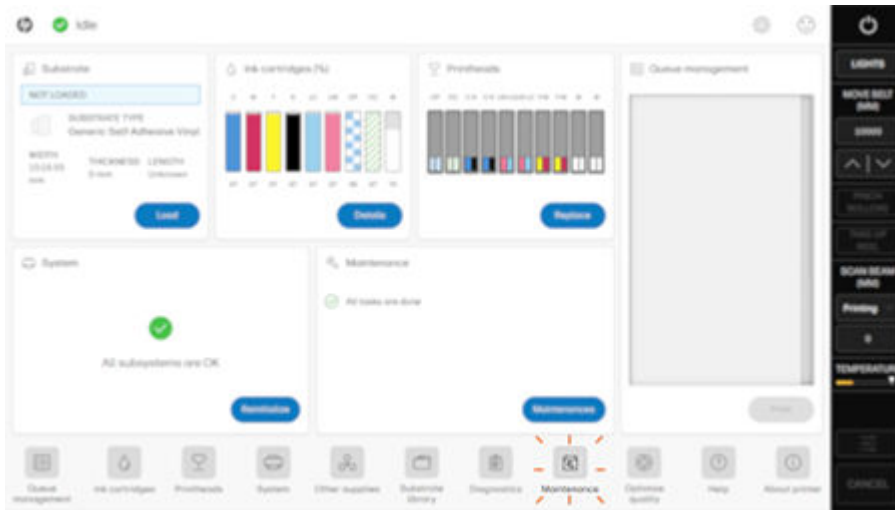

2. Select **Part replacement**.

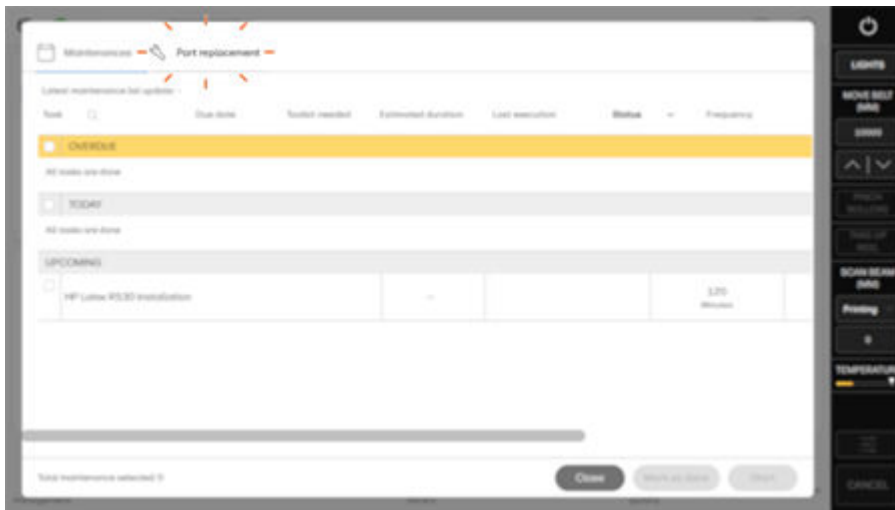

3. Select the part to be replaced from **Tasks** list (1), then select the **Start** button to execute the step-by-step guide (2).

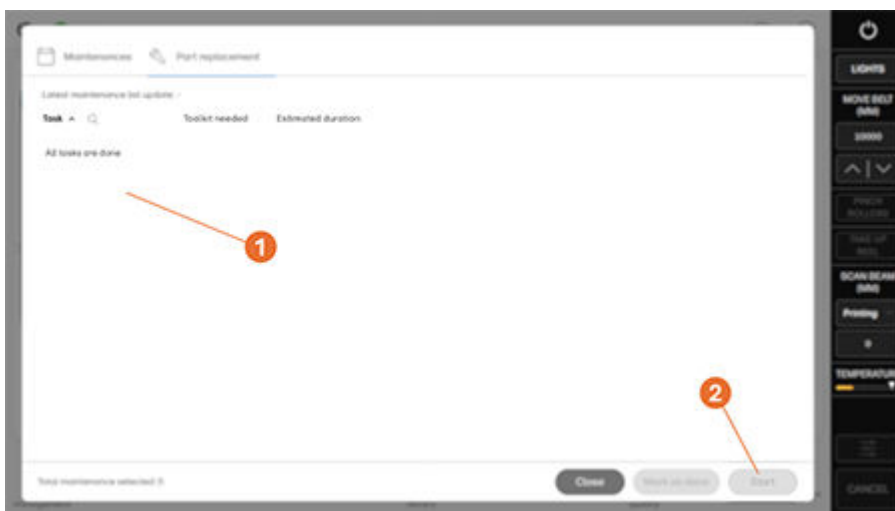

You can access detailed instructions for each self-repair by scanning the QR codes provided below or by clicking the corresponding links. These resources will guide you through the replacement process.

Table 15-1 Online content

| Repair kit | Link to content | QR code |
|----------------------|-----------------------------------------------------------------------------------------------------------------------|---------------------------------------------------------------------------------------|
| Lateral bars | http://www.hp.com/go/Latex/CSR/Lateral_bars |  |
| Transmission plate | http://www.hp.com/go/Latex/CSR/Transmission_Plate |  |
| Table latch | http://www.hp.com/go/Latex/CSR/Table_latch |  |
| Input latch hook | http://www.hp.com/go/Latex/CSR/Input_latch_hook |  |
| Output latch hook | http://www.hp.com/go/Latex/CSR/Output_latch_hook |  |
| Crash sensor rubbers | http://www.hp.com/go/Latex/CSR/Crash_Sensor_Rubbers |  |

Table 15-1 Online content (continued)

| Repair kit | Link to content | QR code |
|-----------------------|-------------------------------------------------------------------------------------------------------------------------|---------------------------------------------------------------------------------------|
| Curing output roller | http://www.hp.com/go/Latex/CSR/Curing_Output_Roller |  |
| Curing side seals | http://www.hp.com/go/Latex/CSR/Curing_Side_Seals |  |
| Drying fan | http://www.hp.com/go/Latex/CSR/Drying_Fan |  |
| Window | http://www.hp.com/go/Latex/CSR/Window |  |
| Window glass | http://www.hp.com/go/Latex/CSR/Window_Glass |  |
| Window sealing gasket | http://www.hp.com/go/Latex/CSR/Window_Sealing_Gasket |  |

Table 15-1 Online content (continued)

| Repair kit | Link to content | QR code |
|---------------------------------|---------------------------------------------------------------------------------------------------------------------------------|---------------------------------------------------------------------------------------|
| Service station door | http://www.hp.com/ctg/Manual/c08416569.pdf |  |
| Carriage cover | http://www.hp.com/ctg/Manual/c08416573.pdf |  |
| Media input loading tray | http://www.hp.com/go/Latex/CSR/MediaInput_LoadingTray |  |
| N-up beam | http://www.hp.com/go/Latex/CSR/NUp_Beam |  |
| Hold-down plate lateral holders | http://www.hp.com/go/Latex/HoldDownPlate_Lateral_holders |  |
| Hold-down plate | http://www.hp.com/go/Latex/CSR/Hold_Down_Plate |  |

Table 15-1 Online content (continued)

| Repair kit | Link to content | QR code |
|--------------------------------|-------------------------------------------------------------------------------------------------------------------------------------------|---------------------------------------------------------------------------------------|
| Hold-down plate protector | http://www.hp.com/go/Latex/CSR/Hold_Down_Plate_Protector |  |
| Condensation collector support | http://www.hp.com/go/Latex/CSR/Condensation_Collector_Support |  |
| Lifting mechanism handle | https://www.hp.com/go/Latex/CSR/LiftingMechanismHandle |  |
| Vapor collector | http://www.hp.com/go/Latex/CSR/vapor_collector_serv |  |
| Beacon | http://www.hp.com/go/Latex/CSR/Beacon |  |
| Removable loading table | http://www.hp.com/ctg/Manual/c08416567.pdf |  |

Table 15-1 Online content (continued)

| Repair kit | Link to content | QR code |
|-------------------------|-----------------------------------------------------------------------------------------------------------------------|---------------------------------------------------------------------------------------|
| Line sensor | http://www.hp.com/ctg/Manual/c08416570.pdf |  |
| Printheads cover | http://www.hp.com/ctg/Manual/c08416555.pdf |  |
| White printheads pocket | http://www.hp.com/ctg/Manual/c08416562.pdf |  |
| 3 in Spindleless hub | http://www.hp.com/ctg/Manual/c08416581.pdf |  |
| Lubrication felts | https://www.hp.com/go/Latex/CSR/LubricationFeltsKit |  |

16 Supplies and accessories

This section supplies further information regarding Supplies and Accessories.

Printer accessories and consumables

The printer is available with a range of accessories and consumables.

Table 16-1 Printer accessories and consumables

| HP Latex R530 | |
|---------------------------|----------------------------------------------------|
| Supplied with the printer | HP Latex R Series Standard Tables |
| | HP Latex R Series Multi-Sheet (N-up) |
| Optional accessories | HP Latex R Series Extension Tables |
| | HP Latex R530 Lateral Pinch Rollers Kit |
| | HP Latex User Maintenance Kit |
| Consumables | HP 837 Universal Latex Printhead |
| | HP 837 Optimizer Latex Printhead |
| | HP 837 White Latex Printhead |
| | HP 833/838 Latex Ink Collection Unit (2-unit pack) |
| | HP 838 Latex Maintenance Cartridge |
| | HP Latex Ink cartridges ^{*1} |

^{*1} Refer to printer's datasheet for regional supplies compatibility.

Disposal instructions

HP provides many free and convenient ways to recycle your used original HP ink supplies. Additionally, HP provides a free program for business customers to return signage printed using selected eligible and recyclable HP large-format substrates.

For more information about these HP programs, see <http://www.hp.com/recycle>.

For your printer, the following items can be recycled through the HP Planet Partners program:

- HP 837 Series Latex Printheads
- HP recyclable large-format substrates
- HP Sign and Display large-format substrates—recyclable or eligible for return through the HP Large Format Media take-back program

 **NOTE:** Visit <http://www.hp.com/recycle> for details of the HP Planet Partners program: features, availability, and how to participate. The program may not be available in your area. Where this program

is not available, consult the Material Safety Data Sheet (MSDS) available at <http://www.hp.com/go/ecodata/> to determine the appropriate method of disposal.

NOTE: Recyclable HP substrates can be recycled through commonly available recycling programs, or according to region-specific practices. Some HP substrates are eligible for return through the HP Large Format Media take-back program, which may or may not exist in your area. See <http://www.HPLFMedia.com/hp/ecosolutions/> for details.

HP Latex Eco-Carton Ink Cartridges for the HP Latex R530 series printers should be disposed of by following the instructions on the cartridge packaging.

Dispose of the following supplies and accessories in compliance with federal, state, and local regulations:

- HP Latex Maintenance Cartridge
- HP Latex Ink Collection Unit

HP recommends that you wear gloves when handling the maintenance cartridge, the platen, condensates, and the condensation system components.

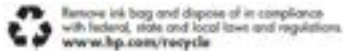

Accessories

This section provides the complete information.

Extension tables

The following steps provide the complete procedure for this topic.



A extra pair of input and output tables for rigid substrate handling can be purchased as an accessory. When properly assembled and attached to the ends of the standard tables provided with the printer, the extension tables enable safe and reliable handling of large substrate sheets.

- CAUTION:** The weight of the substrate should not exceed 60 kg (132 lb).
- CAUTION:** Do not use the tables as a place to store substrate.
- CAUTION:** The standard and accessory extension tables are intended for use only when attached to the printer as described in these instructions. When not in use, the tables should be stored with the

table tops folded in the storage position. Use caution when operating the table tops and moving the tables, to avoid personal injury or damage to property.

 **NOTE:** If the accessory tables were properly leveled when they were installed, they should not need to be leveled again. If substrate feed problems occur, make sure the accessory tables are securely latched to the standard tables, and verify that the tables are level. Check first that the fixed support assembly is level, then check the folding support, and adjust the table wheels up or down as necessary.

During use, the extension tables must be latched to the standard tables for safety and best print quality.

1. To connect the extension tables to the standard tables, take an extension table and place it in front of the one already installed on the printer.



2. Locate the docking element at each end of the table.

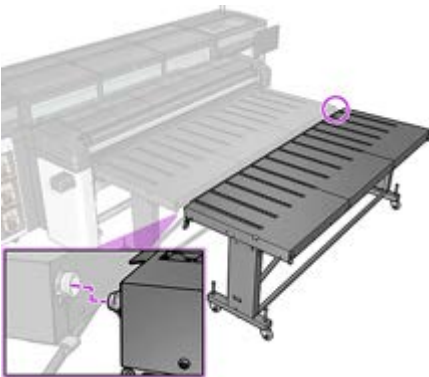

 **NOTE:** You can use an extension table on either side of the printer, but always connected to a standard table, not connected directly to the printer.

3. Turn the front-wheel knob until the docking elements align.

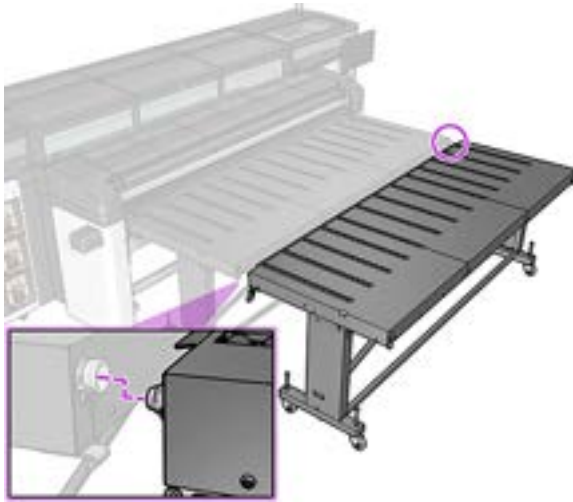

4. Once the connector is inserted, close the latch to fix it in place. Repeat the process at the other side of the table.

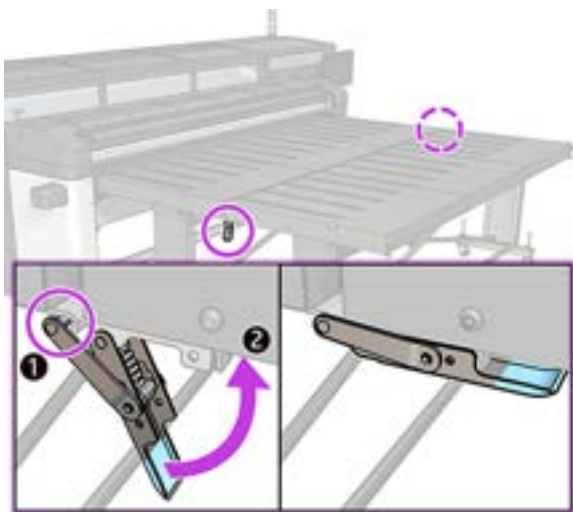

5. Once the front side of the table is fixed to the printer, use the rear-wheel knob to level the table. Use the bubble level installed at each end of the table as a reference.

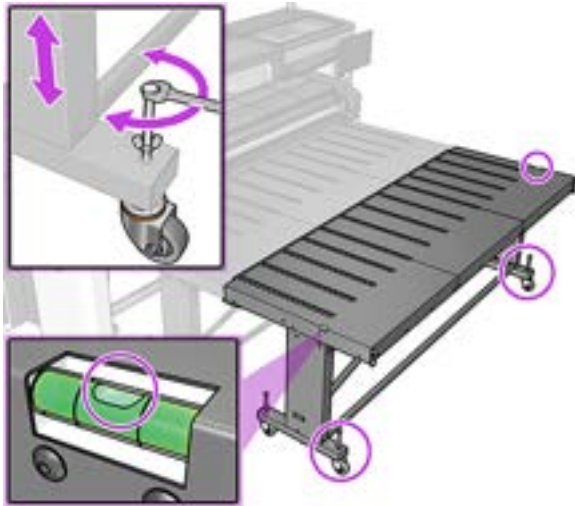

TIP: If you need to access the input print zone, you can unlatch one side of the extension table and move this side away. Put back the table and latch to continue working as usual.

Extension tables must be stored folded when not in use. Pull the blue cord at the bottom to allow the table to move, and turn the table upright.

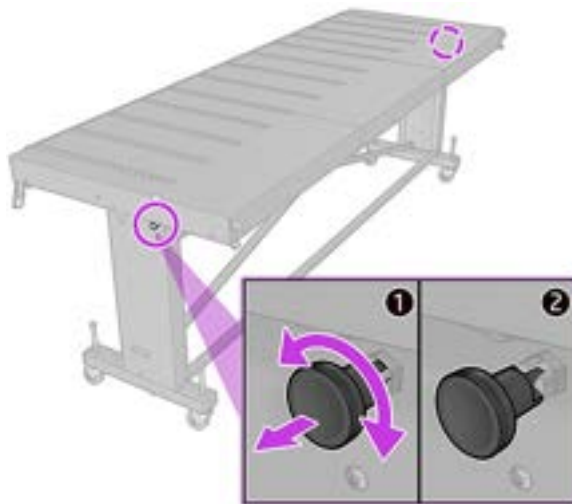

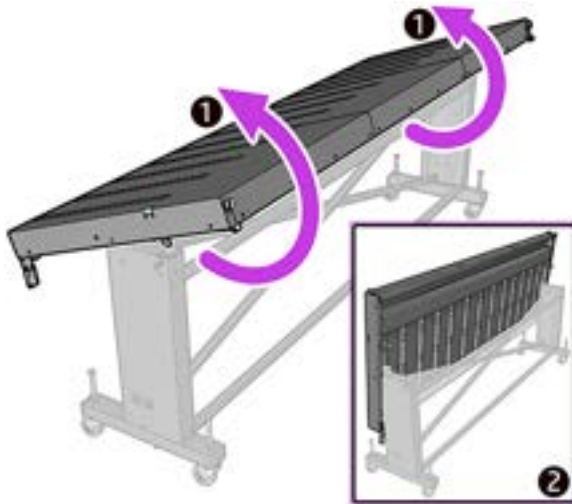

Lateral pinch wheels

The lateral pinch wheels help prevent the side edges of rigid substrates from lifting and causing jams during printing. If you encounter this issue, try using the lateral pinch wheels to resolve it. Follow the steps to activate or deactivate the pinch wheels.

1. Load the substrate using the standard procedure.
2. After loading, go to the output side of the printer and locate the lateral pinch wheel levers near the print zone window.
3. Lift the lever on the IPS side to activate the first lateral pinch wheel.
4. Slide the second wheel (on the Beacon side) so it aligns with the opposite edge of the substrate.
5. Ensure both wheels cover at least 10 mm of substrate width.
6. After printing, if continuing with boards of the same type and size, you can leave the pinch wheels activated and in place. If you want to print on another substrate type or size, you only have to lower the lever to deactivate the lateral pinch wheels.

When to use pinch wheels:

- Recommended for printing on plastic solid substrates thicker than 2 mm and wider than 1000 mm.
- Useful when board deformation is present at the side edges or leading edge.

17 Move or store the printer

If it becomes necessary to relocate the printer to a new point of operation or for storage purposes, care must be taken to ensure future functionality is not compromised.



Move the printer to a location on the same floor

If you need to move your printer, prepare it correctly to avoid possible damage.

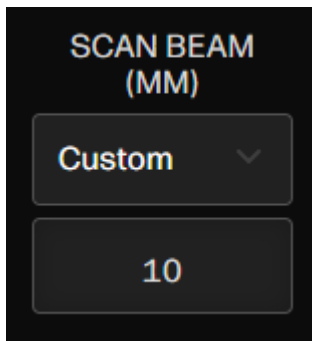
1. Remove all ink cartridges (see [Remove an Eco-Carton ink cartridge on page 95](#)) and the maintenance cartridge; unload all substrate.
2. Make sure you empty the condensation collector. Remember to connect the cap to the condensation collector after emptying it.
3. Remove the printheads from the carriage and store them with their caps on.
4. Remove the Maintenance cartridge and store it in horizontal position to avoid ink spills.
5. Make sure that the printhead carriage is located at the right of the print zone, and blocked with the orange lock saved from the printer installation.
6. Set the **SCAN BEAM** to 10 mm



7. Turn off the power by using the power button on the IPS.
8. Disconnect any cables that connect the printer to the power and network.
9. For correct environmental storage conditions, see [Environmental specifications on page 223](#).
10. Make sure that all stand screws are tightened to a recommended torque of 2.8 N·m (25 lbf·in).
11. Place the ink supply tray in its moving position. For more information, see [Preparing the ink supply tray on page 217](#).
12. After preparing the printer to prevent damage, raise its three feet so it rests on the wheels.
13. Release the wheel brakes, and the printer will be ready to move.

14. To prevent damage during transportation, avoid pushing the covers marked with  in the image below. Instead, push the covers marked with .



 **NOTE:** Four people are required to move the printer to the final position.

 **NOTE:** If the printer or ink cartridges are moved from a cold location to a warm and humid location, water from the atmosphere can condense on the printer parts and cartridges and can result in ink leaks and printer errors. In this case, HP recommends that you wait at least 3 hours before turning on the printer or installing the ink cartridges, to allow the condensation to evaporate.

Preparing the ink supply tray

When moving a printer, it is necessary to properly prepare the ink supply tray.

1. Remove the screw on top of the lifting pieces, situated at left and right of the rear of the printer, then remove the lifting pieces from the printer.

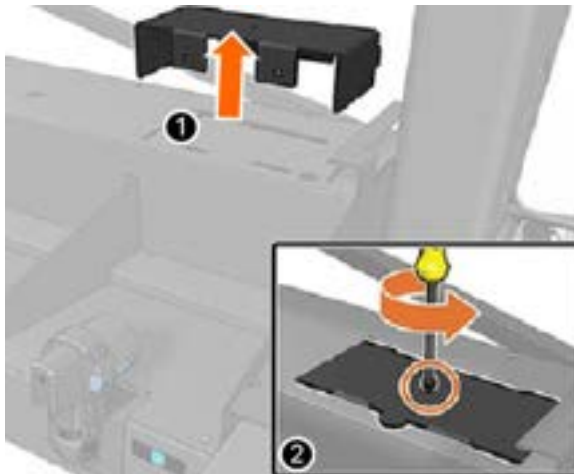

2. Remove the screws from the ink supply tray.

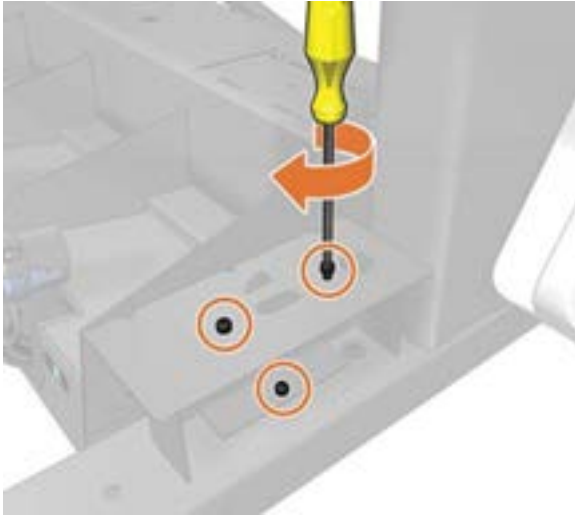

3. Using the tray handle, lift the ink supply tray, and place the lifting piece under the tray.

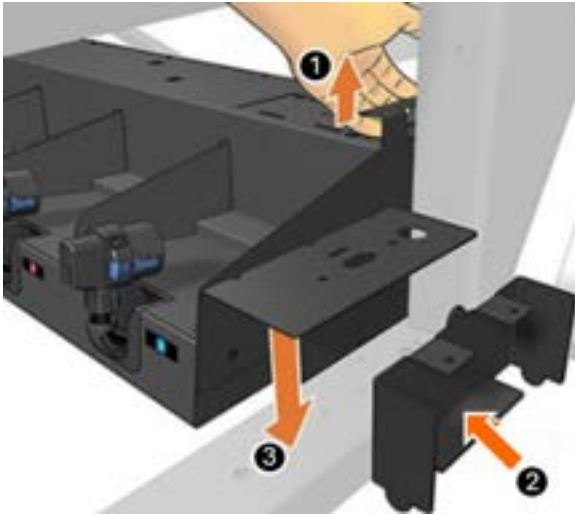

4. Screw the lifting piece tightly to the tray, using the same screws that you removed from it earlier, with a recommended torque of 2.8 N·m (25 lbf·in).

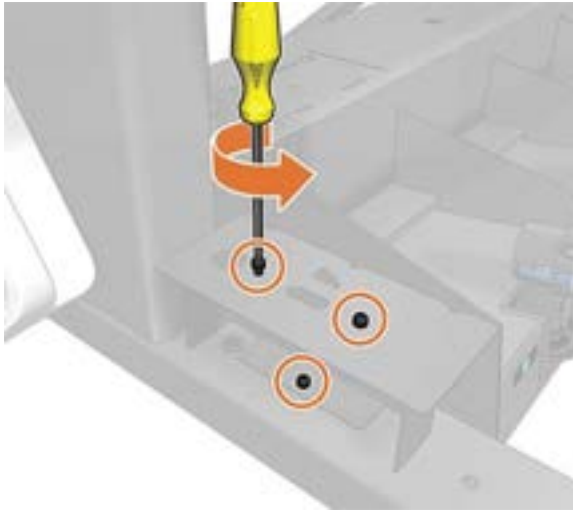

5. Repeat the same process on the other side of the printer.

Repeat the same process in the opposite order to take out the lifting pieces and store them in the storage position.



TIP: HP recommends starting on the right of the printer, to adjust the ink supply tray correctly in its printing position.

Move the printer over obstacles or with special transportation

If the printer needs to be relocated over obstacles or transported using special equipment, contact your service representative to ensure proper preparation and prevent damage.

Store the printer

If you need to store your printer for an extended period of time, prepare it correctly to avoid possible damage:

The printer should never be turned off; use sleep mode instead.

Automatic white-ink maintenance cannot occur when the printer is completely powered down, and white-ink printheads cannot last more than eight hours without maintenance.

If you need to store the printer without power, contact your service representative to prepare it properly and prevent damage.

Storage outside environmental specifications

If you need to store the printer in conditions outside the environmental specifications contact your service representative..

See [Environmental specifications on page 223](#).

18 Printer specifications

Here you can find the functional, physical, memory, power, ecological, environmental, and acoustic specifications of your HP Latex R530 Series printer.

Functional specifications

Details of the ink cartridges, ink supplies, substrate sizes, printing speeds, maximum print resolution, and printing margins of the printer.

Ink cartridges

- HP Latex R530 series printers: Eight 3 liter HP Eco-Carton ink cartridges, one for each color (black, cyan, magenta, yellow, light cyan, light magenta, optimizer, and overcoat).

Additionally, one 3 liter HP white Eco-Carton ink cartridge.

Table 18-1 Ink supplies

| Device | Specifications |
|------------------------------------------------|--------------------------------------------------------------------------------------------------------------------------|
| Printheads | Cyan/Black, Yellow/Magenta/Light Magenta/Light cyan and Overcoat. Specific Printheads for White ink Latex and Optimizer. |
| Ink cartridges | Yellow, black, magenta, light magenta, cyan, light cyan, overcoat, optimizer and white. |
| Maintenance cartridge, and Ink Collection Unit | Non-color-specific |

Table 18-2 Substrate sizes

| - | Minimum | Maximum |
|--------|----------------------------------------------------|---------------------------------------------------------|
| Width | 457 mm (18 in) Narrow substrate: 254 mm (10 in) | 1626 mm (64 in) |
| Length | 1.5 m (59 in) | Roll with maximum external diameter of 275 mm (10.8 in) |
| Weight | | 55 kg (121 lb) |

The printer supports a substrate core diameter of 76.2 mm (3 in).

Table 18-3 Printing speeds

| Pmode | Media | Sust. Xput full width (m2/h) | 4x8 ft boards per hour |
|-------|-------|------------------------------|------------------------|
| 4p | All | 31 | 7.6 |
| 6p | All | 24 | 5.9 |

Table 18-3 Printing speeds (continued)

| Pmode | Media | Sust. Xput full width (m ² /h) | 4x8 ft boards per hour |
|---------------|--------------------------|-------------------------------------------|------------------------|
| 12p | All* | 15.6 | 3.8 |
| | Solid plastic | 14.0 | 3.0 |
| 16p | SAV, PVC foam, cardboard | 11.6 | 2.8 |
| | ACP & solid plastic | 9.8 | 2.0 |
| W Spot 100 | SAV and others | 9.2 | 2.2 |
| | Solid plastic | 8.4 | 1.7 |
| W OF100 | SAV and others | 6.2 | 1.51 |
| | Solid plastic | 5.8 | 1.11 |
| W UF100 | SAV and others | 4.2 | 1.03 |
| | Solid plastic | 3.9 | 0.77 |
| W UF160 | SAV and others | 3.1 | 0.76 |
| | PVC foam | 2.6 | 0.63 |
| W SW 3L (160) | SAV | 2.1 | 0.51 |
| | Plastic solid | 1.9 | 0.37 |
| W SW 5L | SAV | 1.4 | 0.29 |
| | Solid plastic | 1.2 | 0.25 |

 **NOTE:** Environmental conditions, job length, and ink density influence the maximum speed you can achieve with a particular print mode.

The maximum print resolution of the printer is 1200 × 1200 dpi. See your RIP documentation to find the resolutions supported by your RIP.

Table 18-4 Margins

| Margin | Size |
|-------------------------------|----------------------------------------------------|
| Side margins | 5 mm (0.2 in), or 10 mm (0.4 in) with edge holders |
| Top margin (leading edge) | 5 mm (0.2 in) |
| Bottom margin (trailing edge) | 5 mm (0.2 in) (none) |
| | 100 mm (3.9 in) (small) |
| | 150 mm (5.9 in) (normal) |
| | 200 mm (7.9 in) (extra) |
| | 300 mm (11.8 in) (extra) |
| | 400 mm (15.7 in) (extra) |
| | 500 mm (19.7 in) (extra) |

Physical specifications

Details of the length, width, height, and weight of the printer, with and without packaging.

Table 18-5 Physical specifications with packaging

| Printer model | Length | Width | Height | Weight |
|---------------|--------------------|-------------------|-------------------|-------------------|
| R530 | 2933 mm (115.4 in) | 2226 mm (87.6 in) | 1756 mm (69.1 in) | 1256 kg (2769 lb) |

Table 18-6 Physical specifications without packaging

| Printer model | Length | Width | Height | Weight |
|---------------------|--------------------|-------------------|-------------------|------------------|
| R530 without tables | 2628 mm (103.5 in) | 1730 mm (68.1 in) | 1546 mm (60.9 in) | 660 kg (1455 lb) |
| R530 with tables | 2628 mm (103.5 in) | 3200 mm (126 in) | 1546 mm (60.9 in) | |

Memory specifications

Details of the physical memory and Hard Disc capacity of the printer.

Table 18-7 Memory specifications

| Memory | Specifications |
|--------------------------------|----------------|
| Printer physical memory (DRAM) | 8 GB |
| Printer hard disk | 500 GB |
| IPS physical memory | 8 GB |
| IPS hard disk | 250 GB |

Power specifications

Details of the Single phase line specifications of the printer.

Table 18-8 Single phase line specifications

| | HP Latex R530 series |
|---------------------------------------------------|--------------------------------------------|
| Number of power cords | 2 |
| Input voltage | 200-240 V (two wires and protective earth) |
| Input frequency | 50 / 60 Hz |
| Maximum load current (per power cord) | Printer: 16 A Curing: 16 A |
| Power consumption per power cord in printing mode | Printer: 2.5 kW Curing 2.5 kW |
| Power consumption in ready mode | 130 W |

HP latex R530 series has to be connected on TN or TT power systems

Ecological specifications

For the up-to-date ecological specifications of your printer, please go to www.hp.com and search for "ecological specifications".

<http://www.hp.com/>

Environmental specifications

Details regarding the humidity, temperature, and altitude thresholds for correct operation of the printer.

Table 18-9 Printer environmental specifications

| Type | Value |
|------------------------------------------------|------------------------------------------------------|
| Relative humidity range for best print quality | 40–60%, depending on substrate type |
| Relative humidity range for printing | 20–80%, depending on substrate type |
| Temperature range for best print quality | 20 to 25°C (68 to 77°F), depending on substrate type |
| Temperature range for printing | 15 to 30°C (59 to 86°F), depending on substrate type |
| Temperature range when not in operation | –10 to +55°C (+14 to +131°F) |
| Temperature gradient | no more than 10°C/h (18°F/h) |
| Maximum altitude when printing | 3000 m (10000 ft) |

 **NOTE:** The printer must be kept indoors.

 **NOTE:** If the printer or ink cartridges are moved from a cold location to a warm and humid location, water from the atmosphere can condense on the printer parts and cartridges and can result in ink leaks and printer errors. In this case, HP recommends that you wait at least 3 hours before turning on the printer or installing the ink cartridges, to allow the condensation to evaporate.

Acoustic specifications

Details of the sound pressure and sound power of the printer.

Table 18-10 Printer acoustic specifications

| Printer state | Sound pressure |
|--------------------------|----------------|
| Operating Sound Pressure | 65 dB(A) |
| Idle Sound Pressure | < 60 dB(A) |

Maximum sound pressure levels at by-stander positions according to ISO 11202.

A Summary of common printing problems

This is a table of common problems and the parameters that can be changed in order to solve the problem. Some possible side-effects are also shown. For a more detailed treatment of any particular problem, please see the relevant chapter in this guide.

Table A-1 Common printing problems

| Problem | Parameter | Change | Possible side-effects |
|----------------------------------------------------|---------------------------------|----------|---------------------------------------------------------------------------------------------------------------------------------------------------------------------------------|
| Durability problems, ink smudges, or oily finish | Curing temperature | Increase | Substrate jam, substrate damage, ink smears |
| | Number of passes | Increase | Slower printing |
| | Inter-pass delay offset | Increase | Slower printing |
| Substrate jam, substrate damage, ink smears | Curing temperature | Decrease | Less durability (smudges), oily finish |
| | Vacuum | Increase | Substrate skew, vertical banding if increased too much |
| | Top and/or bottom margins | Increase | Waste of substrate |
| | Edge holders | Use | The minimum side margins increase slightly, reducing the maximum width of the printed image |
| Vertical banding | Vacuum level | Decrease | Substrate jam |
| | Take-up reel | Use | |
| Horizontal banding | Clean printheads | | |
| | Number of passes | Increase | Slower printing |
| | Clean substrate-advance sensor | | |
| | Inter-pass delay offset | Increase | Slower printing |
| Coalescence graininess in low-to-medium area fills | Align printheads | | |
| | Number of passes | Increase | Slower printing |
| | Optimizer level | Increase | Reduced gloss in dark area fills. With some substrates, may have no effect on coalescence. Consider using the advanced optimizer check plot to select the best optimizer level. |
| | Efficiency mode | Disable | More ink consumption |
| | Dirty roll or defective coating | | Consider trying a new roll. Some substrates deteriorate during long periods of storage. |

Table A-1 Common printing problems (continued)

| Problem | Parameter | Change | Possible side-effects |
|------------------------------------------------------------|-----------------------------------------------------------------------------------|-----------------------------------------------------------------------------------------------------------------------------------------------------------------------------------|----------------------------------------------------------------------------------------------------|
| Graininess, color misregistration or lack of sharpness | Align printheads | | |
| | Clean substrate-advance sensor | | |
| | Disable the substrate-advance sensor and calibrate the substrate advance manually | NOTE: Some substrates (porous/translucent/transparent) are not compatible with the substrate-advance sensor, which should be disabled before printing on these substrates. | |
| Black areas look hazy or image gloss is not uniform | Modify color separations and dark color generation | | |
| | Number of passes | Increase | Slower printing |
| | Curing temperature | Decrease | Less durability (smudges), oily finish |
| Bleeding between inks or wicking into white areas | Align printheads | | |
| | Align optimizer manually | If necessary, load a self-adhesive vinyl to achieve good alignment | |
| | Ink limits | Decrease | Reduced color gamut |
| | Optimizer level | Increase | Reduced gloss in dark area fills. With some substrates, may have no effect on bleeding or wicking. |
| | Clean optimizer printhead | | |
| Lack of sharpness in text or solid areas | Align printheads | | |
| | Align optimizer manually | If necessary, load a self-adhesive vinyl to achieve good alignment. | |
| | Color bars | Add, manually or in RIP | Some waste of substrate and ink |
| Subtle color variations in solid areas | Color bars | Add, manually or in RIP | Some waste of substrate and ink |
| | Color-variation and text-line correction | Apply | White areas may appear slightly different. |
| Vertical gloss banding reproducing impinging hole patterns | Check that all curing module cleaning maintenances have been done. | | |
| | Amount of optimizer ink | Reduce | Risk of ink bleeding |
| | Curing Height Increase Risk of curing capacity | Increase | Risk of curing capacity |

B Rigid substrate recommendations

The rigid substrate types described in this appendix are compatible with your printer.

Corrugated plastic

Also known as corrugated or fluted polypropylene

Applications

- Temporary outdoor signage
- Lightweight and versatile material made from polypropylene or polyethylene
- Consists of three layers: two flat outer layers (liners) and a middle layer of perpendicular flutes or ribs, creating a hollow, corrugated structure
- Most common thicknesses: 3-5 mm

Media types

- Fluted structure: Suitable for “H” stake applications, cost-effective, visible flute marks on the surface
- Bubbled structure: Higher rigidity, even surface, premium quality

Sustainable choice

- Look for materials with recycled PP content

Printing recommendations/challenges:

- Easy to print using generic presets with good results
- Matte finishes may appear less saturated; increase ink density for better color vibrancy
 - Monitor bleed and curing when increasing ink density
- Fluted structure is forgiving for DLZB when bands are placed horizontally

Other recommendations/challenges

- Quality variation: Corrugated polypropylene quality varies. Manufacturers apply corona treatment to enhance ink adhesion, but this effect diminishes over time. Long storage or long-distance shipping may reduce adhesion.
- Static charge: This material tends to hold static. Avoid sliding sheets from the stack or carrying them across carpeted surfaces.
- Squareness: Media is often supplied not squared. Trimming may be necessary for edge-to-edge printing.
- Cutting debris: Leftover material from cutting (even from the provider) may cause white spots. Ensure all edges are clean and free of burrs or excess material.

- Surface cleaning: Use an anti-static tack cloth to remove dust, debris, and static charge before printing.

Paper foamboard

This topic describes: Paper foamboard

Applications

- Indoor retail signage and exhibitions

Media characteristics

- Core made of lightweight polystyrene foam, providing rigidity and thickness without significant weight
- A core sandwiched between layers made of paper or paper-based material, which can be plain, coated, or laminated depending on the finish and application

Media types

- The paper characteristics (finish, coating, embossing, fiber content) greatly impact printability. Due to the wide variety of paper types (finishing, coatings, embossing, fibers, etc.,) it is difficult to define universal printing settings

Sustainable choice

- Foamboard is not environmentally friendly due to its polystyrene core
- Alternative: Choose corrugated cardboard for a more sustainable option

Printing recommendations/challenges:

- Prone to vertical bands related to drying
 - Main knobs to resolve the issue: Increase drying air flow AF, reduce platen temperature (PT), and, if possible, increase curing temperature
- Higher drying AF can increase grain and coalescence
 - Reducing PT may affect bleed but can be balanced by higher drying AF
- High variability in paper coatings and finishes makes it challenging to find universal settings

Other recommendations/challenges

- Store flat in a clean, controlled environment with stable temperature and humidity to prevent warping
- Temperature and humidity changes can cause warping
- Clean with a lint-free cloth to remove dust and debris before printing
- Susceptible to dents and damage—handle carefully, especially around corners and edges to prevent contact with the print carriage

PVC foam

This topic describes: PVC foam

Applications

- Indoor retail signage and exhibitions
- Temporary outdoor signage
- Free Standing Display Units (FSDU) and displays

Media characteristics

- Most common thickness: 2-3 mm
- Color grades available for white ink printing

Media types

- Core made of expanded polyvinyl chloride (PVC), sandwiched between two outer layers of solid PVC sheets
- More durable and resistant to moisture, chemicals, and UV rays than plastic foam board

Sustainable choice

- PVC and PU are not environmentally friendly, but some manufacturers offer recycled-content options

Printing recommendations/challenges:

- Some materials in this category may have low bleed margins, especially in high humidity environments
 - Increase platen temperature (PT) to reduce bleed
- Generic PT settings are conservative to prevent impinging marks, which worsen at higher PT levels
- UF modes may show vertical bands due to insufficient drying in interfan areas at high humidity. To resolve this, increase drying air flow (AF) or add interswath delays

Other recommendations/challenges

- If the media has a protective film, peel off one side before printing, leaving the other side protected until finishing or installation
- If one side is smoother than the other, print on the rougher side for better adhesion
- Wipe the surface with an anti-static tack cloth to remove static and dust before printing

PVC foam

This topic describes: PVC foam

Applications

- Indoor retail signage and exhibitions

- Temporary outdoor signage
- Free Standing Display Units (FSDU) and displays

Media characteristics

- Similar to PVC foam, but the core differs from the outer layers
- Most common thickness: 2-10 mm
- Typically available in white

Media types

- Core made of polystyrene or polyurethane, sandwiched between two outer plastic sheets
- Resists bending and warping, providing a sturdy surface

Sustainable choice

- Multilayered structure complicates recyclability
- PVC and PU are not sustainable, but some manufacturers offer recycled-content options

Printing recommendations/challenges

- Some materials in this category may have low bleed margins, especially in high humidity environments
 - Increase optimized platen temperature (OPT) to reduce bleed
- Generic OPT settings are conservatively low to prevent impinging marks, which worsen at higher OPT levels

Other recommendations/challenges

- If the media has a protective film, peel off one side before printing, leaving the other side protected until finishing or installation
- If one side is smoother than the other, print on the rougher side for better adhesion
- Wipe the surface with an anti-static tack cloth to remove static and dust before printing

ACP

This topic describes: ACP

Applications

- Outdoor signage
- Indoor decoration

Media characteristics

- ACP consists of two thin aluminum sheets bonded to a non-aluminum core
- The most common core material is polyethylene (PE), making it lightweight and flexible
- Printing grades usually feature a polymeric top-coat to enhance ink adhesion

- A more sustainable alternative uses a corrugated aluminum core instead of PE

Sustainable choice

- Recycling ACP is difficult due to its multilayer composition
- 100% aluminum composite panels (with a corrugated aluminum core) offer a more sustainable alternative

Printing recommendations/challenges

- Balancing bleed, impinging marks, and grain is challenging
 - Higher OPT reduces bleed but worsens impinging marks
 - Higher Drying AF reduces bleed but increases grain

Other recommendations/challenges

- Ensure the media is completely flat, with no damaged corners, edges or ends before printing; manually flatten if necessary using a metallic tool
- Use clean cotton gloves to prevent fingerprints
- Avoid stacking sheets and handle carefully, as both media and ink are prone to scratching

Known limitations

Ink durability on ACP is lower than on self-adhesive vinyl (SAV) or competitor materials

Recommendations for ink durability

Outdoor or High-Traffic Applications

- Cold lamination required
 - Polymeric laminate: Up to 4 years light fastness
 - Monomeric laminate: Up to 2 years light fastness

Indoor low-traffic applications

- Cold lamination required
 - Monomeric laminate: Up to 2 years light fastness

Solid plastic

This topic describes: Solid plastic

Applications

- Indoor retail signage and exhibitions
- Outdoor signage
- Indoor decoration

Media characteristics

- These boards are made from various plastics, each offering unique properties suited for specific uses

Media types

- Polycarbonate (PC)
- Acrylic (PMMA)
- Polyester (PET-G, PET-A)
- Polystyrene (HIPS)
- Most types are available in clear, translucent, or opaque versions
 - Clear and colored opaque are mainly used for white print modes
 - Opaque white is ideal for frontlit applications
 - Translucent grades are suited for backlit applications

Sustainable choice

- Some media vendors offer recycled grades of these materials
- Post-consumer waste recycled content is more sustainable than post-industrial waste
- Bio-polymers made from renewable raw materials are also a good sustainable option

Printing recommendations/challenges

- Thermal deformation is a key challenge in this media category
- Generic curing temperature settings are conservatively low to prevent deformation
 - Depending on thickness and material type, temperature needs may be even lower
 - If lower curing temperature is required, interswath delays should be added to ensure proper curing
 - PET plastics are more sensitive to heat than PC or PMMA
- White print modes: Balancing grain performance is challenging
 - Decreasing drying AF may help, but be cautious of bleed if drying AF is too low

Other recommendations/challenges

- Ensure media is flat and has no damaged corners, edges, or ends before printing
- Handle carefully when loading or lifting sheets as both media and ink can be easily scratched
- Additional durability recommendations (primer, top coat, lamination) will be provided soon
- Use clean cotton gloves to prevent fingerprints

Known limitations

Table B-1 Known limitations

| Thickness | Color printmodes | White printmodes |
|-------------------------|------------------------------------------------------|------------------------------------------------------|
| < 1 mm (< 0.04 in) | Not recommended | Not recommended |
| 1-1.5 mm (0.04-0.06 in) | HIPS (width > 1 m: deformations) | Not recommended |
| 1.5-2 mm (0.06-0.08 in) | HIPS (width > 1 m: pinchrollers needed) | Not recommended |
| 2-3 mm (0.08-0.12 in) | HIPS and Acrylics (width > 1 m: pinchrollers needed) | Acrylics (width > 1 m: pinchrollers needed) |
| 3-4.5 mm (0.12-0.18 in) | HIPS and Acrylics (width > 1 m: pinchrollers needed) | Acrylics, PET, PC (width > 1 m: pinchrollers needed) |
| +4.5mm/+0.18inch | No limitation | No limitation |

Uncoated cardstock

This topic describes: PVC foam

Applications

- Free Standing Display Units (FSDU) and displays
- Packaging

Media characteristics

- Paper-based material without a coating layer, giving it a natural, matte, and rougher texture compared to coated boards

Media types

- In R-Series printers, paper-based boards were categorized by structure:
 - Compressed cardboards
 - Corrugated boards
 - Honeycomb boards
- For R530 printers, categorization is based on surface finish rather than structure, because of that, the paper-based boards are categorized as:
 - Coated boards
 - Uncoated boards
- Board structure (honeycomb, compressed, corrugated) is still present but does not impact print settings, so it is not considered a media category in the printer

Sustainable choice

- Uncoated boards are generally a good sustainable choice:
 - Require fewer chemicals and less energy to produce

- Easier to recycle than coated boards due to fewer additives
- Made from renewable paper fibers
- Look for FSC or PEFC certification to ensure responsible forest management

Printing recommendations/challenges

- Uncoated boards generally do not produce colors as sharp or vivid as coated boards because the ink tends to absorb into the paper more. That is why generic print modes have higher ink density (120%) and high PT levels to saturate the surface.
- These materials are highly sensitive to drying conditions, which can cause IQ artifacts (non-homogeneous color saturation).
- Humidity changes can impact media stability:
 - High liquid saturation in thin materials may cause cockling or warping
 - Drying and curing reduce media humidity, potentially causing material contraction. Watch for edges lifting, which may strike the carriage.

Other recommendations/challenges

- Store media flat, in a clean environment with temperature and humidity similar to the printer
- Handle carefully, as the material can bend and crease easily

Known limitations

- Pre-deformed boards can only be printed if deformation is within acceptable limits
- Thin folding cardboards (<0.7 mm) may slip under the alignment bar
 - In this case, raise the media edges to ensure proper alignment
 - Avoid hot loading to maintain accurate registration
- Post-printing deformation can be significant
- Pinch rollers are needed for
 - Kraft honeycomb boards (15 mm thickness)
 - Required for side B printing as side A printing deforms the board
 - Certain cardboards prone to side deformation, such as 3A Dispa boards (>1 m)

Recommendations

- Position boards with raised lateral sides rather than leading or trailing edges
- Single-side printing: Always print on a convex surface, as the vacuum will flatten the media
- Dual-side printing:
 - Start with the convex side, as printing side A will flatten the board
 - Before printing side B, check that deformation does not exceed limitations

Recommended print modes (introduction)

The recommended print modes in this chapter include the print modes that are standard and recommended by HP for a substrate family.

This recommendation is based on HP's internal testing and, in most cases, provides a good starting point for printing on substrates within a specific substrate family. Although HP tests are performed on an extensive set of substrates, there is no guarantee that these settings are suitable for every substrate. Additional, optimized print modes for specific substrates can be created by cloning and modifying an existing one. See [Add a substrate preset on page 81](#) for more information.

Use Sensitive Mode with heat-sensitive substrates

To print in Sensitive Mode, enable the curing lever. When you have finished printing in Sensitive Mode, disable the curing lever.

Some substrates, due to their chemical composition or thickness, can be especially sensitive to the heat produced by the curing module. Examples include PVC foams, and solid plastics thinner than 3 mm.

After such a substrate has been loaded into the printer, the Internal Print Server notifies you, within the substrate widget, that the substrate is potentially sensitive, and that you should set curing to work in Sensitive Mode. Not all print modes can be used in this mode; check that the print mode for the job is supported in Sensitive Mode before printing.

When you tap **Print**, if necessary the printer will give you a final reminder to set Sensitive Mode and choose an appropriate print mode; but you can choose to ignore the reminder.

Predefined substrate settings

This topic provides a full set of reference information for this subject.

Table B-2 Predefined substrate settings

| Substrate type | Feed method | Weight | Detectable by printer | Use rollers | Conductivity | Vacuum fan level | Examples |
|-----------------------------------|-------------|--------|-----------------------|-------------|--------------|------------------|------------------------------------------------------|
| Aluminum composite | Sheet | Light | No | Yes | Yes | Medium | Alumacore, Alupalite, Dibond, Graphic-AL, Omega-Bond |
| Clear sheet | Sheet | Light | No | Yes | No | Medium | Acrylic, Plexiglas, Glass, Polycarbonate |
| Compressed cardboard or cardstock | Sheet | Light | Yes | Yes | No | High | Tag board, Poster board |
| Corrugated cardboard | Sheet | Light | Yes | Yes | No | High | Cardboard, Corrugated fiberboard |
| Corrugated plastic | Sheet | Light | Yes | Yes | No | Medium | Coroplast, Correx, Corflute, Polypropylene |
| Foam board | Sheet | Light | Yes | Yes | No | High | Fome Core, Mighty Core |
| Foam PVC | Sheet | Light | Yes | Yes | No | Medium | Sintra, Komatex, Celtec, Forex |

Table B-2 Predefined substrate settings (continued)

| Substrate type | Feed method | Weight | Detectable by printer | Use rollers | Conductivity | Vacuum fan level | Examples |
|------------------------|-------------|--------|-----------------------|-------------|--------------|------------------|------------------------|
| Magnetic | Sheet | Light | Yes | Yes | Yes | Medium | Promag |
| Plywood | Sheet | Heavy | Yes | Yes | No | Off | MDO, MDF |
| Polystyrene | Sheet | Light | Yes | Yes | No | Medium | Styrene |
| Polystyrene foam board | Sheet | Light | Yes | Yes | No | Medium | Gatorplast, Ultraboard |

Acrylic sheet (PMMA)

Brand name examples: Plexiglas, Acrylite, Optix, Crylon, Crylux, Perspex, Lucite, Marcryl, Altuglas

- Ensure that the sheet is flat. Sheets that are deformed along either axis (left to right, or front to back) can cause the printhead to strike the substrate.
- Peel the protective film off one side, leaving the other side protected until finishing or installation of the finished graphic.
- Wipe the printing surface with an anti-static tack cloth to remove static charge and any dust or debris.
- If an anti-static tack cloth is not available, a general-purpose industrial cleaner (such as Simple Green) on a lint-free cloth can be used to remove dust or debris. Allow the sheet to sit out on the input table for about 5 minutes to allow the cleaner to evaporate and the static to dissipate.
- Use clean cotton gloves to avoid fingerprints.
- Handle samples with care. Scratches on the substrate before printing will be visible after printing.
- Cast acrylic substrates may require extra care when printing, because of the way they are made. When loading a sheet, pay attention to thickness differences within the same sheet, which may be up to $\pm 10\%$. HP recommends measuring the thickness at different points and manually entering the highest measured thickness value.
- These materials are heavy in large sizes. Do not exceed 60 kg (132 lb) sheets.
- Check at <https://www.printos.com/ml/#/homeMediaLocator> whether the substrate preset for your specific substrate is available. If it is, download and install it in your printer and RIP.
- If there is no specific substrate preset for your substrate, use an available generic preset. For frontlit applications, load the substrate as **Generic Solid Plastic**. For backlit applications, load the substrate as **Generic Backlit Solid Plastic**.
- Both frontlit and backlit acrylics have generic underflood, overflow, and spot print modes available for white printing.

 **IMPORTANT:** HP recommends using Sensitive Mode when the substrate is less than 3 mm (0.1 in) thick. See [Use Sensitive Mode with heat-sensitive substrates on page 234](#).

 **NOTE:** Not all print modes may be available at the printer's introduction date.

- To print color images that do not require white ink, select the **Indoor signage** print mode for applications that will be viewed from short distances. For increased saturation, use **High quality**.

Table B-3 Color-only print modes (no white)

| Generic presets | Fast | Outdoor signage | Indoor signage | High quality | Heat-sensitive |
|-------------------------------|------|-----------------|----------------|--------------|----------------|
| Generic Solid Plastic | N/A | N/A | 6p-100% | 12p-120% | 12p-110% |
| Generic Backlit Solid Plastic | N/A | N/A | N/A | 14p-200% | 18p-180% |

- To print images that require white ink, the following print modes are available:
 - Overflood:** Use this white mode in applications that are printed on the second surface and are viewed through the substrate. In this mode a color layer is printed first and, afterwards, a white ink layer is printed on top. This mode is generally used on clear substrates and requires flipping the image in the RIP or image-editing software.
 - Underflood:** Use this white mode in applications that use colored substrates and require realistic colors. In this mode, a white ink layer is printed first and then a color layer is put on top of it.
 - Spot:** This mode is normally used on both transparent and colored substrates when white ink is not mixed with other colors in the same area.
 - Sandwich:** A white layer is embedded between two different images, allowing a different image to be seen on each side of the shape.

All the generic white print modes use the same amount of colored ink. The white print modes **W100**, **W160**, and **W260** differ only in the amount of white ink used.

Select **White OF W100** when white opacity requirements are normal. For increased white opacity, select **White OF W160**. For maximum white opacity, select **White OF W260**.

Table B-4 Color + white print modes

| Generic presets | Underflood white modes | | | Overflood white modes | | | | Spot white modes | | |
|-------------------------------|------------------------|---------------|---------------|-----------------------|------------------------------|---------------|---------------|------------------|---------------|---------------|
| | White UF W100 | White UF W160 | White UF W260 | White OF W100 | White OF W100 heat-sensitive | White OF W160 | White OF W260 | White SP W100 | White SP W160 | White SP W260 |
| Generic Solid Plastic | N/A | N/A | 33p-120% | 16p-120% | 24p-110% | 24p-120% | N/A | N/A | 11p-110% | 18p-120% |
| Generic Backlit Solid Plastic | N/A | N/A | N/A | 26p-200% | N/A | N/A | N/A | N/A | N/A | N/A |

- Use caution when loading or lifting sheets off the table, as the substrate and ink can be easily scratched.
- When stacking samples, HP recommends placing some material between the acrylic sheets to protect them against scratching.
- Use clean cotton gloves to avoid fingerprints.

- HP particularly recommends using gloves when handling freshly-printed sheets, as they will be hot (though not hot enough to burn your hands).
- Extruded acrylic sheets that are thin and wide have a tendency to deform, and have a high risk of causing printhead crashes. Use sheets with a maximum width of 1.5 m (59 in) when printing on extruded acrylic substrates up to 3 mm (0.12 in) in thickness.

Possible solutions: Pre-cut samples at 1.5 m (59 in), use cast acrylic or polycarbonate sheets instead of extruded ones when printing on thin sheets, or use thicker sheets: 5 mm (0.20 in).

Aluminum composite panel (ACP)

Brand name examples: Alumacore, Alupalite, Dibond, Graphic-AL, Omega-Bond

- Peel the protective film off one side, leaving the other side protected until finishing or installation of the finished graphic.
- Wipe the printing surface with an anti-static tack cloth to remove static charge and any dust or debris.
- If an anti-static tack cloth is not available, a general-purpose industrial cleaner (such as Simple Green) on a lint-free cloth can be used to remove dust or debris. Allow the sheet to sit out on the input table for about 5 minutes to allow the cleaner to evaporate and the static to dissipate.
- Ensure that the substrate is flat and there are no damaged corners, edges, or ends. If the edges are bent, they should be flattened before printing. A head height greater than the standard 1.8 mm (0.07 in) may be necessary to avoid damaged or bowed edges that will interfere with the path of the carriage.
- Use clean cotton gloves to avoid fingerprints and avoid the risk of cutting yourself with the edges of the sheet.
- Handle samples with care. Scratches on the substrate before printing will be visible after printing.
- Check at <https://www.printos.com/ml/#/homeMediaLocator> whether the substrate preset for your specific substrate is available. If it is, download and install it in your printer and RIP.
- If there is no specific substrate preset for your substrate, use the **Generic Aluminium Composite Panel** preset.
- Aluminium composite panels have generic underflood and spot print modes available for white printing.

 **NOTE:** Not all print modes may be available at the printer's introduction date.

- To print color images that do not require white ink, select the **Indoor signage** print mode for applications that will be viewed from short distances. For increased saturation, use **High quality**.

Table B-5 Color-only print modes (no white)

| Generic presets | Fast | Outdoor signage | Indoor signage | High quality |
|-----------------------------------|------|-----------------|----------------|--------------|
| Generic Aluminium Composite Panel | N/A | N/A | 6p-100% | 12p-120% |

- To print images that require white ink, the following print modes are available:

- **Underflood:** Use this white mode on substrates such as brushed or colored aluminium when you need realistic colors. In this mode, a white ink layer is printed first and then a color layer is put on top of it.
- **Spot:** This mode is normally used on substrates such as brushed or colored aluminium when white ink is not mixed with other colors in the same area.

Table B-6 Color + white print modes

| Generic presets | Underflood white modes | | | Overflood white modes | | | Spot white modes | | |
|-----------------------------------|------------------------|---------------|---------------|-----------------------|---------------|---------------|------------------|---------------|---------------|
| | White UF W100 | White UF W160 | White UF W260 | White OF W100 | White OF W160 | White OF W260 | White SP W100 | White SP W160 | White SP W260 |
| Generic Aluminium Composite Panel | N/A | N/A | 33p-120 % | N/A | N/A | N/A | N/A | N/A | 18p-120 % |

- Use caution when loading or lifting sheets off the table, as the substrate and ink can be easily scratched.
- HP recommends using gloves when handling freshly-printed sheets, as they will be hot (though not hot enough to burn your hands).

Compressed cardboard or cardstock

Also known as cover stock, paperboard, pasteboard, and tag board

- Store substrates flat, in a clean environment with the same or similar temperature and humidity as in the printer room. Changes in temperature or humidity will cause the material to warp and may cause printhead crashes.
- Some coated sheets may interact with the ink, yielding poor print quality. Test coated materials for compatibility before purchasing significant quantities.
- Clean with a lint-free cloth to remove any dust and debris.
- Use gloves when handling the substrate to avoid transferring fingerprints and oils to the print surface.
- The substrate can bend and crease easily. Watch for edges that may strike the carriage.
- Check at <https://www.printos.com/ml/#/homeMediaLocator> whether the substrate preset for your specific substrate is available. If it is, download and install it in your printer and RIP.
- If there is no specific substrate preset for your substrate, use the **Generic Compressed Cardboard** preset.
- Some cardboard substrates, especially uncoated ones, are porous and may absorb the ink, giving a washed-out appearance. Use the [Add a substrate preset on page 81](#) process to increase the amount of ink or to create an underflood white printmode to boost colour saturation.

 **NOTE:** Not all print modes may be available at the printer's introduction date.

- To print color images that do not require white ink, select the **Outdoor signage** print mode for applications that will be viewed from medium to long distances. For increased saturation, use **Indoor signage** or **High quality**.

Table B-7 Color-only print modes (no white)

| Generic presets | Fast | Outdoor signage | Indoor signage | High quality |
|------------------------------|------|-----------------|----------------|--------------|
| Generic Compressed Cardboard | N/A | 4p-80% | 6p-100% | 8p-110% |

- There are no white generic presets for compressed cardboards. If white ink is needed (for colored or uncoated cardboards), see [Add a substrate preset on page 81](#).
- Use gloves to avoid transferring fingerprints and oils to the print surface.
- In some cases, particularly thin samples—thinner than 1.5 mm (0.06 in)—may warp during the printing process. Allow samples to rest for 10-15 min after printing to recover their initial shape.

Corrugated cardboard

Also known as corrugated fiberboard and box board

- Store substrates flat, in a clean environment with the same or similar temperature and humidity as in the printer room. Recommended storage conditions: 19-23°C (66-73°F), 55-65% RH. Changes in temperature or humidity will cause the material to warp.
- After taking boards from the pallet, cover the pallet with its original packaging and, if possible, strap it again.
- The substrate can bend and crease easily. Watch for edges that may strike the carriage.
- Concave bent boards are much preferable to convex ones. Ordering boards with the same liner on both sides allows you to choose the side that is more suitable for holding.
- For some very bent samples, tape and edge holders may be needed.
- Check at <https://www.printos.com/ml/#/homeMediaLocator> whether the substrate preset for your specific substrate is available. If it is, download and install it in your printer and RIP.
- If there is no specific substrate preset for your substrate, use the **Generic Corrugated Cardboard** preset.
- Cardboard substrates, especially uncoated ones, are porous and may absorb the ink, giving a washed-out appearance. Use the [Add a substrate preset on page 81](#) process to increase the amount of ink or to create an underflood white printmode to boost colour saturation.

 **NOTE:** Not all print modes may be available at the printer's introduction date.

- To print color images that do not require white ink, select the **Outdoor signage** print mode for applications that will be viewed from a distance of at least 3 m (10 ft). For increased saturation, use **Indoor signage** or **High quality**.

Table B-8 Color-only print modes (no white)

| Generic presets | Fast | Outdoor signage | Indoor signage | High quality |
|------------------------------|------|-----------------|----------------|--------------|
| Generic Corrugated Cardboard | N/A | 4p-80% | 6p-100% | 8p-110% |

- There are no white generic presets for corrugated cardboards. If white ink is needed (for colored or uncoated cardboards), see [Add a substrate preset on page 81](#).

- In some cases, samples may warp during the printing process. Allow samples to rest for 10-15 min after printing to recover their initial shape.
- Very bent samples may not be printable.

Foam board

Brand name examples: Fome-Cor, Kapa, Gator, MightyCore, Airplac, Gatorplast, Kapa plast, Ultraboard, Infinity

- Store substrates flat, in a clean environment with the same or similar temperature and humidity as in the printer room. Changes in temperature or humidity will cause the substrate to warp.
- Foam boards with plastic liners tend to hold static charge. Avoid sliding the substrate from the stack or carrying it across carpeted surfaces. Ensure that substrate tables are attached and secured to the printer to provide a grounding path for static-loaded substrate.
- For plastic liner foam boards, if an anti-static tack cloth is not available, a general-purpose industrial cleaner (such as Simple Green) on a lint-free cloth can be used to remove dust or debris. Allow the sheet to sit out on the input table for about 5 minutes to allow the cleaner to evaporate and the static to dissipate.
- The substrate is susceptible to dents and damage. Watch for corners and edges that may strike the carriage.
- Check at <https://www.printos.com/ml/#/homeMediaLocator> whether the substrate preset for your specific substrate is available. If it is, download and install it in your printer and RIP.
- If there is no specific substrate preset for your substrate, use the **Generic Paper Foamboard** preset for substrates with a cellulosic liner, or the **Generic Plastic Foamboard** preset for substrates with a plastic liner.
- These substrates are heat-sensitive, and HP does not recommend exceeding a 70°C inline measure markup needed (158°F) curing temperature to avoid deformations, liner delamination, and substrate thickness increase.



NOTE: Not all print modes may be available at the printer's introduction date.

- To print color images that do not require white ink, select the **Outdoor signage** print mode for applications that will be viewed from a distance of at least 3 m (10 ft) and do not need saturated colors. For increased color saturation, use **Indoor signage** or **High quality**.

Table B-9 Color-only print modes (no white)

| Generic presets | Fast | Outdoor signage | Indoor signage | High quality |
|--------------------|------|-----------------|----------------|--------------|
| Generic Foam Board | N/A | 4p-80% | 6p-100% | 8p-110% |

- There are no white generic presets for foam boards. If white ink is needed (for colored boards), see [Add a substrate preset on page 81](#).
- You can usually recover from heat warp by laying the substrate flat and allowing it to cool.
- Always use a very sharp blade when trimming.

- The substrate is susceptible to dents, and it damages more easily than most other substrate types. Handle samples with care.
- Substrates with paper liner have a delicate surface that may show gloss changes if they are slid from the stack. Handle paper-liner substrates with special care.

Foam PVC

Also known as closed-cell PVC foamboard

Brand name examples: Celtec, Forex, Komatex, Sintra, Palight, Trovicel

- If the substrate has a protective film attached, peel off the protective film from one side, leaving the other side protected until finishing or installation of the finished graphic.
- Wipe the printing surface with an anti-static tack cloth to remove static charge and any dust or debris.
- If an anti-static tack cloth is not available, a general-purpose industrial cleaner (such as Simple Green) on a lint-free cloth can be used to remove dust or debris. Allow the sheet to sit out on the input table for about 5 minutes to allow the cleaner to evaporate and the static to dissipate.
- Some foams may have a smooth and soft surface that can be easily scratched or damaged. Handle substrates with care.
- Check at <https://www.printos.com/ml/#/homeMediaLocator> whether the substrate preset for your specific substrate is available. If it is, download and install it in your printer and RIP.
- If there is no specific substrate preset for your substrate, use the **Generic PVC Foam** preset.



NOTE: Not all print modes may be available at the printer's introduction date.

- To print color images that do not require white ink, select the **Fast** print mode for applications that will be viewed from a distance of at least 3 m (10 ft). For increased color saturation, use **Outdoor signage** or **Indoor signage**.

Table B-10 Color-only print modes (no white)

| Generic presets | Fast | Outdoor signage | Indoor signage | High quality |
|------------------|--------|-----------------|----------------|--------------|
| Generic PVC Foam | 3p-70% | 4p-90% | 6p-110% | N/A |

- To print images that require white ink, the following print modes are available:
 - **Underflood:** Use this white mode on colored foam when you need realistic colors. In this mode, a white ink layer is printed first and then a color layer is put on top of it.
 - **Spot:** This mode is used on colored foam substrates when white ink is not mixed with other colors in the same area.

Table B-11 Color + white print modes

| Generic presets | Underflood white modes | | | Overflood white modes | | | Spot white modes | | |
|------------------|------------------------|---------------|---------------|-----------------------|---------------|---------------|------------------|---------------|---------------|
| | White UF W100 | White UF W160 | White UF W260 | White OF W100 | White OF W160 | White OF W260 | White SP W100 | White SP W160 | White SP W260 |
| Generic PVC Foam | N/A | N/A | 33p-120 % | N/A | N/A | N/A | N/A | N/A | 18p-120 % |

Substrates thinner than 2.5 mm may show a higher tendency to deform than thicker substrates. For thin substrates, HP recommends using the available heat-sensitive print modes. Heat-sensitive print modes provide a smoother temperature ramp that improves sheet flatness. Inline measure markup needed

Table B-12 Color + white heat-sensitive print modes

| Generic presets | Fast heat-sensitive | Heat-sensitive | Heat-sensitive with white |
|------------------|---------------------|----------------|---------------------------|
| Generic PVC Foam | 8p-80% | 12p-110% | |

- No special handling required.
- If ink adhesion is inadequate, wait 24 hours before finishing.
- Always use a sharp blade when cutting.

Glass and ceramics

This topic explains the concepts involved in this subject.

- The smooth, non-porous surface of glass does not provide a good interface for ink to adhere, making it susceptible to scratches and scraping. Special precautions are necessary in the handling and display of the printed piece to protect it from abrasion.
- Adhesion can be improved with the use of a pre-treatment or primer.
- Use a lint-free cloth with a glass cleaner to remove dust or debris. Do not use a detergent.
- Use clean cotton gloves to avoid fingerprints.
- If a pre-treatment primer is used, apply it according to the instructions and allow it to dry before printing.
- Select **Clear Sheet** when configuring and loading these substrates.
- Substrate placement detection is disabled when using these substrates. When loading, it is necessary to enter the location of the left (user side) and right (service side) edges of the substrate according to the **Substrate measurement option**.
- Use a Clear Sheet substrate preset from the RIP software.
- For applications that require fine detail, use the **Fine text** option and/or lower the printhead height from its nominal 2.2 mm (0.085 in) setting.
- Use clean cotton gloves to avoid fingerprints.

- Take care when loading or lifting sheets off the table, as substrate and ink can easily be scratched.
- Use protective gloves to avoid the risk of burning your hands.
- Depending on the end use application, some treatment after printing may be necessary to minimize the risk of surface damage.

Wood

Examples: Raw, primed or painted wood, MDO, MDF

- Store substrates flat, in a clean environment with the same or similar temperature and humidity as in the printer room. Changes in temperature or humidity will cause the substrate to warp.
- Substrates are often supplied non-rectangular, so trimming them to rectangular may be necessary for some applications, such as edge-to-edge printing. Make sure all edges are cut clean and are free from burrs and/or excess substrate.
- Use compressed air to blow dust and debris from the printing surface.
- Depending on application, ink coverage, image content, and wood surface, all print modes may print acceptably.
- Select **Wood** when configuring and loading these substrates.
- Some surfaces are more porous and absorb the ink, giving a washed-out appearance. Use the RIP software's **Saturated rendering intent** option to increase saturation.
- Non-white substrates may not be detected by the onboard camera. If so, create a copy of the **Wood** substrate using the Substrate Wizard, and change the **Detectable by printer** option to **No**.
- Due to the strength and shape memory of wood products, the printer may not be able to feed some warped sheets.
- A head height greater than the normal 2.2 mm (0.085 in) setting may be necessary to avoid the carriage scraping on non-flat materials.
- Use a Wood substrate preset from the RIP software.
- These substrates are heavy in large sizes. Do not exceed 68 kg (150 lb).

Polycarbonate sheet

Brand name examples: Lexan, Makrolon, Tuffak

- In general, ink adhesion is better on polycarbonate than on acrylic or glass.
- However, the smooth, non-porous surface makes it susceptible to scratches and scraping. Special precautions are necessary in the handling and display of the printed piece to protect it from abrasion.
- Peel off the protective film from one side, leaving the other side protected until finishing or installation of the finished graphic.
- This material tends to hold static charge. Follow the advice in [Static electricity on page 75](#).

- Ensure that substrate tables are attached and secured to the printer to provide a grounding path for static-loaded substrate.
- Wipe the printing surface with an anti-static tack cloth to remove static charge and any dust or debris.
- If an anti-static tack cloth is not available, a general-purpose industrial cleaner (such as Simple Green) on a lint-free cloth can be used to remove dust or debris. Allow the sheet to sit out on the input table for about 5 minutes to allow the cleaner to evaporate and the static to dissipate.
- Depending on the end-use application, ink adhesion may be an issue. Use of a polycarbonate primer can improve ink adhesion.
- Select **Clear Sheet** when configuring and loading these substrates.
- Substrate placement detection is disabled when using these substrates. When loading, it is necessary to enter the location of the left (user side) and right (service side) edges of the substrate according to the **Substrate measurement option**.
- Use a Clear Sheet substrate preset from the RIP software.
- Use clean cotton gloves to avoid fingerprints.
- Take care when loading or lifting sheets off the table, as substrate and ink can be easily scratched.
- Depending on the end use application, some treatment after printing may be necessary to minimize the risk of surface damage.

Polystyrene sheet

Examples: High-impact polystyrene sheet, HIPS

- This substrate tends to hold static charge. Avoid sliding it from the stack or carrying it across carpeted surfaces.
- Follow the advice in [Static electricity on page 75](#).
- Ensure that substrate tables are attached and secured to the printer to provide a grounding path for static-loaded substrate.
- Wipe the printing surface with an anti-static tack cloth to remove static charge and any dust or debris.
- If an anti-static tack cloth is not available, a general-purpose industrial cleaner (such as Simple Green) on a lint-free cloth can be used to remove dust or debris. Allow the sheet to sit out on the input table for about 5 minutes to allow the cleaner to evaporate and the static to dissipate.
- Select **Polystyrene** when configuring and loading these substrates.
- These substrates are heat-sensitive, specifically thinner sheets: less than 0.4 mm (0.015 in). They may require a higher vacuum setting, faster print modes, greater than standard head height, and printing delays in some combination to achieve best output.
- Use a Polystyrene substrate preset from the RIP software.
- If ink adhesion is inadequate, print in a higher-quality mode and/or wait 24 hours before finishing.
- Always use a sharp blade when cutting.

Polypropylene sheet

Brand name examples: Akyplen, Polygraph.ics.P

- In general, ink adhesion is better on polycarbonate than on acrylic or glass.
- However, the smooth, non-porous surface makes it susceptible to scratches and scraping. Special precautions are necessary in the handling and display of the printed piece to protect it from abrasion.
- Peel off the protective film from one side, leaving the other side protected until finishing or installation of the finished graphic.
- This material tends to hold static charge. Follow the advice in [Static electricity on page 75](#).
- Ensure that substrate tables are attached and secured to the printer to provide a grounding path for static-loaded substrate.
- Wipe the printing surface with an anti-static tack cloth to remove static charge and any dust or debris.
- If an anti-static tack cloth is not available, a general-purpose industrial cleaner (such as Simple Green) on a lint-free cloth can be used to remove dust or debris. Allow the sheet to sit out on the input table for about 5 minutes to allow the cleaner to evaporate and the static to dissipate.
- Depending on the end-use application, ink adhesion may be an issue. Use of a polycarbonate primer can improve ink adhesion.
- Select **Clear Sheet** when configuring and loading these substrates.
- Substrate placement detection is disabled when using these substrates. When loading, it is necessary to enter the location of the left (user side) and right (service side) edges of the substrate according to the **Substrate measurement option**.
- Use a Clear Sheet substrate preset from the RIP software.
- Use clean cotton gloves to avoid fingerprints.
- Take care when loading or lifting sheets off the table, as substrate and ink can be easily scratched.
- Depending on the end use application, some treatment after printing may be necessary to minimize the risk of surface damage.

PVC rigid sheet (U-PVC)

Brand name examples: Akyplen, Polygraph.ics.P

- In general, ink adhesion is better on polycarbonate than on acrylic or glass.
- However, the smooth, non-porous surface makes it susceptible to scratches and scraping. Special precautions are necessary in the handling and display of the printed piece to protect it from abrasion.
- Peel off the protective film from one side, leaving the other side protected until finishing or installation of the finished graphic.
- This material tends to hold static charge. Follow the advice in [Static electricity on page 75](#).

- Ensure that substrate tables are attached and secured to the printer to provide a grounding path for static-loaded substrate.
- Wipe the printing surface with an anti-static tack cloth to remove static charge and any dust or debris.
- If an anti-static tack cloth is not available, a general-purpose industrial cleaner (such as Simple Green) on a lint-free cloth can be used to remove dust or debris. Allow the sheet to sit out on the input table for about 5 minutes to allow the cleaner to evaporate and the static to dissipate.
- Depending on the end-use application, ink adhesion may be an issue. Use of a polycarbonate primer can improve ink adhesion.
- Select **Clear Sheet** when configuring and loading these substrates.
- Substrate placement detection is disabled when using these substrates. When loading, it is necessary to enter the location of the left (user side) and right (service side) edges of the substrate according to the **Substrate measurement option**.
- Use a Clear Sheet substrate preset from the RIP software.
- Use clean cotton gloves to avoid fingerprints.
- Take care when loading or lifting sheets off the table, as substrate and ink can be easily scratched.
- Depending on the end use application, some treatment after printing may be necessary to minimize the risk of surface damage.

PET (A-PET, PET-G) rigid sheet

Brand name examples: Lumex, Vivak

- In general, ink adhesion is better on polycarbonate than on acrylic or glass.
- However, the smooth, non-porous surface makes it susceptible to scratches and scraping. Special precautions are necessary in the handling and display of the printed piece to protect it from abrasion.
- Peel off the protective film from one side, leaving the other side protected until finishing or installation of the finished graphic.
- This material tends to hold static charge. Follow the advice in [Static electricity on page 75](#).
- Ensure that substrate tables are attached and secured to the printer to provide a grounding path for static-loaded substrate.
- Wipe the printing surface with an anti-static tack cloth to remove static charge and any dust or debris.
- If an anti-static tack cloth is not available, a general-purpose industrial cleaner (such as Simple Green) on a lint-free cloth can be used to remove dust or debris. Allow the sheet to sit out on the input table for about 5 minutes to allow the cleaner to evaporate and the static to dissipate.
- Depending on the end-use application, ink adhesion may be an issue. Use of a polycarbonate primer can improve ink adhesion.
- Select **Clear Sheet** when configuring and loading these substrates.

- Substrate placement detection is disabled when using these substrates. When loading, it is necessary to enter the location of the left (user side) and right (service side) edges of the substrate according to the **Substrate measurement option**.
- Use a Clear Sheet substrate preset from the RIP software.
- Use clean cotton gloves to avoid fingerprints.
- Take care when loading or lifting sheets off the table, as substrate and ink can be easily scratched.
- Depending on the end use application, some treatment after printing may be necessary to minimize the risk of surface damage.

PE (LDPE, HDPE) rigid sheet

This topic explains the concepts involved in this subject.

- In general, ink adhesion is better on polycarbonate than on acrylic or glass.
- However, the smooth, non-porous surface makes it susceptible to scratches and scraping. Special precautions are necessary in the handling and display of the printed piece to protect it from abrasion.
- Peel off the protective film from one side, leaving the other side protected until finishing or installation of the finished graphic.
- This material tends to hold static charge. Follow the advice in [Static electricity on page 75](#).
- Ensure that substrate tables are attached and secured to the printer to provide a grounding path for static-loaded substrate.
- Wipe the printing surface with an anti-static tack cloth to remove static charge and any dust or debris.
- If an anti-static tack cloth is not available, a general-purpose industrial cleaner (such as Simple Green) on a lint-free cloth can be used to remove dust or debris. Allow the sheet to sit out on the input table for about 5 minutes to allow the cleaner to evaporate and the static to dissipate.
- Depending on the end-use application, ink adhesion may be an issue. Use of a polycarbonate primer can improve ink adhesion.
- Select **Clear Sheet** when configuring and loading these substrates.
- Substrate placement detection is disabled when using these substrates. When loading, it is necessary to enter the location of the left (user side) and right (service side) edges of the substrate according to the **Substrate measurement option**.
- Use a Clear Sheet substrate preset from the RIP software.
- Use clean cotton gloves to avoid fingerprints.
- Take care when loading or lifting sheets off the table, as substrate and ink can be easily scratched.
- Depending on the end use application, some treatment after printing may be necessary to minimize the risk of surface damage.

Honeycomb panels

This topic explains the concepts involved in this subject.

- In general, ink adhesion is better on polycarbonate than on acrylic or glass.
- However, the smooth, non-porous surface makes it susceptible to scratches and scraping. Special precautions are necessary in the handling and display of the printed piece to protect it from abrasion.
- Peel off the protective film from one side, leaving the other side protected until finishing or installation of the finished graphic.
- This material tends to hold static charge. Follow the advice in [Static electricity on page 75](#).
- Ensure that substrate tables are attached and secured to the printer to provide a grounding path for static-loaded substrate.
- Wipe the printing surface with an anti-static tack cloth to remove static charge and any dust or debris.
- If an anti-static tack cloth is not available, a general-purpose industrial cleaner (such as Simple Green) on a lint-free cloth can be used to remove dust or debris. Allow the sheet to sit out on the input table for about 5 minutes to allow the cleaner to evaporate and the static to dissipate.
- Depending on the end-use application, ink adhesion may be an issue. Use of a polycarbonate primer can improve ink adhesion.
- Select **Clear Sheet** when configuring and loading these substrates.
- Substrate placement detection is disabled when using these substrates. When loading, it is necessary to enter the location of the left (user side) and right (service side) edges of the substrate according to the **Substrate measurement option**.
- Use a Clear Sheet substrate preset from the RIP software.
- Use clean cotton gloves to avoid fingerprints.
- Take care when loading or lifting sheets off the table, as substrate and ink can be easily scratched.
- Depending on the end use application, some treatment after printing may be necessary to minimize the risk of surface damage.

Metal panels

This topic explains the concepts involved in this subject.

- In general, ink adhesion is better on polycarbonate than on acrylic or glass.
- However, the smooth, non-porous surface makes it susceptible to scratches and scraping. Special precautions are necessary in the handling and display of the printed piece to protect it from abrasion.
- Peel off the protective film from one side, leaving the other side protected until finishing or installation of the finished graphic.
- This material tends to hold static charge. Follow the advice in [Static electricity on page 75](#).

- Ensure that substrate tables are attached and secured to the printer to provide a grounding path for static-loaded substrate.
- Wipe the printing surface with an anti-static tack cloth to remove static charge and any dust or debris.
- If an anti-static tack cloth is not available, a general-purpose industrial cleaner (such as Simple Green) on a lint-free cloth can be used to remove dust or debris. Allow the sheet to sit out on the input table for about 5 minutes to allow the cleaner to evaporate and the static to dissipate.
- Depending on the end-use application, ink adhesion may be an issue. Use of a polycarbonate primer can improve ink adhesion.
- Select **Clear Sheet** when configuring and loading these substrates.
- Substrate placement detection is disabled when using these substrates. When loading, it is necessary to enter the location of the left (user side) and right (service side) edges of the substrate according to the **Substrate measurement option**.
- Use a Clear Sheet substrate preset from the RIP software.
- Use clean cotton gloves to avoid fingerprints.
- Take care when loading or lifting sheets off the table, as substrate and ink can be easily scratched.
- Depending on the end use application, some treatment after printing may be necessary to minimize the risk of surface damage.

C Flexible substrate recommendations

The flexible substrate types described in this appendix are compatible with your printer, if the roll-to-roll upgrade kit has been installed and enabled.

 **NOTE:** HP recommends the use of the hold-down plate for better control of the substrate during printing. See [Hold-down plate on page 65](#).

Predefined substrate settings

This topic provides a full set of reference information for this subject.

Table C-1 Predefined substrate settings

| Substrate type | Feed method | Weight | Detectable by printer | Use rollers | Conductivity | Vacuum fan level | Examples |
|---------------------------|-------------|--------|-----------------------|-------------|--------------|------------------|------------------------------------------|
| Backlit banner | Roll | - | No | Yes | No | Medium | Translucent backlit film, Backlit banner |
| Frontlit banner | Roll | - | Yes | Yes | No | Medium | Scrim banner vinyl, PVC flex film |
| Canvas | Roll | - | Yes | Yes | No | Medium | HP Satin Canvas |
| Clear film | Roll | - | No | Yes | No | Medium | Polyester film, Cling vinyl |
| Photobase | Roll | - | Yes | Yes | No | Medium | HP UV Premium Photobase Paper |
| Self-adhesive vinyl (SAV) | Roll | - | Yes | Yes | No | Medium | Calendered vinyl, Cast vinyl |
| Textile | Roll | - | Yes | Yes | No | Medium | HP Heavy Textile Banner |

 **NOTE:** To print in Sensitive Mode, enable the curing lever. When you have finished printing in Sensitive Mode, disable the curing lever.

Self-adhesive vinyls

This topic explains the concepts involved in this subject.

Applications

- Retail decoration
- Window graphics

Media characteristics

- Typically made from polyvinyl chloride (PVC), known for its durability and flexibility.

- Available in different finishes, such as gloss, matte, and satin.
- The back of the vinyl sheet is coated with a pressure-sensitive adhesive that allows it to stick to surfaces without the need for additional glue. The adhesive can be permanent or removable, depending on the intended use.
- A protective paper or film backing covers the adhesive layer. This backing is peeled away before application.

Media types

- Monomeric: Short term, economic. Indicated for retail, window graphics, labels, and sticker applications.
- Polymeric: Intermediate performance and price. Indicated for general applications.
- Cast: Durable, conformable, high cost. Indicated for car and 3D shape wrapping.
- Perforated or one-way vision: From the outside, viewers see the printed graphic, while from the inside, the perforated holes allow visibility and light penetration. Indicated for vehicle wraps (bus, train) and window graphics.

Sustainable choice

Traditional self-adhesive vinyl is primarily made from polyvinyl chloride (PVC), a type of plastic derived from petroleum. PVC production involves environmental concerns, including the release of harmful chemicals during manufacturing.

Manufacturers are developing PVC-free options, using alternative materials such as polypropylene (PP) and polyethylene (PE). These materials can be more environmentally friendly, producing fewer emissions and being easier to recycle.

Printing recommendations/challenges

- In general, it is easy to achieve good print quality and substrate stability using generic profiles.
- Always turn off overcoat when laminating.
- Banding in some area fills with difficult colors: increase the number of passes.
- Some transparent materials with soft and thin films and clear film might present wrinkles and belt marks during printing due to thermal impact. Decreasing curing temperature and vacuum and adding interswath delays to ensure proper curing will help.

Banners

This topic explains the concepts involved in this subject.

Applications

- Indoor and outdoor advertising

Media characteristics

- Banners are large, flexible signs used for promotional or advertising purposes.
- Designed to be easily displayed in various environments, both indoors and outdoors.
- Composed of a sandwich of structural support (mesh or scrim) and a printable material.

- The most common material is PVC. It is especially popular for its durability and resistance to weather. However, alternative polymers or fabrics with better environmental properties are also available for the same applications.

Media types

- Frontlit: For front-illuminated applications, either indoor (e.g., roll-ups) or outdoor.
- Double-sided: Blackout opacity.
- Mesh: Allows vision through the unprinted side. Reduced weight. Ideal for windy outdoor conditions.
- Tyvek: Look and feel like paper. Recyclable.
- Backlit: For back-illuminated applications.

Sustainable choice

Traditional banners are primarily made from polyvinyl chloride (PVC), a type of plastic derived from petroleum. PVC production involves environmental concerns, including the release of harmful chemicals during manufacturing.

Manufacturers are developing PVC-free options, using alternative materials such as polypropylene (PP) and polyethylene (PE). These materials can be more environmentally friendly, producing fewer emissions and being easier to recycle.

Printing recommendations/challenges

- These materials are sensitive to temperature. Excessive heat can cause deformation, leading to wrinkles and warping.
- Plasticizers are added to increase flexibility, softness, and workability. Without plasticizers, PVC is naturally rigid and brittle. These components might migrate to the surface of the banner, causing IQ artifacts.
- Plasticizers might also interact with latex ink, causing ink transfer to the back side of the material depending on environmental conditions (humidity, temperature, pressure).

Paper

This topic explains the concepts involved in this subject.

Applications

- Posters
- Outdoor billboards

Media characteristics

- Composed of a base of natural fibers (wood or non-wood).
- Paper can be coated or uncoated.
- Coatings (a compound of mineral pigments and binders applied on top of the fiber-based layer) improve print quality and other attributes.
- Depending on the application, papers can contain several layers designed to achieve best-in-class performance (e.g., water resistance).

Media types

- Blueback Paper: Opaque paper with a blue backing that prevents light or previous images from showing through when pasted. Inexpensive and water-resistant, with a matte finish.
- Poster Paper: Lightweight, affordable paper used for indoor signage like posters, advertisements, and point-of-sale displays. Available in glossy or matte finishes. Ideal for temporary signage in protected environments.

Sustainable choice

- Natural fiber-based materials like paper are always a better environmental option compared to polymeric substrates.
- Look for FSC, PEFC labels to ensure proper forest management.
- Coated papers are less sustainable compared to uncoated ones. Recyclability will depend on the type of coating used. Choose materials with lightweight coatings and lower additives content.

Printing recommendations/challenges

- Paper might expand when interacting with ink, causing cockle or warping effects.
- To mitigate this issue, try reducing the amount of fluid (ink density, PT, OC) and increase drying AF.
- Humidity changes might have an impact on media control.
- High diversity of papers, coatings, and finishes within this family makes it more challenging to find universal settings.

PVC banners

This topic explains the concepts involved in this subject.

- Peel off the protective film from one side, leaving the other side protected until finishing or installation of the finished graphic.
- Wipe the printing surface with an anti-static tack cloth to remove static charge and any dust or debris.
- If an anti-static tack cloth is not available, a general-purpose industrial cleaner (such as Simple Green) on a lint-free cloth can be used to remove dust or debris. Allow the sheet to sit out on the input table for about 5 minutes to allow the cleaner to evaporate and the static to dissipate.
- Ensure that the substrate is flat and that there are no damaged corners, edges, or ends.
- Take care when loading or lifting sheets off the table, as substrate and ink can be easily scratched.
- Use protective gloves to avoid the risk of burning your hands.
- Avoid using aluminum composite materials, such as Alucobond, that have a polyvinylidene fluoride (PVDF) surface coating. PVDF coated materials have reduced ink adhesion and may not work for some applications.

Papers

Also known as: cover stock, paperboard, pasteboard, tag board

- Store substrates flat, in a clean environment with the same or similar temperature and humidity as in the printer room. Changes in temperature or humidity will cause the material to warp.
- Some coated sheets may interact with the ink, yielding poor print quality. Test coated materials for compatibility before purchasing significant quantities.
- Clean with a lint-free cloth to remove any dust and debris.
- Use gloves when handling the substrate to avoid transferring fingerprints and oils to the print surface.
- The substrate can bend and crease easily. Watch for edges that may strike the carriage.
- Select **Card Stock** when configuring and loading these substrates.
- Use a Card Stock substrate preset from the RIP software.
- Some materials are more porous and absorb the ink, giving a washed-out appearance. Use the RIP software's **Saturated rendering intent** option to increase saturation.
- Use gloves to avoid transferring fingerprints and oils to the print surface.
- Use caution when lifting it off the table to avoid creases.

Textiles

Also known as: corrugated fiberboard, box board

- Store substrates flat, in a clean environment with the same or similar temperature and humidity as in the printer room. Changes in temperature or humidity will cause the material to warp.
- Clean with a lint-free cloth to remove any dust and debris.
- The substrate can bend and crease easily. Watch for edges that may strike the carriage.
- Depending on application, ink coverage, and image content, all print modes may print acceptably. Faster print modes are less susceptible to bowing of the substrate due to heat.
- Select **Corrugated Cardboard** when configuring and loading these substrates.
- Some colored substrates may not be detectable by the onboard camera. In this case, create a copy of the Card Stock substrate using the Substrate Wizard and change the **Detectable by printer** option to **No**.
- Use the **Warped media** option when loading non-flat substrates. Using this option reduces the available print area.
- Use the lowest possible UV lamp power setting to cure the ink.
- Use a Corrugated Cardboard substrate preset from the RIP software.
- Some materials are more porous and absorb the ink, giving a washed-out appearance. Use the RIP software's **Saturated rendering intent** option to increase saturation.
- Use caution when lifting it off the table to avoid creases.

Flexible films

Also known as: corrugated or fluted polypropylene

- The quality of corrugated polypropylene can vary greatly. A corona treatment is generally applied when manufactured to increase the surface tension for better ink adhesion. This corona treatment will diminish over time. Substrate that has been shipped long distances or stored for an extended period of time will have more problems with ink adhesion.
- This substrate tends to hold static charge. Avoid sliding it from the stack or carrying it across carpeted surfaces.
- Follow the advice in [Static electricity on page 75](#).
- Ensure that substrate tables are attached and secured to the printer to provide a grounding path for static-loaded substrate.
- Substrates are often supplied in non-rectangular form, so trimming them to rectangular may be necessary for some applications, such as edge-to-edge printing. Make sure all edges are cut clean and are free from burrs and/or excess substrate.
- Wipe the printing surface with an anti-static tack cloth to remove static charge and any dust or debris.
- If an anti-static tack cloth is not available, a general-purpose industrial cleaner (such as Simple Green) on a lint-free cloth can be used to remove dust or debris. Allow the sheet to sit out on the input table for about 5 minutes to allow the cleaner to evaporate and the static to dissipate.
- Depending on application, ink coverage, and image content, all print modes may print acceptably.
- Faster print speeds can be obtained without noticeable banding by feeding the substrate with the flutes parallel to the printhead carriage motion.
- Select **Corrugated Plastic** when configuring and loading these substrates.
- Non-white substrates may not be detectable by the onboard camera. In this case, create a copy of the Corrugated Plastic substrate using the Substrate Wizard and change the **Detectable by printer** option to **No**.
- These substrates are heat-sensitive. They may require a higher vacuum setting, faster print modes, greater than standard head height, and printing delays in some combination to achieve best output.
- Use a Corrugated Plastic substrate preset from the RIP software.
- Ink adhesion improves over 24 hours. Sometimes it is beneficial to wait 24 hours before cutting full-bleed prints.

Index

- A**
 - accessories 210
 - acoustic specifications 223
 - add a print job 91
 - alerts
 - errors 23
 - alerts, warnings 23
 - application hangs up 202
- B**
 - beacon 14
 - Belt 50
 - bow deformation 159
- C**
 - carriage view
 - 700 and 800 13
 - caution 7
 - color calibration 127, 128
 - color consistency between printers 130
 - color profiles 130
 - communication problems 200
 - components of printer 10
 - condensation collector 114
 - empty 141
 - replace 141
 - consumables 210
 - control-panel options
 - load 55
 - load roll 55
 - replace large cartridges 95
 - replace maintenance cartridge 105
 - replace printheads 98, 99, 102
 - unload 62
 - unload substrate 62
 - view printer information 2
 - curing modules
 - clean 148
 - curve deformation 159
 - Customer Care 2
 - Customer Self-Repair 203
- D**
 - documentation 1
- E**
 - ecological specifications 223
 - encoder strip
 - clean 139
 - environmental specifications 223
 - extension tables 211
- F**
 - firmware update 23, 150
 - front view 11
 - functional specifications 220
- G**
 - graininess 177
- H**
 - hard disk specification 222
 - HP Customer Care 2
 - HP PrintOS 14
- I**
 - ICC profiles 130
 - ink cartridge
 - specification 220
 - ink cartridge (800 series)
 - cannot insert 194
 - remove 95
 - ink cartridge (R530 series)
 - about 94
 - ink cartridge)
 - insert 96
 - replace 95
 - Ink collection unit 109
 - ink system tips 115
 - Internal Print Server
 - start 21
 - update 23, 150
 - widgets 22
- L**
 - labels, warning 7
 - lateral pinch wheels 215
 - lubrication felt, replace 140
- M**
 - maintenance cartridge
 - cannot insert 196
 - replace 105
 - specification 220
 - maintenance cartridge)
 - about 105
 - maintenance tools 131
 - maintenance, service 148
 - manuals 1
 - margins
 - specification 220
 - Materials 40, 41
 - memory specifications 222
- N**
 - needles, clean 142
 - needles, replace 144
- O**
 - optimizer
 - about 94
- P**
 - physical specifications 222
 - power specifications 222
 - print jobs 91
 - print quality, improve 172
 - print-quality problems
 - black areas look hazy 186
 - bleeding 188
 - color variation 184, 185
 - general 171
 - graininess 177
 - horizontal banding 178
 - ink smears 186
 - ink smudges 188
 - misaligned colors 185
 - oily ink 188
 - text-line correction 184, 185
 - tiling 189
 - uneven area fill 188
 - vertical banding 183
 - vertical gloss banding 183
 - white-to-color
 - misalignment 190
 - wrong size 189

- printer 215
 - clean 146
 - move 216
 - store 219
- Printer
 - diagnostics 27
- printer accessories 210
- printer does not print 198
- printer does not restart 198
- printer does not start 198
- printer not detected 198
- printer on/off 18
- printer status 23
- printer's main components 10
- printer's main features 1
- printhead
 - align 126
 - alignment status plot 176
 - cannot insert 196
 - check and clean 132
 - cleaning connections 132
 - replace 98, 99, 102
 - reseal 196
 - ship 104
 - specification 220
 - status plot 175
 - store 104
- printhead (R530 series)
 - about 97
- printhead carriage rod
 - clean and lubricate 139
- printing speeds 220
- PrintOS 14

Q

- QR code 1

R

- R430 50
- R530 40, 41, 50
- rear view 11, 12
- replace ink collection unit 109
- restart the printer 20
- Rigid media 50
- RIP
 - adding jobs from 91

S

- safety labels 7
- service information print 3
- service maintenance 148
- slow printing 199

- specifications
 - acoustic 223
 - ecological 223
 - environmental 223
 - functional 220
 - hard disk 222
 - ink supplies 220
 - margins 220
 - memory 222
 - physical 222
 - power 222
 - printing speeds 220
- straightness optimization 159
- substrate 39
 - add preset 81
 - belt marks 166
 - bow deformation 159
 - cannot be measured 158
 - configuration 76
 - detached from core 156
 - dialog 77
 - flexible
 - recommendations 250
 - handling 42
 - ink marks 170
 - length tracking 76
 - load 55
 - load rigid 42, 43, 45
 - new 81
 - parameters 76
 - physical marks 166
 - Print from pinch for flexible
 - media 158
 - rigid recommendations 226
 - skewed 156, 169
 - storage 42
 - take-up reel 58
 - telescoping 156, 169
 - tips 74
 - too close to carriage 167
 - unload 62
 - vibration noise 169
 - wrinkles 167
- substrate presets 80
 - generic 80
 - online search 87
- Substrates 39
- support services
 - HP Customer Care 2
- system error codes 200

T

- take-up reel
 - using 58

- telephone number 3
- telephone support 2

W

- warning 7
- warning labels 7
- welcome to your printer 1
- white ink
 - about 115
 - best practices 123
 - job preparation 120
 - print modes 120
 - printhead storage system 117